

Comparative study of operation of condensing and traditional boilers equipped with the ORC module for electricity generation

Dariusz Mikielewicz^{1,*}, Jarosław Mikielewicz²

¹Gdańsk University of Technology, Faculty of Mechanical Engineering, ul. Narutowicza 11/12, 80-233 Gdańsk, Poland

²Institute of Fluid-Flow Machinery PAS, ul. Fiszerza 15, 80-231 Gdańsk, Poland

Abstract. Condensing technology applied to boilers is to make full use of thermal energy contained in the fuel. That means that additionally the heat from condensation of exhaust gases can be used for the purposes of heating the domestic hot water and to cover the demand for central heating. The study analyzed the operation of the "traditional" boiler equipped with the ORC module as the similar arrangement but with the condensing boiler. In the case of a conventional boiler there is noted a greater fuel consumption and the greater power generated than in the case of the unit with the condensing boiler. Postulated is the indicator in the form of a ratio of turbine power to the mass flow rate of fuel, which in turn gives a higher value for the condensing boiler, thus demonstrating that the operation of condensing boiler ORC module will be more economical. Perspective domestic micro CHP with ORC should be installed in boilers with recovery of heat from condensation from the exhaust gases.

1 Introduction

Condensing technology in boilers is to make a full use of thermal energy contained in the fuel. A full utilisation of thermal energy means that the energy contained in the water moisture in exhaust gases can be recovered by means of condensation. That is obtained by cooling of the exhaust gases so that the moisture undergoes condensation removing heat to the heated water.

In condensing boilers mostly the natural gas is used characteristic for the fact that it contains some hydrogen and hence the significant amount of moisture is produced in the combustion process. Similar situation holds in the case of the thermal oil.

The normalised thermal efficiency of the condensing boiler is usually reaching 105÷109 %. That stems from the assumptions to the standards which did not foresee the possibility of heat recovery from the moisture in exhaust gases. The moisture contained in the exhaust gases of traditional boilers is directed to the chimney without moisture condensation. Hence the reference value (100%) was assumed as the energy contained in the dry exhaust gases E_{OUT} and it was that value to which the efficiency was referring:

$$\eta = \frac{E_{OUT}}{E_{IN}(=100\%)} \quad (1)$$

In that definition the heat contained in the moisture was totally neglected and the attainable efficiencies smaller than about 90%. Due to the fact that the standard related to determination of the boiler efficiency has not changed over the time and the fact that for some time

there are on the market the condensing boilers enabling condensation of the moisture from exhaust gases, hence recovering that heat, the output energy E_{OUT} is supplemented with additional component E_{H_2O} obtained from moisture condensation from exhaust gases:

$$\eta = \frac{E_{OUT} + E_{H_2O}}{E_{IN}(=100\%)} \quad (2)$$

In such case the nominator can attain higher values than the denominator due to the fact that efficiencies of the boilers are higher than 90% and additional component resulting from the condensation of moisture contributes with extra 10% of energy. In effect the efficiencies exceeding 100% are obtained, namely of the order 105-107%. Due to application of such condensing boilers for heating purposes obtained are attractive economical benefits. An increased boiler efficiency converts to the reduction of annual demand for gaseous fuel and hence the reduction in heating costs.

The moisture content in exhaust gases confirms that contained there is energy which, if not managed, is lost to the chimney. The exhaust gases leaving the traditional boiler have a temperature reaching even 200°C. One of the components of the boiler is the heat receiver known as the exhaust gases/water heat exchanger. Its task is to receive heat from the exhaust gases and subsequently to transfer it to water. In the condensing boiler the heat exchanger is very different than in traditional boilers. First of all it is designed in such a way that it can cool exhaust gases below the dew point temperature, rendering in such a way condensation of moisture, which it related to the transfer of heat to cooling water. That

* Corresponding author: Dariusz.Mikielewicz@pg.gda.pl

process is relatively simple but requires application of adequate materials, which on other hand are rather expensive. It may happen that moisture has an acidic indicator with pH at the level of 4-5. Due to that fact the material of the tubes used for that purpose in condensing boilers should withstand and resist the action of acid condensate. By application of acid resistant steels and special cast alloys it is possible to recover a significant amount of heat from the exhaust gases. Appropriate selection of the material does not lead to material damages of other equipment. The amount of produced condensate depends primarily on the size of boiler as well as the operational conditions. The condensation process occurs when the exhaust gases will be cooled below specified low temperature, which must be preceded by reduction of temperature of water. Under normal conditions the condensation occurs at temperature of exhaust gases of about 50°C. Every condensing boiler is additionally equipped with the system for removing of the excess of condensate.

2 The boiler model cooperating with the micro CHP ORC module

The concept of the cogenerative boiler of the so called IIIrd generation is under development at the Department of Energy and Industrial Apparatus for some time now, Fig. 1. Such domestic microCHP, cooperating with the ORC module is scheduled to produce heat. Electricity is generated as a byproduct, when there is the demand for heat. In Authors opinion the considered cogenerative boiler will replace the traditional and condensing boilers in the future for providing heat to single-family houses, multi-family houses or even entire etates, [1]. As far as the size is concerned the boiler with the ORC module will only be bigger a little, not more than one third of the original size. However, apart from the heating function it will additionally generate electricity. The cogenerative boiler will operate in significantly lower temperatures than the combustion engine or the gas turbine. Hence it will require less of expensive materials and the technology of manufacturing is simpler. With its help it is possible to generate electricity with the price comparable to electricity produced in professional power plants of large power. Better utilisation of fuel energy in cogenerative boilers leads to reduction of emissions accompanying the fuel combustion process. The small cogenerative boiler can be fully automated and does not require support. The basic elements of the cogenerative boiler are: boiler (evaporator), vapour turbine, condenser, electricity generator and the circulation pump.

The concept of the cogenerative boiler requires solving of new problems such as the selection of optimal thermodynamic cycle [2,3], selection of the adequate working fluid [4,5], development of relevant calculation algorithms of heat exchangers (evaporator, condenser and in some cases regenerator) and the thermodynamic cycle for the cogenerative system [6,7]. Interesting is also the performance of the gas boiler cooperating with

the ORC or whether in the latter case it would be possible to condense moisture from the exhaust gases.

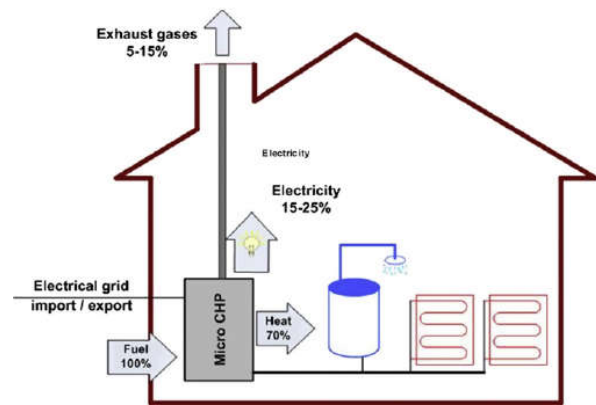

Fig. 1. Schematic of cogenerative boiler.

Integrated calculation model of the boiler and the ORC module has been developed to a simple cogenerative system with internal regeneration, has been schematically presented in Fig. 2.

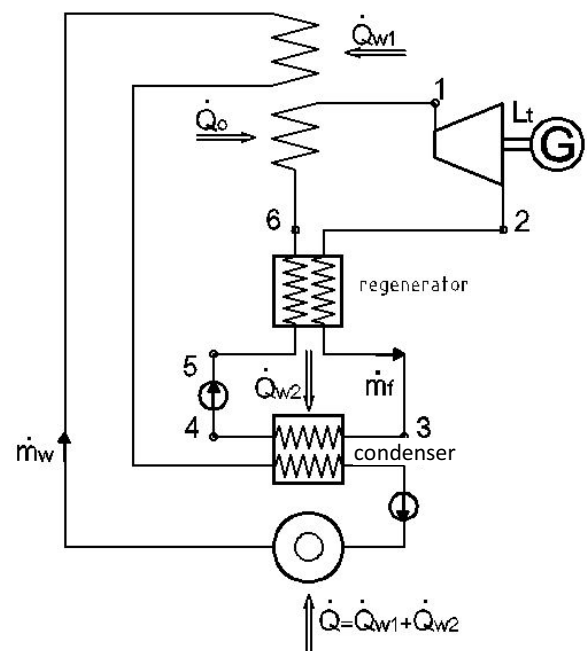

Fig. 2. Scheme of cogenerative boiler with intermediate heating.

In the present paper it has been assumed that the heat losses in the case of traditional boiler are about 10%, whereas in the case of condensing boiler these can be assumed as negligibly small, hence for the study these were assumed as 0%. Considered in the paper turbine power are not including circulation pump of ORC. In case of the fluid considered here it is negligible. Also not considered in the analysis are circulation pumps of the central heating and domestic hot water circuits, as such pumps are present in the case of the boiler with and without the ORC. They are of comparable capacities.

2.1 Traditional boiler with ORC module without moisture condensation

In the paper it has been assumed, that the demand for central heating and domestic hot water is equal to $\dot{Q} = \dot{Q}_{w1} + \dot{Q}_{w2} = 20\text{kW}$. The boiler is supplied with chemical energy in the form of the rate of heat resulting from combustion of gaseous fuel with the flow rate $\dot{m}_{p,1}$ of specified low calorific value W_p :

$$\dot{Q}_{0,1} = \dot{m}_{p,1} W_p \quad (3)$$

The heat is used for production of work in the expansion device as well as for heating of water in the condenser which is next directed to the heat receivers. In the case of the boiler without condensation of moisture from the exhaust gases the heat produced in the boiler is removed from the condenser in the amount $\dot{Q}_{w2,1}$ (scheduled for covering the demand for central heating and domestic hot water), as well as in the form of work produced in the turbine, $\dot{L}_{t,1}$. No condensation of moisture from the exhaust gases is considered at the moment, i.e. $\dot{Q}_{w1,1} = 0$. There is also some loss of energy through the chimney, which is related to higher than the dew point temperature. The energy balance yields :

$$\dot{Q}_{0,1} = \dot{m}_{p,1} W_p = \dot{Q}_{w1,1} + \dot{Q}_{w2,1} + \dot{L}_{t,1} + \dot{Q}_{stack1} \quad (4)$$

The work which is obtained in the turbine is determined from the knowledge of enthalpy before and after the turbine and the mass flow rate of ORC working fluid:

$$\dot{L}_{t,1} = \dot{m}_{f,1} (h_1 - h_2) \quad (5)$$

In the case of traditional boiler the amount of working fluid circulating in the ORC installation is determined from the condenser balance, where the demand for heat is known and equal to the total heat demand for central heating and hot water ($\dot{Q} = \dot{Q}_{w2,1} = 20\text{kW}$) :

$$\dot{Q} = \dot{Q}_{w2,1} = \dot{m}_{f,1} (h_2 - h_4) \quad (6)$$

Taking into consideration the simplifying assumption that the heat transferred through the chimney is about 10% of supplied heat to the boiler we can determine the mass flow rate of the fuel required to cover heat demand:

$$\dot{m}_{p,1} = \frac{\dot{Q} + \dot{L}_{t,1}}{0.9 W_p} \quad (7)$$

The thermodynamic efficiency of the cycle yields:

$$\eta_h = \frac{\dot{Q} + \dot{L}_{t,1}}{\dot{m}_{p,1} W_p} \quad (8)$$

At the assumptions set in the present work the total efficiency is 0.9 (other losses are neglected).

2.2 Traditional boiler with ORC module with moisture condensation

In the case when we are dealing with condensation of moisture from the exhaust gases we supply to the condenser a smaller rate of heat, as part of utility hot water will receive the heat from condensation of moisture in the exhaust gases. Smaller amount of heat supplied to the evaporator of ORC will render a reduced production of electricity in ORC in comparison to the traditional boiler as a smaller mass flow rate of working fluid will circulate. Presence of the regenerator in the system causes that the central heating and hot water systems are supplied only due to the heat of phase change in the condenser, h_{lv} . That influences the mass flow rate of working fluid in ORC installation. The reduced heat demand in the condenser is due to the fact that part of heat demand is covered by heat of condensation of moisture from the exhaust gases, $\dot{Q}_{w1,2}$. In the considered case the return water from central heating installation can be heated and respectively less heat will be required to be supplied to condenser:

$$\dot{Q}_{0,2} = \dot{m}_{p,2} W_p = \dot{Q}_{w1,2} + \dot{L}_{t,2} + \dot{Q}_{w2,2} + \dot{Q}_{stack2} = \dot{Q} + \dot{L}_{t,2} + \dot{Q}_{stack2} \quad (9)$$

In that case the heat in the form of the mass flow rate of exhaust gases is removed to atmosphere having a small enthalpy, as it is assumed that the exhaust gases will feature temperature smaller than 50°C and the condensation of moisture will be present. Hence it can be assumed that heat removed to the chimney will be equal zero, $\dot{Q}_{stack2} = 0$.

In such case the mass flow rate of fuel required to supply the rate of heat to the cycle will be lower than in the case without condensation. It will yield:

$$\dot{m}_{p,2} = \frac{\dot{Q}_{w1,2} + \dot{Q}_{w2,2} + \dot{L}_{t,2}}{W_p} = \frac{\dot{Q} + \dot{L}_{t,2}}{W_p} \quad (10)$$

In such case the turbine power will yield:

$$\dot{L}_{t,2} = \dot{m}_{f,2} (h_1 - h_2) \quad (11)$$

Amount of working fluid circulating in the installation will also be determined from the energy balance of condenser. In such case it is assumed however that only 90% of heat will be supplied to the condenser:

$$\dot{Q}_{w2,2} = 0.9 \dot{Q} = \dot{m}_{f,2} h_{lv} \quad (12)$$

Additionally in the present analysis it has been assumed that ORC is realised in the same temperatures as in the case without condensation and therefore the enthalpy drop in the expansion device will be the same.

The total efficiency in the case of heat recovery is determined from the relation:

$$\eta_2 = \frac{\dot{Q}_{w1,2} + \dot{Q}_{w2,2} + \dot{L}_{t,2}}{\dot{m}_{p,2} W_p} = \frac{\dot{Q} + \dot{L}_{t,2}}{\dot{m}_{p,2} W_p} \quad (13)$$

In line with the assumptions other heat losses have been neglected in the analysis. In case of condensing boiler cooperating with the ORC the heat transferred to the central heating installation consists of two components. The first one is the heat removed from the condenser ($\dot{Q}_{w,2,2}=0.9\dot{Q}$) and the rest of heat, which results from the condensation of moisture from exhaust gases. In the analysis it has been assumed that $\dot{Q}_{w,1,2}=0.1\dot{Q}$.

3 Results of calculations

In order to show the performance of the two cases an appropriate algorithm has been developed and calculations were carried out in the MathCAD15 environment. It has been assumed that the temperature of vapour before turbine is $t_1=160^\circ\text{C}$, whereas temperature of condensation is 50°C . Rate of heat in the amount $\dot{Q}=20\text{kW}$ is given away to the central heating and domestic hot water installation. In the case of traditional boiler that heat is entirely generated in the ORC and is removed in the condenser to the heat receivers. In the case of condensing boiler in the condenser the rate of heat $\dot{Q}_{w,2,2}=0.9\dot{Q}$ is transferred, as the remainder is supplied to the central heating installation with the heat due to condensation of moisture from exhaust gases. That heat has been estimated to be equal to ten percent of the total heat demand, $\dot{Q}_{w,1,2}=0.1\dot{Q}$. It should be remembered that in case of dry fluids in ORC installation there is the regenerator in the system, in which vapour after expansion is cooled to the saturation temperature. The liquid subcooling is not considered.

Table 1. Results of calculation for the traditional boiler (only the heat of phase change is considered h_{lv}).

Fluid	$\dot{m}_{p,1}$ kg/s $\times 10^{-3}$	$\dot{m}_{r,1}$ kg/s	$\dot{L}_{i,1}$ kW	$\dot{Q}_{0,1}$ kW	$\dot{L}_{p,1}$ kW	$\eta_{\text{ORC } 1}$	$\dot{L}_{i,1}/\dot{m}_{p,1}$ [J/kg] $\times 10^{-6}$
R123	0.853	0.125	6.421	29.36	0.204	0.219	7.531
D4	1.167	0.113	16.16	40.18	0.008	0.402	13.85
MDM	1.220	0.103	17.79	41.99	0.015	0.424	14.59
HFE7100	1.165	0.175	16.46	32.90		0.175	14.13
Etanol	0.807	0.022	5.018	27.80	0.035	0.181	6.215

Table 2. Results of calculation for the condensing boiler (only the heat of phase change is considered h_{lv}).

Fluid	$\dot{m}_{p,2}$ kg/s $\times 10^{-2}$	$\dot{m}_{r,2}$ kg/s	$\dot{L}_{i,2}$ kW	$\dot{Q}_{0,2}$ kW	$\dot{L}_{p,1}$ kW	$\eta_{\text{ORC } 2}$	$\dot{L}_{i,2}/\dot{m}_{p,2}$ J/kg $\times 10^{-6}$
R123	0.749	0.112	5.779	25.78	0.183	0.229	7.718
D4	1.003	0.101	14.54	34.54	0.007	0.421	14.50
MDM	1.046	0.092	16.01	36.01	0.014	0.424	15.31
HFE7100	1.011	0.157	14.81	28.65		0.410	14.65
Etanol	0.712	0.020	4.516	24.52	0.032	0.184	6.343

It has been assumed that the system is supplied with a high methane content natural gas GZ-50 with a low calorific value of 34430 kJ/m^3 . Considered have been 5 working fluids, ie. R123, ethanol, D4, MDM and HFE7100. The physical data for first four fluids have been taken from fluid data base Refprop9.0 [8]. The data for HFE7100 have been taken from the data base in

Engineering Equation Solver EES [9]. Selected fluids are the most probable to be implemented in the ORC installation, which can be commercialised. The results of the calculations have been presented in Table 1 for the case of traditional boiler and in Table 2 for the condensing boiler.

4 Conclusions

A special indicator, formulated as the ratio of turbine power to the mass flow rate of fuel has been postulated in the analysis. The value of the indicator has been evaluated both for the case of the traditional boiler with the ORC module and the condensing boiler equipped with the ORC module. In the case of traditional boiler the greater consumption of fuel is noticed as well as a higher level of electricity generation than in the case of the condensing boiler. The developed indicator returns higher values for the case of the condensing boiler showing that the operation of condensing boiler with the ORC module should be more economical.

In the case of condensing boiler still open is the case how the moisture condensation can be made. For the assumptions made in the paper it seems that moisture condensation can only be possible in case of the low-temperature heating installation.

The cogenerative boiler of the third generation featuring the electricity generating module should be installed in units featuring the heat recovery in the form of condensing the moisture from exhaust gases.

References

1. D. Mikielewicz, J. Mikielewicz, Cogenerative micro power plants – a new direction for development of power engineering? Archives of Thermodynamics, 29(4), 2008, 109-132.
2. J. Mikielewicz, D. Mikielewicz, A thermodynamic criterion for selection of working fluid for subcritical and supercritical domestic micro CHP, Applied Thermal Eng., Vol. 30, 2010, 2357-2362.
3. D. Mikielewicz, J. Wajs, J. Mikielewicz, Gas boiler as a heat source for the domestic micro-CHP, J. of Power Technologies, vol. 94(4), 2014, 317 - 322.
4. J. Mikielewicz, D. Mikielewicz, Comparative study of selected fluids for use in supercritical ORC. Arch. of Thermodynamics, Vol. 30(2), 2009, 3-14.
5. J. Mikielewicz, D. Mikielewicz, Optimal boiling temperature for ORC installation, Archives of Thermodynamics, Vol. 33(3), 2012, 27-37.
6. D. Mikielewicz, J. Mikielewicz, E. Ihnatowicz, T. Muszyński, J. Wajs, W. Rybiński, Selected aspects of designing and testing of heat exchangers for ORC in the domestic microCHP, IMP PAN, 2013 (in PL).
7. J. Mikielewicz, D. Mikielewicz, Thermal-hydraulic issues of flow boiling and condensation in organic Rankine cycle heat exchangers, Archives of Thermodynamics, vol. 33(1), 2012, 41-66.
8. Refprop 9.0. National Institute of Standards, 2010.
9. Engineering Equation Solver (EES) website F-Chart Software <http://www.fchart.com>.