

Analysis of a combined heating and cooling system model under different operating strategies

*Mieczysław Dzierzgowski*¹, and *Ryszard Zwierzchowski*^{1,*}

¹Department of Heating and Gas Engineering, Faculty of Building Services, Hydro and Environmental Engineering, Warsaw University of Technology, ul. Nowowiejska 20, 00-653 Warsaw, Poland

Abstract. The paper presents an analysis of a combined heating and cooling system model under different operating strategies. Cooling demand for air conditioning purposes has grown steadily in Poland since the early 1990s. The main clients are large office buildings and shopping malls in downtown locations. Increased demand for heat in the summer would mitigate a number of problems regarding District Heating System (DHS) operation at minimum power, affecting the average annual price of heat (in summertime the share of costs related to transport losses is a strong cost factor). In the paper, computer simulations were performed for different supply network water temperature, assuming as input, real changes in the parameters of the DHS (heat demand, flow rates, etc.). On the basis of calculations and taking into account investment costs of the Absorption Refrigeration System (ARS) and the Thermal Energy Storage (TES) system, an optimal capacity of the TES system was proposed to ensure smooth and efficient operation of the District Heating Plant (DHP). Application of ARS with the TES system in the DHS in question increases net profit by 19.4%, reducing the cooling price for consumers by 40%.

1 Introduction

Cooling demand for Air Conditioning (AC) purposes has grown steadily in Poland since the early 1990s. The main clients are large office buildings and shopping malls located in city centers. In widespread conventional cooling systems, demand for air conditioning is met by centrally installed compressor chillers in Compressor Refrigeration System (CRS) producing chilled water streamed to receivers – fancoils or coolers in air handling units, using a dedicated hydraulic installation inside the building. Electricity is the driving medium for producing chilled water in CRS. There is an increasing scarcity and cost associated with the medium, especially in light of recent summertime blackouts in Poland. There is a steady increase in the demand for electricity in the summer and in the price for cooling capacity for the end user [1]. Both factors have an adverse impact on large office buildings, shopping malls, sports and culture centers in cities as main customers for

* Corresponding author: ryszard.zwierzchowski@is.pw.edu.pl

cooling, and on the attractiveness of cooling supply generated from heat using absorption chillers in the Absorption Refrigeration System (ARS) [2–5].

2 System description

The District Heating System (DHS) subject to analysis supplies heat to a town of 20,000 inhabitants in central Poland. The DHS consists of a District Heating Plant (DHP) with total power of around 7 MW, District Heating Network (DHN) with total length of 3.1 km and 39 District Heating Substations (DHSu). The layout of the DHS is shown in Fig. 1.

The DHP consists of 5 heat only boilers, 3 of them with heating power of 1750 kW each are connected in a cascade scheme and operate during the heating season, while the other 2 with heating power of 970 kW each are designated to operate during the summer season. All boilers are Condensing type Boilers (CB). The DHN supply heat to consumers connected to the system through 39 indirect, 2-function DHSu, i.e., supply heat for Central Heating (CH) and Domestic Hot Water (DHW) purposes. The main piping of the DHN features nominal diameters 200 and 150 mm, others are 25–100 mm, all of them pre-insulating piping.

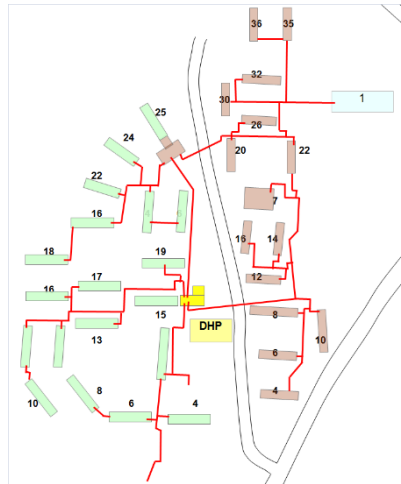

Fig. 1. Layout of present state of analyzed DHS.

The current total heat demand of consumers is 5.0 MW and by category: 4.0 MW for CH and 1.0 MW for DHW purposes, but the real total heat demand is 3.4 MW (2.6 MW for CH and 0.8 MW for DHW). During the last three years, the annual amount of heat sold to consumers is 31 000 GJ and heat transportation losses are 10–11.5%, but during the summer season losses reach 25%. The quantity of degree-days in that period is in the range 3684.4–3981.0. Pressure disposal in the DHP varies in the range 180–220 kPa (average is 188 kPa), while water supply and return temperatures are in the range 70–94.1°C (average is 71.6°C), and 40–64.1°C (average is 46.5°C) respectively. The real value of total flow coefficient K_v of the DHN varies from 19.6 to 127.4 m³/h (average is 47.4 m³/h) and the drop in water temperature in the DHN is 11.8–31.5 K (average is 23°C).

Analyses of operational data have indicated that currently there is insufficient adaptation of operation conditions of the DHP to real consumer demand for heat for CH purposes. The biggest value of this discrepancy, which is characterized through the

Coefficient of Heat Load (CHL), is below 0.43 and appears in the transition period with the outside temperature of +3°C, which is most of the time of the heating season.

Figure 2 shows in schematic form the DHS with the Thermal Energy Storage (TES), which produces and distributes heat for both heating and cooling purposes. In the analyzed case, heat is produced in in the DHP furnished with 5 CB for CH and DHW purposes during the heating season, and chilled water for Air Conditioning (AC) and DHW during the summer season.

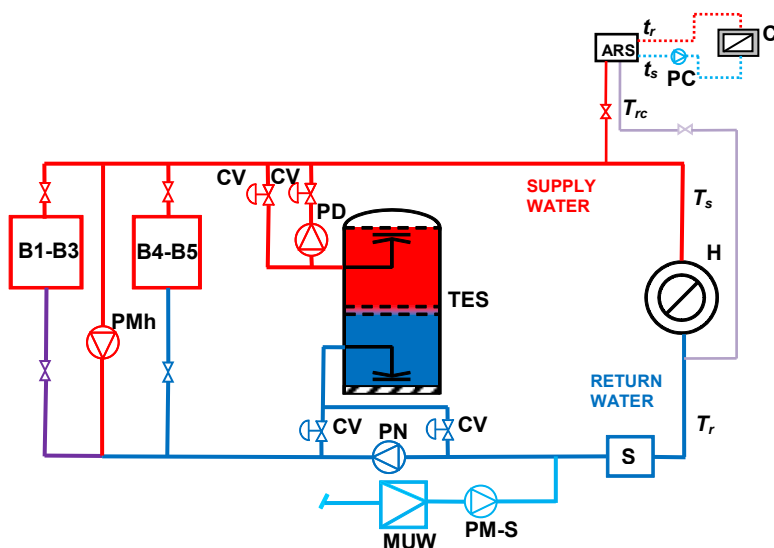

Fig. 2. Schematic layout of the DHS with TES which supplies heat for CH, DHW and AC purposes. Descriptions of symbols: B - boiler, C – cold consumers, CV – control valve, H – heat consumers, MUW – make-up water station, PC – chilled water pumps, PD – TES pump, PMh – hot water mixing pumps, PM-S - make-up water and pressure stabilizing pumps, PN – network pumps, S – sludger.

3 Absorption Chillers

3.1 Application of ARS for DHS

In Poland, most DHS supply only heat to their clients, but during the summer season heat demand falls significantly in most urban areas which, taking into consideration the significantly lower price growth rate of heat in comparison e.g. to the electricity price growth rate, defines the potential use of DHS during the summer to power ARS [6].

Also benefiting from increasing heating demand in summer would be CHP plants, as they could boost electricity production due to the increased heat demand.

3.1 Calculation of hot water flow rate for supplying ARS

To give an idea of increased heat demand, an example is given below of the calculation of hot water flow increase for the purposes of supplying ARS with various cooling capacities from 500 kW to 1000 kW. For the purposes of the calculation some assumptions regarding the absorption chillers Coefficient of Performance (COP) were made [7, 8].

$$\dot{m}_{ARS} = \dot{Q}_{ARS} / (COP \cdot \Delta T \cdot C_w) \tag{1}$$

where: $\Delta T = T_s - T_{rc}$

The above formula makes it possible to calculate the supply water mass flow needed to produce 100% cooling capacity. For example, for 500 kW of cooling capacity we need 38.99 Mg/h of hot water at 85°C/70°C, 750 kW needs 58.48 Mg/h and 1000 kW needs 77.97 Mg/h, taking into consideration an average COP of 0.735 for the ARS.

To give greater insight, example calculations have been made using the following formula:

$$CF = \dot{m}_{ARS(r)} / \dot{Q}_{ARS(r)d} \quad (2)$$

The *CF* is applied to gain the hot water mass flow.

$$\dot{m}_{ARS}^{CF} = \dot{m}_{ARS} \cdot CF \quad (3)$$

4 Operational analyses of DHS due to introduction of cooling generation

A detailed analysis of this tri-generation system was performed. The analysis covers the effect of increase in supply temperature, both on efficiencies of heat generation in CB and chilled water production in ARS. Also, changes in water flowrate, return temperature and pressure disposal were analyzed for water supply temperatures in the range 70°C to 85°C.

Efficiency of heat generation in condensing type gas boilers was approximated on the basis of real experimental data through polynomial in the following form:

$$\eta_b = a_6 \cdot T_{av}^6 + a_5 \cdot T_{av}^5 + a_4 \cdot T_{av}^4 + a_3 \cdot T_{av}^3 + a_2 \cdot T_{av}^2 + a_1 T_{av} + a_0 \quad (4)$$

where: $T_{av} = (T_s - T_r) / 2$

Useable power of DHP was calculated from the equation:

$$\dot{Q}_{DHP} = \dot{V}_g \cdot W_u \cdot \eta_b \quad (5)$$

Heating power balance for the system could be expressed in the following way:

$$\dot{Q}_{DHP} = \dot{Q}_L^{sp} + \dot{Q}_{DHW} + \dot{Q}_{ARS} + \dot{Q}_L^{rp} \quad (6)$$

Required power to generate DHW could be calculated as:

$$\dot{Q}_{DHW} = \dot{m}_{DHW} \cdot (T_s - T_r) \cdot C_w \quad (7)$$

Losses of power from supply DHN were calculated from the equation:

$$\dot{Q}_L^{sp} = (T_s - t_e) / R_{rp-te} \quad (8)$$

Losses of power from return DHN are the following:

$$\dot{Q}_L^{rp} = (T_r - t_e) \cdot R_{rp-te} \quad (9)$$

Required heating power of ARS was estimated by heat effects in cooling spaces:

$$\dot{Q}_{ARS} = \dot{Q}_{ee} + \dot{Q}_{el} + \dot{Q}_{em} + \dot{Q}_{ent} + \dot{Q}_{ep} + \dot{Q}_{et} \quad (10)$$

4.1 Analysis of increase in supply water temperature

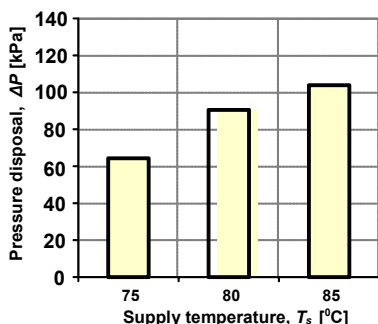

Fig. 3. Influence of supply temperature T_s on required pressure disposal ΔP for DHS.

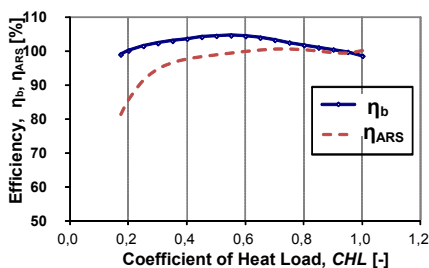

Fig. 4. Influence of CHL on efficiency of heat and cool generation.

As a result of increase in supply water temperature T_s for DHS, increase in heat losses from supply piping is evident. Simultaneously, the following can be observed: decrease in required pressure disposal for DHS and in flow rate of water supplying DHSu (Fig. 3). Simultaneously, the working conditions and effectiveness of chilled water production by absorption chillers are improved [9–11]. Fig. 4 presents changes in efficiency of heat generation in the CB and cool generation in absorption chillers vs. Coefficient of Heat Load (CHL).

4.2 Analysis of heat supply for chilled water production purposes

Seasonal, simulation calculations of heat demand for chilled water production by absorption chillers were carried out for habitable-office building.

Fig. 5 shows changes in flowrate of water and heat demand for DHW and chilled water for the analyzed building on 8 selected days in May.

4.3 Operation of TES and its influence on DHS

Operational analyses of the DHS were performed for the purpose of selecting the appropriate size of the TES in order to increase the operational efficiency of the existing

CB especially for DHW and ARS. Investment costs for the ARS and the TES system application in the DHS were also assessed [12].

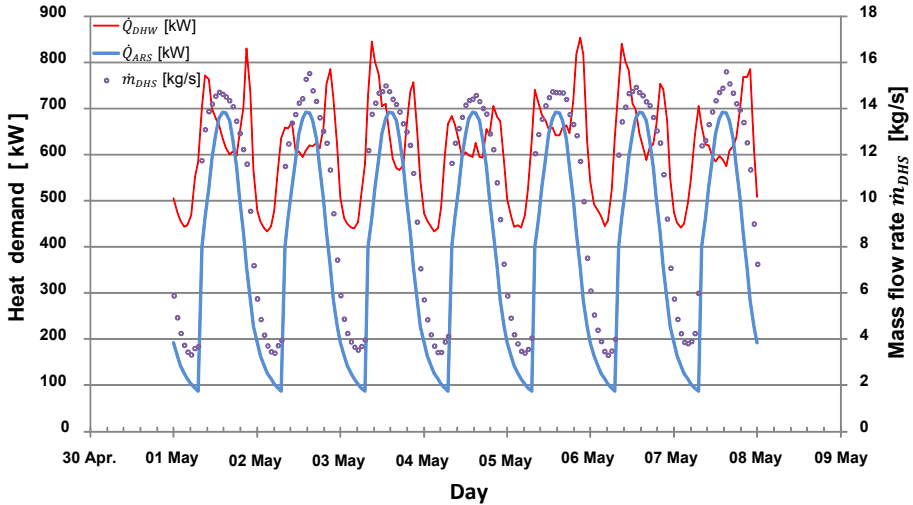

Fig. 5. Hourly changes in heat demand for chilled water production, cool demand and total flowrate of network water for the analyzed building and eight selected days in May.

Operational analysis of the DHS covered supply and demand side, i.e., heat generation by the CB and heat consumption by existing consumers for DHW purposes and new consumers for ARS purposes. Heat consumption analysis for the summer season was carried out in order to increase operational efficiency of the ARS installation and to investigate the application of TES systems in the DHS. Heat storage in the DHS and its effect on power and operation of the CB was investigated i.e., heat accumulation by (i) the DHN, and (ii) the non-pressure TES system was analyzed [13].

Finally, the calculation results were shown for the required capacity of the TES systems assuring continuous and efficient operation of the CB installation in the DHS, especially during the summer season. Also presented were some advantages of implementing the TES system in the DHS in the case where the CB and ARS are applied. Simulation of the DHS with the TES system using real, operational data for the system situated in central-southern Poland (real total heat demand is 3.4 MW i.e. 2.6 MW for CH and 0.8 MW for DHW) was performed to determine the optimum capacity of the TES tank from an operational point of view. The optimum capacity of the TES tank from an operational point of view means that the boilers can operate for a long time practically at constant capacity. The DHS heat demand fluctuation can be covered by the TES system. For the optimum operating conditions of the CB the volume of the TES system is approx. $V_{TES} = 55 \text{ m}^3$. Changes in heating capacity of the CB and heat demand by the DHS during 2 weeks' operation in the summer season for boilers with total capacity of 970 kW are shown in Fig. 6.

Changes in the charging and discharging processes of the TES system for optimum operational heating capacity of the CB were analyzed. Fig. 6 shows also changes in the charging and discharging processes of the TES taking into consideration the capacity of the DHN, during 2 weeks' operation in the summer season for optimum boiler power.

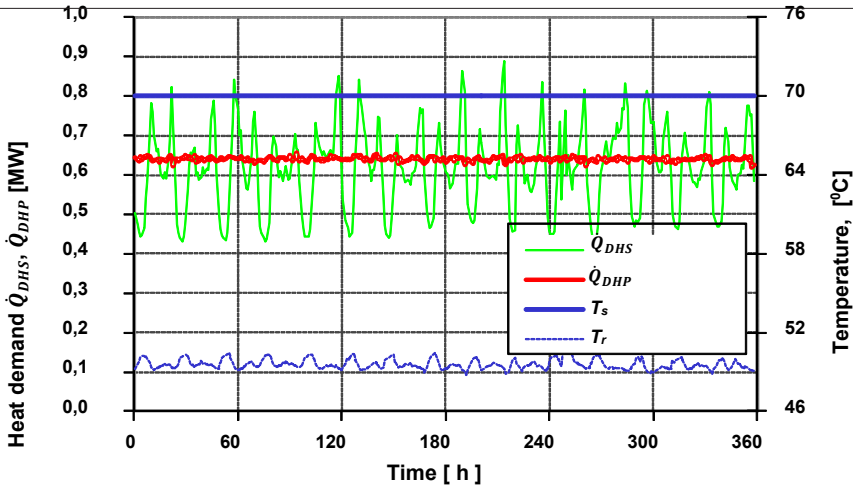

Fig. 6. Changes in boiler power, DHS heat demand, T_s and T_r with the TES application during 2 weeks in the summer.

5 Influence of cooling generation on conditions of DHS

Results of detailed analysis show that additional heat production for chilled water purposes has a major effect on technological and economical operation of the existing system, especially in the summer season. The required condition to increase water supply temperature T_s , causes increased total heat losses of the DHN, slightly decreased efficiency of heat production by the CB and increased fuel consumption. Influence of cooling generation on operational and economic conditions of DHS is shown in Fig. 7. Moreover, existing infrastructure and flow capacity of DHN will be much better utilized when additional heat production for chilled water starts, e.g., total heat losses of DHN will drop from the current 25% to 19%. Taking into consideration the present condition of heat generation for DHW purposes in the summer season, when the supply temperature of network water T_s is 70°C, and the new condition when T_s is raised to 85°C due to chilled water production, the following items shown in Table 1 will change.

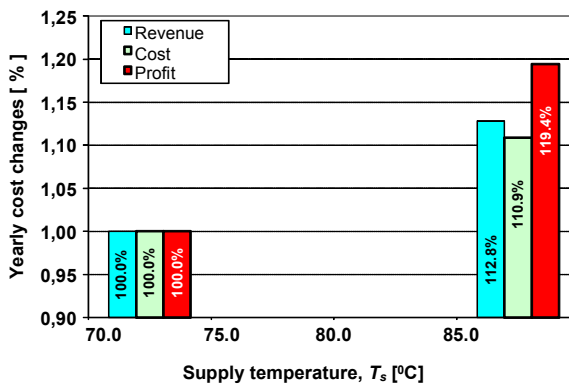

Fig. 7. Changes in costs, revenue and profit after ARS application.

Table 1. Influence of cooling generation on conditions of DHS.

Increase in [%]	fuel costs	pumping costs	heat losses costs	operating costs	total costs	total revenue	profit
	3.5	46.6	35.3	10.9	27.7	12.8	19.4

6 Conclusions

In this paper, computer simulations were performed for different supply temperature T_s in DHN, assuming as input, real changes in the basic parameters of the DHS (heat demand for DHW and ARS, flow rates, pressure disposal). On the basis of the above-mentioned calculations and taking into account investment costs of the ARS and the TES system, an optimal size (capacity) of the TES system was proposed for the considered DHS.

Finally, the capacity of the TES system was 55 m³ ensuring smooth and efficient operation of the CB. Application of the ARS with the TES system in the DHS in question increases net profit by 19.4%, reducing the cooling price for consumers by 40% – from 0.60 PLN/kWh to 0.35 PLN/kWh. The existing CB can operate with high constant efficiency in the wide range of changes in DHS heat demand.

Expected advantages of applying the ARS and TES system in the DHS are as follows:

- increase in overall, operational efficiency of heat generation, by operation of the CB close to optimal conditions of the units,
- decrease in fuel consumption due to continuous operation of the CB with capacity within the limits of high efficiency,
- decrease in the emission of pollutants to the atmospheric air,
- smooth and continuous operation of the CB, which leads to higher availability of the unit and increased failure-free operation time,
- decrease in the percentage of heat losses from DHS, especially during the summer season (from 19% to 25%),
- decrease in the percentage of water losses in the DHS related to water expansion with temperatures changes (the TES can additionally play the role of an expansion tank).

Nomenclature

Symbol	Description	Symbol	Description
a_0-a_6	constants (-)	\dot{Q}_L	power of heat losses of DHN (kW)
C_w	specific heat (kJ/(kg K))	\dot{Q}_L^{rp}	power of heat losses of ret. pipe (kW)
K_v	Flow Coefficient (m ³ /h)	\dot{Q}_L^{sp}	power of heat losses of sup. pipe (kW)
\dot{m}_{ARS}	water mass flow rate for ARS (kg/s)	R_{rp-te}	thermal resistant of return piping to external air(K/kW)
\dot{m}_{ARS}^{CF}	water mass flow rate considering CF (kg/s)	R_{sp-te}	thermal resistant of supply piping to external air(K/kW)
$\dot{m}_{ARS(r)}$	relative mass flow rate for ARS (%)	t_e	external air (ambient) temperature (°C)
\dot{m}_{DHS}	DHS mass flow rate (kg/s)	t_r	return chilled water temperature (°C)
\dot{m}_{DHW}	DHW mass flow rate (kg/s)	t_s	supply chilled water temperature (°C)
\dot{Q}_{ARS}	cooling power (kW)	T_{av}	average water temp. in DHN (°C)
$\dot{Q}_{ARS(r)d}$	relative cooling power demand (%)	T_r	return water temperature in DHN (°C)
\dot{Q}_{DHP}	heating power of DHP (kW)	T_{rc}	return water temp. from ARS (°C)
\dot{Q}_{DHS}	heating power of DHS (kW)	T_s	supply water temperature in DHN (°C)
\dot{Q}_{DHW}	heating power required for DHW production (kW)	\dot{V}_g	volumetric natural gas flow rate (m ³ /s)
\dot{Q}_{ee}	power of heat effects from electrical equipment (kW)	V_{TES}	volume of the TES (m ³)
\dot{Q}_{el}	power of heat effects from lighting (kW)	W_u	fuel net calorific value (kJ/nm ³)
\dot{Q}_{em}	power of heat effects from moisture (kW)	ΔP	pressure disposal (difference) (kPa)
\dot{Q}_{ent}	power of heat effects by non-transparent walls (kW)	ΔT	temperature difference (°C or K)
\dot{Q}_{ep}	power of heat effects by people (kW)	η_{ARS}	operational efficiency of ARS (%)
\dot{Q}_{et}	power of heat effects by transparent walls (kW)	η_b	operational efficiency of CB (%)

References

1. R. Zwierzchowski, M. Dzierzowski, Proceedings of the ASME **40**, 365–371 (2000)
2. E. Cardona, A. Piacentino, F. Cardona, Appl. Therm. Eng. **26**, 1427 (2006)
3. P. Chicco, P. Mancarella, Renew. Sustain. Energy Rev. **13**, 535 (2009)
4. M.A. Lozano, M. Carvalho, L.M. Serra, Energy **34**, 2001 (2009)
5. M.A. Lozano, J.C. Ramos, L.M. Serra, Energy **35**, 794 (2010)
6. K. Kavvadias, A.P. Tosios, Z. Maroulis, Energy Convers. Manag. **51**, 833 (2010)
7. P.W. Gerland, R.W. Gerland, Absorption Chillers: Technology for the Future, Energy Engineering **94**, 6 (1997)
8. O. Kaynakli, M. Kilic, Energy Convers. Manag. **48**, 599 (2007)
9. A. Smith, R. Luck, P.J. Mago, Energy Build. **42**, 2231 (2010)
10. P.J. Mago, L.M. Chamra, Energy Build. **41**, 1099 (2009)
11. S.M. Mohammadi, M. Ameri, Energy Build. **67**, 453 (2013)
12. I. Dincer, M.A. Rosen, *Thermal Energy Storage. Systems and Applications, Second Edition* (John Wiley & Sons, Ltd., Chichester, England, 2011)
13. R. Zwierzchowski, *The International Conference on Energy Efficiency and Control of Air Pollutants from Utilization of Fossil Fuels* (Wroclaw, Poland, 181, 2009)