

# Analysis and Assessment of Operation Risk for Hybrid AC/DC Power System based on the Monte Carlo Method

Xiaojing Hu<sup>1,\*</sup>, Qiang Li<sup>1</sup>, Hao Zhang<sup>2</sup>, Ziming Guo<sup>2</sup>, Kun Zhao<sup>1</sup> and Xinpeng Li<sup>2</sup>

<sup>1</sup>China Electric Power Research Institute Co., Ltd, Beijing 100192, China

<sup>2</sup>State Grid Jibei Electric Power Co., Ltd, Beijing 100032, China

**Abstract.** Based on the Monte Carlo method, an improved risk assessment method for hybrid AC/DC power system with VSC station considering the operation status of generators, converter stations, AC lines and DC lines is proposed. According to the sequential AC/DC power flow algorithm, node voltage and line active power are solved, and then the operation risk indices of node voltage over-limit and line active power over-limit are calculated. Finally, an improved two-area IEEE RTS-96 system is taken as a case to analyze and assessment its operation risk. The results show that the proposed model and method can intuitively and directly reflect the weak nodes and weak lines of the system, which can provide some reference for the dispatching department.

## 1 Introduction

With the increasing flexible DC system connected to AC system, the scale of AC/DC power system with VSC stations (Voltage Source Converter) is constantly expanding, the power grid structure is becoming complex and the power grid is facing more and more uncertainties. The potential operation risk of power grid cannot be underestimated and ignored. Once the fault occurs, it will bring serious economic and social losses to the society [1]. Therefore, it is extremely urgent to carry out the research on the operation risk for hybrid AC/DC power system with VSC stations.

In recent years, the reliability analysis and risk assessment for hybrid AC/DC power system gradually gained the attention of domestic and foreign scholars. However, the research is mostly in the early stage at present, and there is no reliability research on hybrid AC/DC power grid with VSC stations [2][3]. At the same time, the existing research evaluation period is long and mostly based on the planning perspective, which is not suitable for the dispatching operation risk assessment [4][5]. Therefore, based on the Monte Carlo method and the sequential AC/DC power flow method, this paper presents a risk assessment model and risk indices from the perspective of dispatching operation, and then carries out the research on operation risk assessment for the hybrid AC/DC power system with VSC stations.

## 2 Operation risk assessment method

### 2.1 Operation risk assessment model

The hybrid AC/DC power grid with VSC stations can be divided into generators, AC lines, VSC stations, DC lines, which all adopt the classic model of power system stability analysis [6]. According to the risk model proposed in [7] and [8], a more elaborate operation risk assessment model for hybrid AC/DC power system is proposed, as shown in Eq.1.

$$R_{isk} = \sum_{k=1}^N [p_{gen}(E_k) p_{bran}(E_k) p_{comvs}(E_k) p_{brandc}(E_k) \times S_{ev}(E_k)] \quad (1)$$

Where:  $R_{isk}$  represents a risk value, related to the severity function  $S_{ev}(E_k)$ ;  $p_{gen}(E_k)$ ,  $p_{bran}(E_k)$ ,  $p_{comvs}(E_k)$  and  $p_{brandc}(E_k)$  respectively represents the status probability of generator, AC line, VSC station and DC line under the Monte Carlo sampling time  $k$ ;  $N$  represents the total sampling time.

Generators, AC lines, VSC stations and DC lines can be modeled as a two-state model, that is, the normal operation status and the outage status [9]. Taking a VSC station as an example, the forced outage rate of a VSC station  $h$  is  $U_{comvs\_h}^{FOR}$ , which can be obtained by the state-space diagram method or the frequency-duration method [9], and the random number under the Monto Carlo sampling time  $k$  is  $R_{comvs\_h}^k$ . Then comparing the relationship between the size of  $U_{comvs\_h}^{FOR}$  and  $R_{comvs\_h}^k$  (shown as Eq.2) can be obtained the  $s_h^k$ , that is the operation status of the VSC station. According to the  $s_h^k$ , the operation status of that VSC station can be changed into operation or outage.

\* Corresponding author: [huxiaojing0394@163.com](mailto:huxiaojing0394@163.com)

$$s_h^k = \begin{cases} 0 & R_{comvs\_h}^k > U_{comvs\_h}^{FOR} \quad (\text{Normal operation status}) \\ 1 & 0 \leq R_{comvs\_h}^k \leq U_{comvs\_h}^{FOR} \quad (\text{Outage status}) \end{cases} \quad (2)$$

Due to the short operation risk assessment period, the operation status between the various components can be considered as independent [9]. Then the status probability of the VSC station under the sampling time  $k$  can be calculated, as is shown in Eq.3.

$$P_{comvs}(E_k) = \prod_h U_{comvs}^{FOR}(h) \prod_{h'} (1 - U_{comvs}^{FOR}(h')) \quad (3)$$

Where:  $h$  represents the VSC station in outage;  $h'$  represents the VSC station in operation.

Similarly,  $p_{gen}(E_k)$ ,  $p_{bran}(E_k)$  and  $p_{brandc}(E_k)$  can be obtained in this way.

## 2.2 Operation risk assessment index

In order to fully evaluate the operation risk for hybrid AC/DC power system with VSC stations, the risk indices of node voltage over-limit and line active power over-limit are proposed in this paper. The smaller the risk value, the more reliable of the power system. The purpose of operation risk assessment is to guide the power system dispatching. If the results after dispatching are used to guide the power system, it is unreasonable. Therefore, the node voltage and line power in this paper are the results of the ground-state power flow without corrective action.

### 2.2.1 Line active power over-limit risk

The risk index of the node voltage over-limit is to characterize the risk that the power system will exceed the voltage upper limit or voltage lower limit under certain operation condition. The larger the risk value is, the weaker the node is. The formula is as shown in Eq.4.

$$R_{vol} = \sum_{k=1}^N p_{gen}(E_k) p_{bran}(E_k) p_{comvs}(E_k) p_{brandc}(E_k) \times \left[ \sum_i^n \frac{e^{\max(U_i - U_i^{\max}, U_i^{\min} - U_i, 0)} - 1}{e - 1} \right] \quad (4)$$

Where:  $R_{vol}$  represents the risk value of the node voltage over-limit;  $e$  represents the natural logarithm;  $U_i$  represents the node voltage in per unit value of node  $i$ ;  $U_i^{\max}$ ,  $U_i^{\min}$  represents the maximum permissible voltage and the minimum permissible voltage in the per unit value;  $n$  represents the node number.

### 2.2.1 Node voltage over-limit risk

The risk index of the line active power over-limit is to characterize the risk that the power system will exceed the active power upper limit under certain operation

condition. The larger the risk value is, the weaker the line is. The formula is as shown in Eq.5.

$$R_{pow} = \sum_{k=1}^N p_{gen}(E_k) p_{bran}(E_k) p_{comvs}(E_k) p_{brandc}(E_k) \times \sum_m^{line} \frac{e^{\max(P_m - P_m^{\max}, 0)} - 1}{e - 1} \quad (5)$$

Where:  $R_{pow}$  represents the risk value of the line active power;  $P_m$  represents the line active power in per unit value of line  $m$ ;  $P_m^{\max}$  represents the maximum permissible active power in the per unit value;  $line$  represents the line number.

## 2.3 Operation Risk Assessment Process

The operation risk assessment of power system mainly includes system state selection, system state analysis and system risk value calculation. The assessment process is shown in Figure 1.

As the Figure 1 shows the main step:

1) Input the original data

The original data includes the VSC control mode, network topology, network parameters, component forced outage rate, the maximum number of sampling and so on.

2) System state selection

The operation status of generators, VSC stations, AC lines and DC lines are obtained based on the Monte Carlo method. Then to calculate the status probability of each part.

3) System state analysis

Change the operation status of each part and the network topology of system based on the step (2), then calculate the node voltage and line active power by the sequential AC/DC power flow algorithm.

4) System risk value calculation

When the variance coefficient is less than the given accuracy or the simulation number reaches the maximum allowed, calculate the system risk index according to the Eq.4 and Eq.5.

5) Sort risk value and output

After calculating the operation risk value, sort the risk value and output.

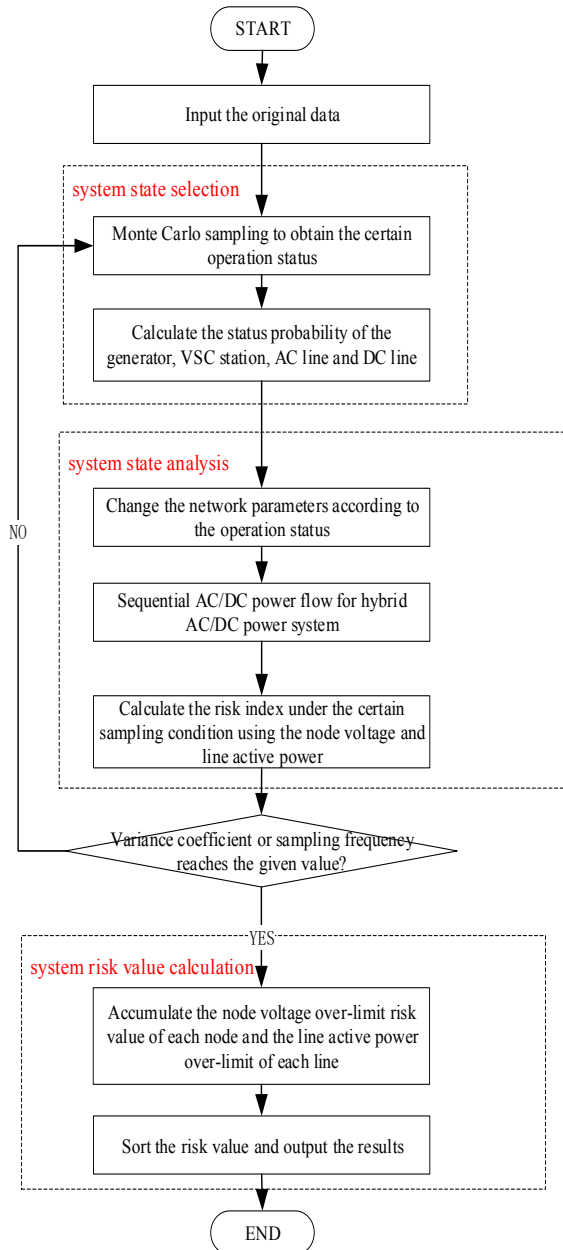

**Fig.1.** Risk Assessment for Hybrid AC/DC Power System with VSC Station

### 3 Case study

#### 3.1 Case description

Based on the simulation platform of Matlab, a modified two-area IEEE RTS-96 reliability test system is used to evaluate the hybrid AC/DC power system with VSC station. The two-zone has achieved asynchronous interconnection with three-terminal VSC-MTDC and four-terminal VSC-MTDC. The single line diagram is shown in Figure 2.

In the case, all node voltage and line power flow are used per unit value. Some data is chosen from [10]. And set the sampling time is 5000. The case has a total of 50 AC nodes and 7 DC nodes, 77 AC lines and 7 DC lines.

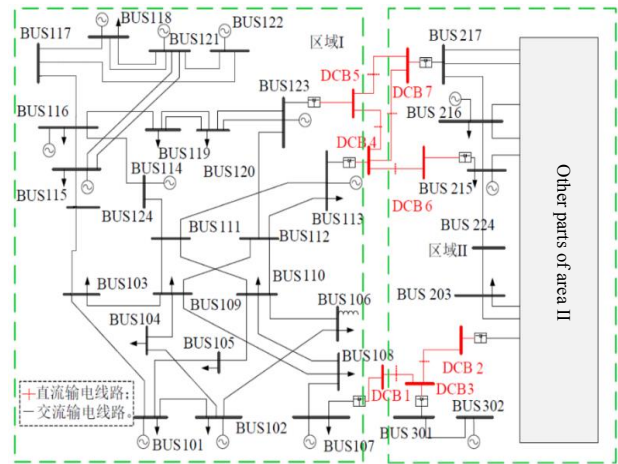

**Fig.2.** Single Line Diagram for Modified IEEE RTS-96

#### 3.2 Case results

After simulation and sorting the risk value, the results (the top 5) are as shown in Table 1 and Table 2.

**Table 1.** Risk Value of Node Voltage Over-limit.

Node	Risk Value ( $10^{-6}$ )
106	34.003
206	8.913
124	6.835
103	4.744
203	4.312

**Table 2.** Risk Value of Line Active Power Over-limit.

Line	Risk Value ( $10^{-6}$ )
1-3	54.566
107-108	16.711
211-213	5.552
111-113	5.010
216-217	2.302

Through the risk value sorting, the weak nodes and the weak line of the power system are visually shown, which can provide reference for the dispatching department. In addition, it is not difficult to find the DC lines 1-3, AC lines 107-108, 111-113, 216-217 around the VSC station with higher risk value. The reason is that

the access of the VSC station to the AC/DC power system. In order to verify this conjecture, the modified IEEE RTS-96 system is named System 1, and the system without VSC station is named System 2. The comparison results of the above weak nodes and weak lines after simulation are shown in Table 3 and Table 4.

**Table 3.** Risk Value of Node Voltage Over-limit.

Node	System 1 ( $10^{-6}$ )	System 2 ( $10^{-6}$ )
106	34.003	10.969
206	8.913	5.628
124	6.835	4.442
103	4.744	3.321
203	4.312	2.687

**Table 4.** Risk Value of Line Active Power Over-limit.

Line	System 1 ( $10^{-6}$ )	System 2 ( $10^{-6}$ )
1-3	54.566	-
107-108	16.711	$\approx 0$
211-213	5.552	0.007
111-113	5.010	4.313
216-217	2.302	0.008

From the above table, the corresponding risk value of System 2 is always lower than that of System 1, which proves that the access of VSC station increases the risk value of system. Therefore, dispatchers should pay special attention to the risk changes of nodes and lines around the VSC station.

## 4 Conclusion

Based on the Monte Carlo method, this paper establishes an operation risk model for hybrid AC/DC power system with VSC station. Then the risk indices are proposed to characterize the weak nodes and weak lines of the system. The case reflects that the model and risk indices proposed in this paper can clearly show the weak nodes and weak lines, which is achieved the risk assessment for hybrid AC/DC power system with VSC station. The result can provide reference for the dispatching department, and it is also of great significance to ensure the safe and reliable operation of the power grid.

## Acknowledgements

This work was financially supported by the Study on the Key Technology for Major Science and Technology Demonstration Project of Zhangjiakou Renewable Energy Demonstration Area in Operation and Maintenance way(52130A17005H).

## References

1. Baojie Li, Jinbo Li, Hongjie Li, et al. Analysis of Turkish Blackout on March 31, 2015 and lessons on China Power Grid[J]. Proceedings of the CSEE, **36**(21): 5788-5795(2016).
2. Zhen Ren, Jianjun He, Jun Chen. Monte Carlo-FD comprehensive method for reliability evaluation of AC/DC hybrid network systems[J]. Power System Technology, **24**(5): 13-19, 51(2000).
3. Shaoyu Xie, Xiuli Wang, Xifan Wang. Reliability estimation of AC/DC hybrid power system[J]. Electric Power Automation Equipment, **31**(7): 10-16(2011).
4. Lin Cheng, Ying Wang, Fulong Song, et al. Reliability evaluation of flexible AC/DC hybrid power grid[J]. Electric Power Construction, **38**(3): 55-62(2017).
5. Haipeng Xie, Jian He, Zhaohong Bie, et al. Reliability evaluation of large-scale hybrid AC/DC grids based on SOCP load shedding model[J]. Power System Technology, **40**(12): 3761-3767(2016).
6. Xifan Wang. Modern power system analysis[M]. Beijing: Science Press(2003).
7. J.D.McCalley, V.Vittal, N.Abi-Samra. An Overview of Risk Based Security Assessment[C]. Power Engineering Society Summer Meeting, **1**: 173-178(1999).
8. Jinghua Li, Junjun Zuo, Sai Wang. Analysis and assessment of operation risk for power system with large-scale wind power integration[J]. Power System Technology, **40**(11): 3503-3510(2016).
9. Wenyuan Li. Power system risk assessment model, method and application[M]. Beijing: Science Press(2006).
10. The IEEE Reliability Test System-1996: a report prepared by the reliability test system task for force of the application of probability methods subcommittee[J]. IEEE transactions on Power Systems, **14**(3): 1010-1020(1999).