

Environmental-economic analysis of the heating system for a single-family building

Agnieszka Jachura^{1,*}

¹Czestochowa University of Technology, Faculty of Infrastructure and Environment,
ul. Brzeznicza 60A, 42-200 Czestochowa, Poland

Abstract. This paper discusses the use of modern and effective heating systems, using fossil fuels and renewable energy sources on the example of a comparative analysis of a gas boiler and heat pump for a single-family building. The aim of the work was to conduct a comparative analysis of heating systems in terms of energy, economy and ecology. The concepts of heating systems based on a gas boiler and a heat pump are proposed. An economic analysis based on the LCC and ecological method was carried out, related to the equivalent emission, in order to compare the degree of environmental nuisance of the proposed heat sources. For the building in question, a more advantageous solution was the use of a system based on a condensing gas boiler. The economic analysis shows that in the assumed life cycle (20 years), the total cost for a heating system based on a gas boiler is lower than in the case of a heat pump by 11%. Also, the initial costs in this variant are lower by nearly half compared to the heat pump system. Environmental analyzes have shown lower annual emissions of pollutants and a 6-fold lower equivalent emission for a gas-fired heating system.

1 Introduction

As presented in the literature [1, 2], civilization progress in the second half of XX century caused a rapid increase in the energy needs of the world. The resources of energy resources available for industrial exploitation, which is mainly based on fossil fuels (coal, crude oil, natural gas), are however limited. The increase in demand and the limited resources of conventional energy resources in the aspect of energy crisis and price increases have forced a change in the way of thinking about the use of energy and energy policy. Taking into account the dependence of the modern world on non-renewable energy resources and their strategic importance in economic development, the efficiency of energy use and the search for alternative sources should be the subject of special attention. Another problem of modern energy is described in publications [3]. Energy production based on conventional technologies results in emission of harmful substances to the environment and degradation of the natural environment. In the face of noticeable climate changes, an important aspect is also the protection of the environment and reduction of emissions to the atmosphere. The EU is trying to cope with the tasks resulting from the approaching deficit of fossil fuels and

* Corresponding author: a.jachura@is.pcz.pl

maintaining the leading position in the field of environmental protection [3, 4]. Also on a national scale, ensuring energy security, quality and reliability of supplies, improving the efficiency of fuel and energy use and environmental protection are key issues. According to the work [5] in Poland, the share of the construction sector in total energy consumption is around 42%. Heating accounts for 72% of all energy needs of the building. With this in mind, saving energy and its rationalization as well as reducing emissions of environmental pollutants should manifest in particular in activities related to improving energy efficiency in buildings. The implementation of new technologies in construction and installation technology, reducing energy consumption, promoting buildings with low energy consumption and increasing the acquisition of energy from renewable sources should be the basis for achieving the assumed goals.

2 Structure and heat demand in single-family buildings

Demand for heat is one of the basic parameters characterizing the energy quality of buildings. The energy consumption for heating purposes is influenced by a number of factors, i.e. [2]: external environment parameters, building architecture, solutions construction and insulation of building partitions, type of ventilation, efficiency of systems. According to the literature review [6, 7], the energy standard of a building depends primarily on its age. Analyzing the data, it can be concluded that this is due to the change in the existing regulations on the thermal protection of buildings over the years. Despite the changes taking place in recent years, the energy consumption for heating residential buildings in Poland is significantly higher than in other EU countries. For comparison, the average annual energy consumption for heating in residential buildings in Germany is 50–100 kWh/(m²·year), in Sweden 30–60 kWh/(m²·year) [8, 9]. This indicates the possibility and the need for changes aimed at reducing energy consumption and heating costs of both newly built and existing buildings. Buildings together with technical equipment should be designed and constructed in a way that guarantees maintenance of heat energy consumption at a reasonably low level. The maximum values of the EP indicator for single-family houses, by 2021, are to amount to 70 kWh/(m²·year). According to a research report on the energy efficiency of single-family houses in Poland [10], almost 70% of buildings are heated with coal. It constitutes about 3.5 million boilers, of which a significant part is technologically outdated low-efficiency charging boilers and high emission of pollutants. The research results show that owners of single-family houses most often use the cheapest, and at the same time the least ecological, methods of heating. However, in buildings built after 2000, the share of coal heating drops significantly in favor of natural gas and biomass. Nearly 3% are other sources of heating, to which the author of the research includes solar collectors and heat pumps. These the data allow to state that in the single-family housing sector there is a significant potential for improving energy efficiency and reducing emissions of pollutants, especially for older buildings.

2.1 Heating costs in single-family buildings

According to the author of the work [11], the cost of heating the house along with heating hot domestic water accounts for 70–80% of annual expenses for house maintenance. Many factors contribute to the cost of heating building, primarily the standard of thermal insulation, the type of energy carrier and the efficiency of the heating system. In the era of rising fuel prices, choosing the right heat source is one of the key decisions an investor must make. Depending on the type of fuel or energy carrier selected, it is possible to calculate and compare the cost of producing 1 kWh of heat, and thus heating the building, with great approximation. Such analysis was made at work [11], including fuel

and electricity prices valid for July 2013. The quoted data show that the lowest operating costs are obtained for a system with a ground heat pump, a wood boiler and a coal boiler. In the middle, there are heating systems with a natural gas boiler. Electric heaters, liquid gas boilers and heating oil turned out to be the most expensive in operation. Economic analyzes connected with saving heat or choosing a heat source are also presented in the works [12, 13].

2.2 The use of renewable energy sources for heating

The limited availability of fossil fuels, higher prices and growing environmental pollution have forced the search for alternative energy sources. One of the ways to respect energy and protect the environment is replacing fossil fuels with renewable energy sources. According to data from the Central Statistical Office [14], the share of energy from renewable sources in final gross energy consumption in Poland increased in 2016 to 11.3% (in 2005 it was 7.2%) against 15% for 2020, assumed in the development strategy renewable energy. Energy obtained from renewable sources in Poland comes mainly from solid biofuels 76.62%, liquid biofuels 9.23%, wind energy 8.18%, water energy 2.33% and biogas 2.57%. Thermal energy from renewable energy sources is produced almost exclusively from solid biofuels, which in 2014 accounted for 97.91%. In single-family houses, for heating purposes, the following are usually used: solar energy, ambient energy of the building, eg atmospheric air, land, surface and ground water through the use of heat pumps and biomass energy in installations with modern boilers burning wood fuels. Choosing the right system using renewable energy should take into account the needs of buildings and its thermal characteristics, climatic and local conditions, as well as economic viability, ensuring a balance between the required investment outlays and savings obtained during operation.

3 Conceptual solutions for heating systems based on a gas boiler and heat pump for a single-family building

The subject residential building is a single-family house, one-storey, without a basement, with a non-usable attic with a usable area of 83 m², located in Czestochowa. The external walls were made of cellular concrete blocks 24 cm thick and 15 cm thick Styrofoam. The floor on the ground is insulated with floor polystyrene, 15 cm thick. Teriva I system ceiling with a 24 cm construction height was used. As a thermal insulation, mineral wool with a thickness of 20 cm was used. The building has been designed for gravity ventilation. Driven by the desire to ensure thermal comfort conditions with the lowest possible energy consumption and reduction of negative environmental impact as a heat source, two variants were chosen: a gas condensing boiler and a heat pump. For the purpose of the analysis, it was assumed that the heat distribution installation in each variant is the same. As part of the work, we will therefore compare two variants of the boiler room made in the basic variant based on the condensation gas boiler and in the alternative variant with a compressor air-water heat pump.

3.1 Heating system based on a gas boiler

The source of heat for the installation will be the dual-function gas-fired condensing boiler Cerapur Modul from Junkers with a maximum capacity of 14 kW with an integrated storage tank of 100 liters of warm utility water. The technology scheme of central heating for a single-family house is shown in Figure 1.

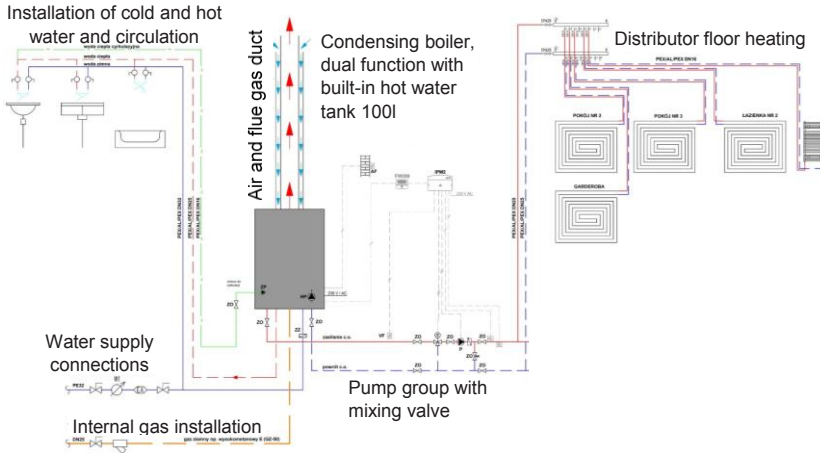

Fig. 1. Technological scheme of central heating: two-way condensing boiler with built-in 100l tank.

The boiler is equipped with smooth power regulation in the range from 20% to 100% of the maximum power. The usable water is heated by a plate heat exchanger and stored in a container. The boiler has a built in electronic heating circuit pump controlled by a weather regulator and a pump that charges the hot water storage tank. The boiler is equipped with all safety and regulation devices. The combustion air supply and flue gas discharge over the building are provided by an air and flue chimney system.

3.2 Heating system based on a heat pump

In the alternative variant, a Junkers compressor-type air-water heat pump was chosen as a source of heat for central heating and hot water preparation: external module AE 80-1 plus internal module ASC 160. The diagram of the heat pump in a single-family home is shown in Figure 2.

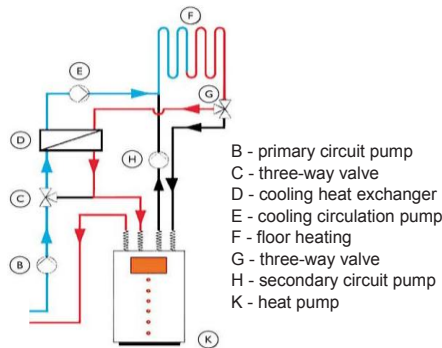

Fig. 2. The scheme of operation compressor air-water heat pump.

The pump will work in mono energy mode. At outdoor temperatures below the bivalent point, the difference in power between the heat demand for the building and the power achieved by the heat pump at a given outdoor temperature will be covered by additional electric heaters built into the indoor module. In Poland, for an external processing temperature of -20°C, a bivalent point value in the range of -5°C to -8°C is recommended so that the share of electricity is as limited as possible. The indoor module has a built-in jacket water heater with a capacity of 165 liters. At outdoor temperatures below -20°C, the heat pump stops automatically and the function is taken over by an electric addition.

4 Methodology

4.1 Technical and economic analysis based on the LCC method

The basic criterion in the selection of the heating system for a residential building is the technical and economic assessment. In this study, the economic analysis was carried out using the LCC (Life Cycle Cost) method. This method allows to estimate the total investment and operating costs of the heating system in the assumed life cycle based on the following equation:

$$LCC = IC + \sum_{t=1}^n \frac{COF_t}{(1+s)^t} \cdot PLN \quad (1)$$

where:

IC – investment costs, PLN,

COF – annual operating costs, PLN,

n – assumed number of years of system life cycle (20 years),

t – another year of system use,

s – real rate of interest (discount), %.

The economic calculation according to equation (1) is to a large extent dependent on the real interest rate. According to NBP data, the real interest rate has changed significantly over the years and is difficult to predict accurately. In connection with the above, the economic account in this work will be carried out on the basis of fixed prices. For the purpose of estimating the life cycle costs of the heating system, capital expenditures were limited to the costs of purchase and commissioning of the heating system. The cost of purchasing elements of heating systems was adopted according to materials and catalogs of installation companies. The costs of assembly, earthworks and commissioning of the installation were estimated as 10% of capital expenditure. The costs of using the system were taken as the sum of gas costs consumed by the gas boiler and electricity consumed by auxiliary devices in the basic variant, as well as the cost of electricity consumed by the heat pump and auxiliaries in the alternative variant, as well as service costs during the system operation period. The price of gaseous fuel, the fixed and variable fee rate as well as the subscription fee was adopted on the basis of the gas supplier tariff. The values of individual components of the total price were adopted on the basis of the electricity supplier tariff.

4.2 Emission of pollutants introduced into the atmosphere

The volume of emissions of particular pollutants emitted from the emission source will be calculated using the index method according to the following equation:

$$E_t = C \cdot W_t \text{ [kg/year]} \quad (2)$$

where:

E_t – actual emission of pollutants with an index t , kg/year,

C – annual consumption of energy carrier, kWh/year or m³/year,

W_t – pollutant emission index with an index t , kg/kWh or kg/m³.

The values of emission factors for calculations are adopted in accordance with the data provided by the National Center for Emissions Balancing and Management [15]. Equivalent or substitute emission is the total quantity of pollutant emissions from a specific emission source converted into the emission of sulfur dioxide. It allows to compare the degree of nuisance of pollution sources introducing contaminants with a different degree of

toxicity into the air. We calculate the equivalent emission by adding up the actual emissions of individual pollutants from the source being assessed multiplied by their toxicity coefficients. Values of pollutant toxicity coefficients are determined on the basis of data from the current Regulation on reference values for certain substances in the air [15].

5 Results of technical-economic and environmental analysis

For a single-family house, the total design heat load was 5.58 kW, where the projected loss of heat by penetration was 4.08 kW and the design ventilation heat loss was 1.5 kW. Average hourly water demand amounted to 1.17 kW (three users). Annual consumption of final energy supplied to the building for heating and domestic hot water preparation, depending on the heat source used, is presented in Table 1.

Table 1. The annual demand of the building for the final energy.

| Variant | | Heating | HDW | Auxiliaries | Sum |
|----------------------------|------------|----------|---------|-------------|----------|
| Basic variant | [kWh/year] | 12371.67 | 4614.64 | 424.51 | 17410.82 |
| | Part [%] | 71.06 | 26.50 | 2.44 | 100 |
| Alternative variant | [kWh/year] | 4153.35 | 1508.63 | 358.57 | 6020.55 |
| | Part [%] | 68.99 | 25.06 | 5.96 | 100 |

When using heat pump, final energy consumption is 6020.55 kWh/year and is almost three times lower than for gas boiler (17410.82 kWh/year). Energy consumption in the baseline variant for heating purposes is 71%, and is comparable to the alternative variant consumption (69%). A similar situation was observed in the case of demand for heat treatment. The largest difference was demonstrated in the case of auxiliary equipment, which in the basic variant absorbs 2% of the total final energy, and in the alternative 6%. Table 2 presents a comparison of LCC cost components for the analyzed variants.

Table 2. Summary of LCC cost components for heating systems for the analyzed building.

| Components LCC | Basic variant | Part, % | | Alternative variant |
|---------------------------------|---------------|---------|----|---------------------|
| | | | | |
| COF gross for 1 year, PLN | 4393.66 | | | 3930.22 |
| IC gross, PLN | 27280.00 | 24 | 39 | 50490.00 |
| COF gross for n = 20 years, PLN | 87873.27 | 76 | 61 | 78604.33 |

When using a gas condensing boiler, capital expenditures amount to PLN 27280 and are lower by nearly half than for a heat pump system (PLN 50490). However, the higher capital expenditures incurred in the heat pump system are characterized by lower annual operating costs of PLN 3930, which for the gas boiler are at the level of PLN 4394. During 20 years of using a system based on a condensing gas boiler, initial costs account for 24% of total costs. In the case of a heat pump system, capital expenditures amount to as much as 39% of total costs. Operational costs account for 76% and 61%, respectively, and depend to a large extent on natural gas prices in the first option and electricity prices in the second option. From total LCC costs for the analyzed building, it appears that a more advantageous solution is a heating system based on a gas boiler. The total cost of LCC incurred in the 20-year period of use is lower for it by PLN 13941 in relation to the LCC cost of the heat pump system, which is a saving of 11% over the whole life cycle. A comparison of the life costs of the proposed heating systems over 20 years of use is shown in Figure 3. The blue line shows the costs incurred when using a system equipped with a gas boiler, while the red line reflects the costs incurred when operating the heat pump.

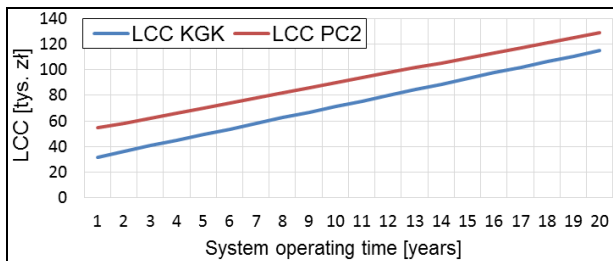

Fig. 3. Comparison of life-cycle costs incurred for a condensed gas boiler system with system life cycle costs based on an air-to-water compressor heat pump.

Starting from the first year of the investment, throughout the life of the system, the costs incurred for a heating system with a heat pump are higher than the costs for a gas boiler. Due to lower annual operating costs, the profits from the use of the condensing gas boiler in relation to the heat pump are minimally reduced from year to year, however, equalization of life cycle costs for both systems is not possible. Analyzing LCC life cycle costs, it can be concluded that a better option is to adopt a variant with a condensing gas boiler, which in the adopted 20-year life cycle can bring nearly PLN 14 thousand of savings. In order to assess the impact of heat energy production in the analyzed building on the environment, the amount of main pollutants emitted to the air was calculated, i.e.: SO₂, NO_x, CO, CO₂ and dust. The emission values of all emitted pollutants are lower in the case of a heating system based on a condensing gas boiler. On the basis of the annual emission volume, the reduction of the amount of pollutants emitted in weight units and the percentage reduction rate were calculated. In order to compare the degree of environmental nuisance of the proposed heat sources, an equivalent emission was calculated. The results obtained are shown in Table 3.

Table 3. Equivalent emission from heating systems.

| Emitted pollution | Emission, kg/year | | Ecological effect, kg/year | Emission reduction, % | Equivalent emission, kg/year | |
|----------------------------------|-------------------|---------------------|----------------------------|-----------------------|------------------------------|---------------------|
| | basic variant | alternative variant | | | basic variant | alternative variant |
| SO ₂ | 0.791179 | 9.4643 | -8.673121 | -1096.23 | 0.791179 | 9.4643 |
| NO _x | 2.798452 | 6.315554 | -3.517102 | -125.68 | 1.399226 | 3.157777 |
| CO | 0.563771 | 1.408808 | -0.845037 | -149.89 | – | – |
| CO ₂ | 3446.634 | 4969.432 | -1522.798 | -44.18 | – | – |
| Dust | 0.027943 | 0.385315 | -0.357372 | -1278.93 | 0.013971 | 0.192657 |
| Total equivalent emission | | | | | 2.204377 | 12.81473 |

In the variant with heat pump, there is a significant increase in the emission of pollutants relative to the gas boiler. In both cases, more than 99% of the total emission is carbon dioxide. It should be noted, however, that in the case of a condensing gas boiler we deal with a low emission, affecting the environment locally. In the case of electricity used for heat pump operation, we deal with high emission, where pollutants are emitted in power plants and are transferred over greater distances. The equivalent emission from the heat pump is 12.82 kg/year and is nearly 6 times higher than the system based on the condensing gas boiler, for which the calculated equivalent emission is 2.20 kg/year. Comparing the results of the environmental analysis, we come to the conclusion that the choice of a variant of a heating system based on a condensing gas boiler is more beneficial

because it has less impact on the environment globally, taking into account both the annual emission of individual pollutants as well as the equivalent emission.

6 Conclusions

On the basis of the comparative analysis of the heating system, taking into account technical, economic and environmental criteria, it appears that for a single-family building being analyzed, a more advantageous solution is the use of a system based on a condensing gas boiler. The economic analysis showed that the total cost for a gas boiler based heating system is 11% lower compared to a compressor heat pump. The environmental assessment also showed that both the annual emission of individual pollutants as well as the equivalent emission are lower for a heating system based on a condensing gas boiler. However, it should be borne in mind that in the case of a boiler, we affect the environment locally, near a heated building. Heating by means of a heat pump does not cause emissions in the vicinity of the heated object. Unfortunately, the generation of electricity used for compressor heat pump operation is associated with the emission of harmful substances in power plants and combined heat and power plants. In Poland, electricity is produced mainly in coal-fired plants, the combustion of which is associated with a significant environmental impact, and also characterized by low efficiency of electricity generation. Due to the above reasons, the emission of pollutants from the system based on the compressor heat pump turned out to be higher than for the system based on the gas boiler. The use of a condensing gas boiler as a heat source allows for effective use of chemical energy contained in gas fuel and reducing its impact on the natural environment, and ensures economic viability, consisting of a balance between the required investment costs and energy costs during the operation of the building.

The material has been prepared in terms of Czestochowa University of Technology statutory research BS/PB-407-302/11 'Energy-efficient and environmentally sustainable supply systems of buildings in heat, coldness and electricity'.

References

1. G. Triantafyllopoulos, A. Kontses, et al., *Energy* **140**, 365–373 (2017)
2. I. Tibermacine, N. Zemmouri, *Energ. Procedia* **139**, 664–669 (2017)
3. K.S. Reddy, H. Sharon, *Energ. Convers. Manage.* **151**, 259–285 (2017)
4. M. Turski, R. Sekret, *E3S Web of Conferences* **22**, 00180 (2017)
5. M. Grudzińska, E. Jakusik, *Indoor Built Environ.* **0**, 1–16 (2016)
6. M. Papineau, *Energ. Econ.* **64**, 63–76 (2017)
7. W. Qingqin, Z. Miao, *Sustain. Cities Soc.* **14**, 1–4 (2015)
8. T. Schütz, et al., *Energy* **139**, 895–915 (2017)
9. G. Nair, S. Azizi, T. Olofsson, *Energy Procedia* **132**, 994–999 (2017)
10. Ł. Pytliński, Research report, Energy efficiency in Poland, Cracow (2014)
11. Production costs of 1 kWh of heat from gas, oil, electricity, *Instal Reporter* **09**, (2013)
12. O. Mřrck, K. E. Thomsen, J. Rose, *Appl. Energ.* **97**, 319–326 (2012)
13. P. Tuominen, J. Forsstr, J. Honkatukia, *Energ. Policy* **52**, 181–189 (2013)
14. Central Statistical Office, Warsaw (2017)
15. Emission indicator, KObiZE, Warsaw (2015)