

Concept of experimental platform to investigate aeroponic systems in microgravity conditions

Anna Jurga^{1,*}, *Joanna Kuźma*², *Paweł Płuszka*², *Piotr Chmielewski*², *Edyta Bobrowska*³,
and *Maciej Draguła*⁴

¹Wrocław University of Science and Technology, Faculty of Environmental Engineering,
Wyb. Wyspińskiego 27, 50-370 Wrocław, Poland

²Wrocław University of Science and Technology, Faculty of Mechanical and Power Engineering,
Wyb. Wyspińskiego 27, 50-370 Wrocław, Poland

³Wrocław University of Science and Technology, Faculty of Fundamental Problems of Technology,
Wyb. Wyspińskiego 27, 50-370 Wrocław, Poland

⁴University of Wrocław, Faculty of Physics and Astronomy, pl. M. Borna 9, 50-204, Wrocław, Poland

Abstract. The article presents the concept of experimental research system to investigate aeroponic cultivation in microgravity condition. The main scientific objective is to define the forces acting in droplet-root system exposed to microgravity conditions especially the adhesion and cohesion phenomena. The concept of a research platform is presented in this paper and includes electrical, hydraulic and optical system.

1 Introduction

Future colonization of space will be strongly dependent on plants cultivation. However, the classic - soil plants cultivation is not feasible in lower or microgravity conditions. Hence, there is a need to search another, suitable kind of cultivation. Recently, soilless cultivations are becoming more popular, due to its known benefits compared to conventional solutions. An example of a soilless cultivation is aeroponic. Aeroponic is a system of growing plants in the air. Required nutrient and water delivery is implemented by spraying roots with nutrient solution in a form of a mist. An optimal environment allows to repeatedly accelerate plant growth and to reduce the required amount of water in comparison to a classic method of cultivation [1]. However, while in terrestrial condition the behavior of sprinkled drops is well known, there is no data how microgravity condition will affect them. Key factor to build an effective aeroponic system is to investigate adhesion forces between a root and water drops exposed to microgravity condition. The conducted literature review shows that the investigation of the cohesion effects in the aeroponic microgravitational systems has not been recorded yet. However, another soilless cultivation type (hydroponic) is examined in space and for that area some references can be found [2–7]. Although all papers discuss possible ways to lead the cultivation and variety of likely encountered problems, none of them conducts an actual experiment in microgravity condition. Also none of them was focused on microgravity impact of the droplets on the roots. The studies of spraying water under reduced

* Anna Jurga: anna.jurga@pwr.edu.pl

gravity has been also recorded [8–11]. The researchers were mostly interested in heat transfer characteristics, occurring during spraying of cooling water on hot surface. These works give meaningful insight into the non-isothermal spraying processes in gravity absence.

The concept of an experiment shown in this paper is designed to be performed in microgravity obtained artificially during parabolic flight in an aircraft [12]. The main goal of this study is to model mathematically the adhesion effects at water-root interphase in absence of gravity. The research outcomes are intended to preliminarily understand fundamentals of phenomenon and draw attention of scientific community to such experiments. Second aim is to define the optimal values of process variables to minimize the water demand needed for aeroponic cultivation of edible plants. Further outcomes can be achieved by optimization of design and exploitation of such systems.

2 Mathematical description of wetting phenomenon

As the main scientific objective of the project is to define the forces acting in droplet-root system exposed to microgravity conditions, it is obvious, that the adhesion and cohesion phenomena are the key factors. The microgravity conditions are expected to change the nature of interaction between roots and droplets. The first objective of experiment is to derive how significant lack of gravity is and how it influences the system's behavior. Understanding of physics present in the process will be further used to investigate an effect of these forces on aeroponic plant irrigation.

One of the crucially important parameters of wetted body is the capillary length κ . It defines the shape of external droplet's surface. According to the wetting theory shown below the value of the gravity field effects have negligibly small impact:

$$\kappa^{-1} = \sqrt{\frac{\gamma}{\rho g}} \quad (1)$$

where: g – gravitational acceleration ($\text{m}\cdot\text{s}^{-2}$), ρ – liquid density ($\text{kg}\cdot\text{m}^{-3}$), γ – surface tension of fluid ($\text{N}\cdot\text{m}^{-1}$). Hence, capillarity phenomenon is strictly bonded to linear size of liquid droplet. For radii $r < \kappa^{-1}$ the liquid portion is assumed to be free from gravity impact as the capillary effects are dominant. Typically, in the Earth conditions for various substances, κ value reaches few millimeters. During parabolic flights the feasible microgravity level is order of 10^{-2} . Therefore, capillarity effects may be acting effectively on ten times larger distance comparing to 1g Earth conditions. As it is presented in the Figure 1, in presence of the gravity the larger droplet is, the more flattened it becomes [13].

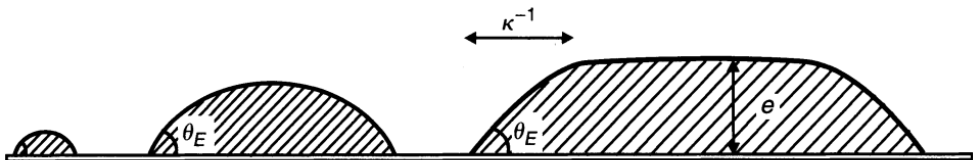

Fig. 1. Evolution of droplet's shape with capillarity length distance [12].

Second important quantity in terms of wetting process is contact (or wetting) angle, denoted in the Figure 2 as θ_E (°). The contact angle describes the shape of interphase surface. Analysis of wetting for solid particles leads to so-called Young’s relation:

$$\cos \theta_E = \frac{\gamma_{SG} - \gamma_{SL}}{\gamma_{GL}} \tag{2}$$

Where *SO*, *SL* and *GL* indexes means the solid-gas, solid-liquid and gas-liquid interphases respectively. The adhesion work W_a is given by:

$$W_a = \gamma_{SG}(1 + \cos \theta_E) \tag{3}$$

As provided in the literature [13, 14], contact angle could be easily examined experimentally. That is very useful for performing correlations between numerical predictions and experimental measurements. There are two possible variants of wetting phenomenon which are known as partial wetting and total wetting. These regimes are described by respectively negative and positive values of spreading parameter denoted as *S*. The formula for spreading parameter connects the surface tension γ and wetting angle θ_E :

$$S = \gamma(\cos \theta_E - 1) \tag{4}$$

The behavior of droplets in terms of spreading parameter is illustrated in the Figure 2. Negative *S* value means that droplet does not fully spread on the surface, during the wetting but rather forms a spherical cap in on the substrate. The shape of the interface is an effect of the force equilibrium. When the spreading parameter value is positive, the whole surface of substrate is wetted with liquid phase. The spreading of droplets is complete and results in establishing the nanoscopic film of liquid layer. One can conclude that such situation is beneficial for the aeroponics, because the fraction of water contacted with a root is maximal. The research conception proposed in this paper could lead to optimizing the system to be working in the total wetting regime. That could be feasibly done by a comparative study of the velocity and impact angle of water-salt feeding solution.

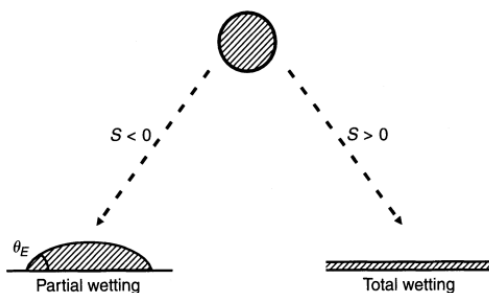

Fig. 2. The two sessile regimes for sessile droplets [15].

The nozzle hydrodynamics can be described with a non-dimensional Reynolds’s criteria and Weber’s numbers. The Reynolds number for droplet is the ratio between forces of inertia and forces of viscosity acting on the droplet. The Weber number is a dimensionless value used for analyzing multiphase flows where interphase surface can be precisely distinguished. It expresses the ratio of inertial forces and the surface tension forces. What is more, it indicates whether the kinetic or surface tension energy is dominant in flow.

3 Experiment design overview

The general view of the experiment is presented in the Figure 3. Roots of a previously selected plant are sprayed with water containing small amount of nutritious elements e.g. nitrate, phosphates. The magnified picture of root's surface is captured by camera vision system (presented in chapter 4.2). It provides highly magnified 3D slow motion video, which enables the observation of the droplets' motion and process of their attaching to the roots. The images allow to estimate the value of contact angle as well as acting forces and a percentage of attached drops. To obtain reliable data, velocity of the drops is manipulated by changing a throughput of nozzle. The varying parameter is the angle of impact of the drops. Additionally, the experiment is going to be performed with investigation of different parameters. This is due to parabolic flight cycle, which has consecutively repetitive stages [12].

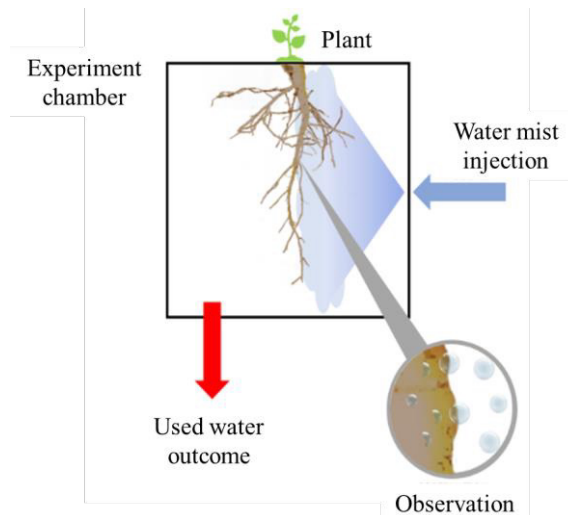

Fig. 3. Experimental procedure scheme.

The proposed experimental rack is shown in the Figure 4. Since the experiment is designed to be placed on the board of an aircraft, several safety requirements have been taken under consideration in the design process (especially assurance of leak-proof). The main construction element is BOSCH aluminum profile (9) with angle brackets for more strength, which is sealed with transparent polycarbonate plates. The whole experimental stand is divided into two zones. First one, zone A is the actual experimental chamber, and aims to keep sprayed water in a closed space. Latter one is, zone B, where the hydraulic system is placed. This zone provides protection from water spilling out from water tanks, pump *etc.* to the airplane environment. Experiment cycle is conducted as follows. Water is delivered to the experimental chamber (A) from a clean water tank (5) by a pump unit (6). The plant roots are sprayed (7) by an atomized nozzle (8). Observations are conducted with a use of an optical system (2). The excessive water which did not get attached to the roots is transported out of the chamber to the used water tank (4). There is no connection between tanks, so the system is not operating in a closed loop.

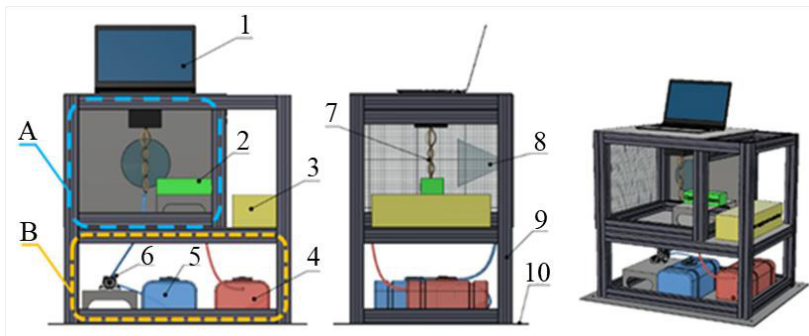

Fig. 4. Concept of an experimental test stand: 1 – laptop, 2 – optical system, 3 – power supply and control system, 4 – used water tank, 5 – clean water tank, 6 – pump unit, 7 – plant root, 8 – nozzle (water mist injection), 9 – main construction structure, 10 – base mount plate, A – experimental chamber zone, B – hydraulic system zone.

4 Description of test setup and experimental in-flight procedures

4.1 Hydraulic subsystem

The hydraulic system is shown in the Figure 5. The main aim of a hydraulic system is to deliver the nutrient solution (water supplemented with nutrients) to the experimental chamber TC. The nutrient solution is stored in a tank Z1, and used water is stored in a tank Z2. Each container (Z1, Z2, TC) is equipped with pressure equalizers (C, C1, C2) in this concept is designed as an elastic hose rolled in the form of a coil. This solution guarantees the system to be leakproof. The filter F1 prevents unwanted particles from entering the pump. The nutrient medium is pumped by the diaphragm pump P. Complete system's work is based on the mass flow control, which is maintained by the mass flow controller (MFC). When airplane is in zero-gravity condition nutrient solution is transported through the conduit (T2) and then reaches the nozzle (IN) through which is injected into the experiment chamber in a form of a mist. Further, airplane reach 1g condition again and the condensed medium falls by gravity forces through the conduit (T3) and reaches the used water tank (Z2).

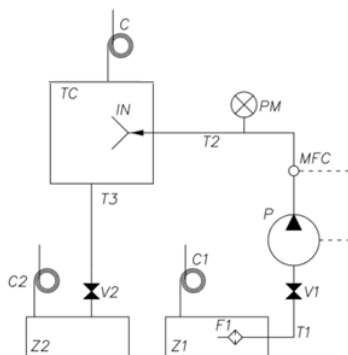

Fig. 5. Hydraulic system scheme: TC – experimental chamber, Z1 – clean water tank, Z2 – used water tank; P – pump; IN – nozzle; F1 – filter; T1, T2, T3 – pipes; V1, V2 – valves; C, C1, C2 – pressure equalizer; PM – pressure meter; MFC – mass flow regulator.

4.2 Optical subsystem

To estimate the value of the contact angle and the forces between micrometer-sized water drops and the root as well as the percentage of drops attached to the root, optical imaging system of 2 cameras is designed. It enables an acquisition of 3D images. The system allows the droplet's interface to be investigated with micrometer resolution. It is designed to observe water droplet with the size of a 50 μm . The optical system is presented in the Figure 6. It consists of 0.58-7x zoom lens ZL along with 2x extension tube ET and 1.5x or 2x magnifying lens MLA. All elements are integrated with the camera using C-mount adapter C-MA. Together, these components provide a net magnification up to 28x. The contrast between the droplets and the root can be insufficient because of the droplet's transparency. To enhance the contrast, a dye could be introduced to water. The need of this idea will be verified in the experimental test. Large magnification results in imaging only a fragment of the root. The size of this fragment is determined by the field of view (FOV). In the most unsuitable situation FOV will equal 400 μm what corresponds to a rectangle with dimensions of 320x240 μm . This size is appearing with the 28x magnification setting of the optical system. The estimation of the maximum number of drops observed simultaneously should be based on the assumption that the FOV is completely filled with drops that are arranged in a matrix scheme. Following that we can estimate that about 24 drops can fit in a described earlier rectangle. However, a result of that experiment can show that only 2 drops will be observed per parabola, contradicting the assumption with the actual behavior. The optimal result can be achieved because every flight campaign consists of three flights with thirty parabolas per flight. Therefore, it can be a non-ideal case data collection, the observation of the microdroplets optical images should give satisfactory statistical basis

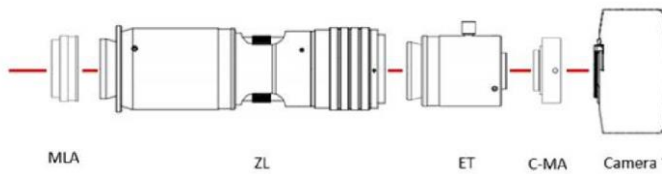

Fig 6. Scheme of the optical system: MLA – magnifying lens attachment, ZL – zoom lens, ET – extension tube, C-MA – c-mount adapter.

4.3 Electrical system

Electrical system is schematically shown in the Figure 7. The system is controlled from a laptop which is powered by a power supply provided in the airplane. The computer is responsible for the camera control. All data is saved on the hard disk. The logic of the controller is programmed before flight. The controller system is responsible for the pump performance and the MFC system. It also controls the overall lightning of the experiment chamber. The water pump is facilitated with power supply with an additional fuse, due to possibly large inrush of a current value.

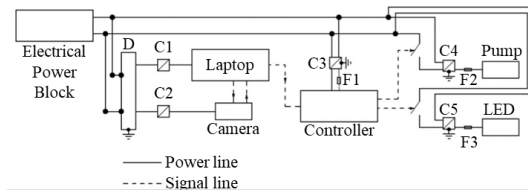

Fig. 7. Wiring diagram: C – AC/DC converter, D – distribution socket, F – fuse.

4.4 In-flight procedures

The experiment will be conducted in parabolic flight, where a microgravity condition occurs. The parabolic flight is divided into five correlated segments [12]. Each part is characterized with a specific flight conditions which define each stage of the experimental procedure. In the Figure 8 all stages of one full flight cycle (called parabola) are presented. Before starting the parabola in 1g condition (green segment) no action is proceeded. On starts of hyper gravity (1.8g, yellow segment) machine vision system is activated. In 0g condition (blue segment) one of the operators manually launches the water injection system. System stops automatically after five seconds. When water is injected to the chamber the machine vision system is working with the highest possible quality. The second operator observes and controls the machine vision data on laptop's screen. In a second hypergravity period the cameras are still recording, as it is assumed that 1,8g conditions can initiate spontaneous fall of droplets from the roots' surface. In 1g conditions water flow rate in hydraulic system will be changed for the next examined value. The procedure will be repeated in a next parabola.

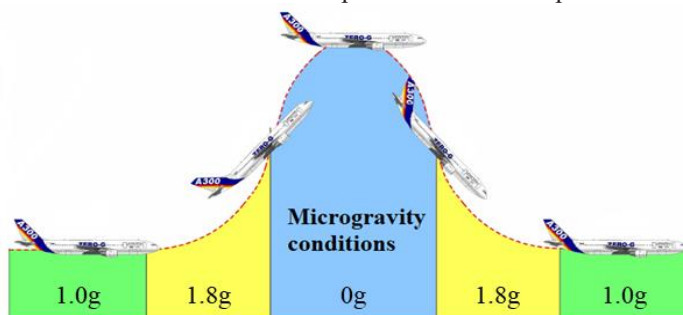

Fig. 8. Parabola flight stages [11].

5 Summary and conclusions

Space technologies differ extensively from their analogs on Earth. It means that any space engineering experiment must be performed in conditions which are simulating the real extraterrestrial conditions. This type of problems can be modelled numerically, but the full picture of study can be covered only after an experimental verification in the microgravity condition. The unusual behavior of the matter can reveal the importance of some factors which are normally neglected on Earth, but they can play far more significant role in terms of gravity absence.

If the wetting efficiency per unit of liquid is relatively high, it may reduce the amount of feed watering the plants. This is extremely valuable in terms of space cultivations delivery of any matter into space. Usually, it is strongly constrained and very costly. Hence, total wetting conditions are promoting the space application of aeroponic growth systems. All experimental findings are planned to be supported with the numerical study of the two-phase fluid flow. The simulations will be performed in one of the CFD (Computational Fluid Dynamics) software packages (ANSYS Fluent, OpenFOAM). The numerical analysis of two-phase spraying conditions in microgravity should be a valuable tool to propose the optimal design concept before building of the experimental setup. Moreover, measured data extracted from experiment can be used later to validate the calculations. Hence, versatile numerical tool could be obtained and used for future projects. The authors believe that presented research proposal could be an attractive field for further investigation. Understanding the physics behind the microgravitational aeroponics could be the milestone in a space life support systems development.

References

1. A. Komosa, W. Breś, A. Golcz, E. Kozik, *Żywnienie roślin ogrodniczych – Podstawy i perspektywy*, Powszechne Wydawnictwo Rolnicze i Leśne Sp. z.o.o. Poznań 2012, ISBN: 978-83-09-01141-5, 283–321
2. C. Zeidler, V. Vrakking, M. Bamsey, L. Poulet, P. Zabel, D. Schuber, C. Paill, E. Mazzolen, N. Domurath, *Open Agriculture*, **2**:116–132 (2017)
3. P. Zabel, M. Bamsey, D. Schubert, M. Tajmar, *Life Science in Space Research*, **10**: 1–16 (2016)
4. O. Monje, G.W. Stutte, G.D. Goins, D.M. Porterfield, G.E. Bingham, *Advances in Space Research*, **31**:151–167 (2003).
5. R. Ferl, R. Wheeler, H.G. Levine, A. Paul, *Current Opinion in Plant Biology*, **5**: 258–263 (2002)
6. C. Lasseur, J. Brunet, H. de Weever, M. Dixon, G. Dussap, F. Godia, N. Leys, M. Mergeay, D. Van Der Straeten, *Gravitational and Space Biology*, **23**: 3–12 (2010)
7. K. M. Baysinger, K. L. Yerkes, T. E. Michalak, *Design of A Microgravity Spray Cooling Experiment*, 42nd AIAA Aerospace Sciences Conference and Exhibit (2004)
8. K.I. Yoshida, A. Yoshiyuki, T. Oka, Y. Mori, A. Nagashima, *Journal of Heat Transfer*, **123**: 309–318 (2001)
9. M. Kato, A. Yoshiyuki, Y. Mori, A. Nagashima, *Journal of Thermophysics*, **(9)2**: 378–381 (1994)
10. L. Elston, K. L. Yerkes, S. K. Thomas, J. McQuillen, *Journal of Thermophysics and Heat Transfer*, **(23)2**: 571–581 (2009)
11. R. P. Selvam, M. T. Hamilton, J. E. Johnston, E. A. Silk, *Journal of Thermophysics and Heat Transfer*, **(23)3**: 560–570 (2009)
12. ESA User Guide to Low Gravity Platforms: Parabolic Flights, European Space Agency (2014).
13. P.G. De Gennes, Brochard – Wyart, D. Quéré, A. Reisinger, B. Widom, *Capillarity and Wetting Phenomena: Drops, Bubble Pearls, Waves*, Springer -Verlag, New York (2004)
14. T. Kajiya, F. Schellenberger, P. Papadopoulos, D. Vollmer, H.-J. Butt, *3D Imaging of Water-Drop Condensation on Hydrophobic and Hydrophilic Lubricant-Impregnated Surfaces*, *Scientific Reports*, **6**:23687 (2016)