

Recovery time reduction of a damaged 6-35 kV transmission line after double earth fault applying the iteration fault location method

A.L. Kulikov^{1*}, V.J. Osokin¹, and M.D. Obalin¹

¹NSTU n.a. R.E. Alekseev, Nizhniy Novgorod, Russian Federation

Abstract. The task of determining the fault location on a power line is difficult and the longest operations to restore damaged areas of the network. Determining fault location with double earth faults is a priority due to the high wear of medium voltage networks and the absent of currently accurate algorithms. The usage of the phase coordinates method allows to obtain the calculated relations for determining the distances to the nearest and furthest point of damage. A significant increase in the accuracy is achieved by using iterative recalculation, the essence of which is to rectify such parameters as the transient resistance, the voltage at the neutral point of the load and the distance to the damage. The proposed algorithms allow reducing the calculation error and reducing the bypass zone of the damaged line, which in turn determines the power transmission line recovery time and increases the reliability of the power supply network.

1 Introduction

The task of determining the fault location on a power line is difficult and the longest operations to restore damaged areas of the network. Accurate and efficient fault location on power lines affects amount of damage caused by power supply interruptions and reduction of the transmitted electricity quality. In medium voltage electrical networks, there are mainly used fault location methods based on unilateral measurement of the emergency mode parameters [1-3, 6-10], which allow to determine distances to phase-to-phase faults. A phase-to-earth fault can be determined using expensive specialized indicators (for example, indicating the direction of flow of the capacitive fault current, active sensing methods [4], and wave method of fault location [13]). Determining fault location with double earth faults is a priority due to the high wear of medium voltage networks and the absent of currently accurate algorithms. Despite the variety of software and hardware offered, the problem of fault location at double earth fault does not to date have a generally recognized solution [5-10], and modern methods that allow calculating the distance to the fault locations have a large error.

2 The fault location algorithm for double earth faults on different lines.

The developed method of fault location at double earth fault on different lines is based on the simulation modeling and following statistical processing of the results [9-15]. The parameters of the simulation model and the developed methods of fault location are below. Calculation of the distances to the damage sites with double earth fault on different lines is fulfilled according to the schemes shown in Figure 1.

The components of the transient resistance R_{t1} are resistance of foreign objects between the wire and ground or support, ground resistance of the support.

During the calculation, the following assumptions were made:

- 1) the three-phase elements of the system are assumed to be symmetric;
- 2) capacity admittance of transmission lines is not taken into account;
- 3) the transition resistance is purely active;
- 4) backfeed of the short-circuit point by the load current is absent.

The use of the scheme shown in Fig. 1, in phase coordinates [7], allows obtaining expressions to determine distances to the near and far points of damage with double earth fault on different lines.

* Corresponding author: inventor61@mail.ru

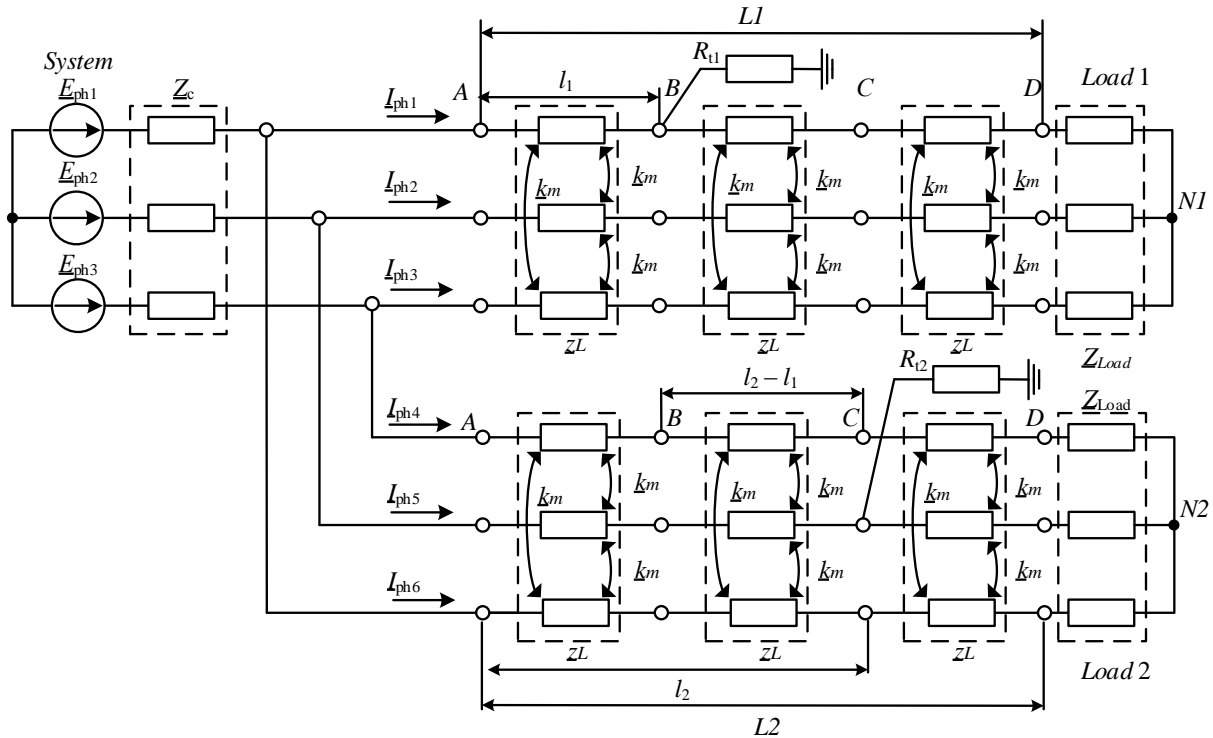

Fig. 1. The scheme for replacing the network in the phase «Ph1» in double fault mode on different lines at a distance l_1 and phase «Ph2» at a distance l_2

In figure 1, the following designations are accepted:
 $E_{ph1}, E_{ph2}, E_{ph3}$ – is the equivalent of system electromotive force; Z_S – equivalent system resistance; z_L – line resistivity; k_m – ratio of mutual induction; z_{Load} – equivalent load resistance; R_{t1}, R_{t2} – transient resistance in the places of short circuit; l_1, l_2 – distances to near and far ground faults.

In general terms, the calculation expressions look like this:

$$l_1 = \frac{X_{ph1}}{(x_L + x_{m12} + x_{m13})}, \quad (1)$$

$$l_2 = \frac{X_{ph2}}{(x_L + x_{m21} + x_{m23})}, \quad (2)$$

where

$$x_{m12} = \text{Im} \left(z_m \cdot \frac{I_{ph11}}{I_{ph21}} \right); x_{m13} = \text{Im} \left(z_m \cdot \frac{I_{ph13}}{I_{ph11}} \right);$$

$$x_{m21} = \text{Im} \left(z_m \cdot \frac{I_{ph21}}{I_{ph22}} \right); x_{m23} = \text{Im} \left(z_m \cdot \frac{I_{ph23}}{I_{ph22}} \right)$$

– resistivity of mutual inductance of the nearby phases regarding the damaged one; X_{ph1}, X_{ph2} – calculative inductances proportional to the distances to the faults; I_{ph11} – the current of the damaged phase of the first line; I_{ph22} – current of the damaged phase of the second line; I_{ph12}, I_{ph13} – currents of the undamaged phase of the first line; I_{ph21}, I_{ph23} – currents of the undamaged phase of the second line.

The verification of the proposed fault location method for double earth fault on the different lines was carried out according to the scheme presented in Figure 2, by simulation modeling of the emergency mode in question in the PSCad and Visual Basic software.

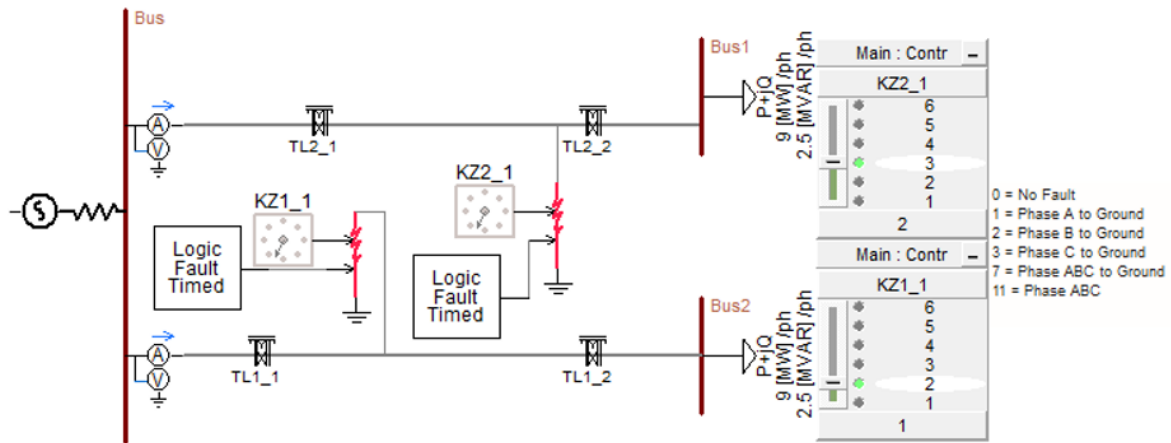

Fig. 2. Simulation modelling of the transmission line 35 kv with a double earth fault on different lines in the PSCad software

The considered scheme has the following parameters:

- voltage of 35 kV network;
- length of the line $L1 = 10$ km, $L2 = 10$ km;
- specific resistance of the phase:

$\underline{z}_L = 0.079 + j0.697$ Ohm / km; - resistivity of mutual induction: $\underline{z}_m = 0.0451 + j0.353$ Ohm / km; - transient resistances in the places of closures are determined by

a random quantity distributed with uniform law in the range from 0 to 10 Ohm;

- load power consumption: $\underline{S}_{Load} = 9 + j2.5$ MBA.

The simulation results were processed in Mathcad and the dependencies of the estimated distances obtained from formulas 1 and 2 were constructed from the actual values (Fig. 3).

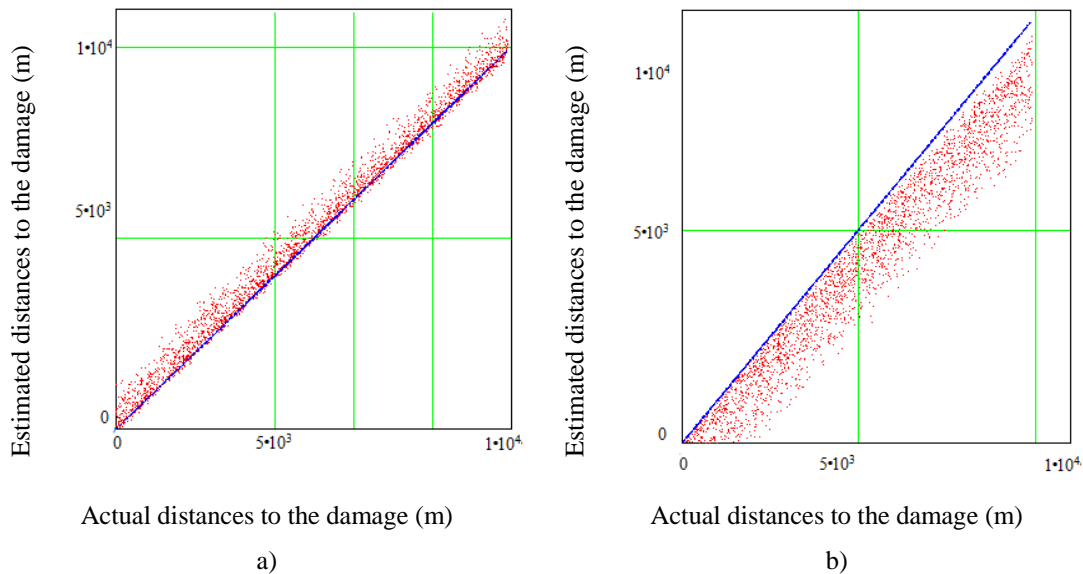

Fig. 3. Dependence of the estimated distances to the damage points of the transmission line on actual ones

Analysis of the obtained results showed that the distance to the first fault point (fig 3a) is determined with a relative error up to 12%, and the mathematical expectation of the obtained error was 3%. The distance to the second fault point (fig 3b) is determined with a relative error up to 26%, and the mathematical expectation of the obtained error was 7%.

Thus, the above method makes it possible to determine the region of double earth fault location for different transmission lines by installing a resistance measuring device connected to the phase current and the phase voltage of the outgoing lines.

3 Fault location rectification applying the iteration recalculation

For increasing in the accuracy of fault location algorithms it is proposed to use the iterative rectification of the calculation results of the distance to the fault. As the initial data, currents and voltages oscillograms in the steady-state short-circuit mode are used, also the values of distances to the faults obtained in the first approximation by formulas (1) and (2).

The algorithm rectifying the distances to the point of the fault on the first power line is below.

Let's find the value of the voltage at the neutral point N1 (Fig. 1), using the parameters of undamaged phase:

$$\underline{U}_{n1} = \left(\underline{U}_{u.ph1} - I_{ph12} \cdot (\underline{Z}_L + \underline{Z}_{Load1}) \right) - (I_{ph13} \cdot \underline{Z}_m + I_{ph11} \cdot \underline{Z}_m \cdot l_{11}), \quad (3)$$

where, $\underline{U}_{u.ph}$ – the voltage of the undamaged phase of the first line; \underline{U}_{n1} – the voltage in the neutral point of the load; I_{ph11} – the current of the damaged phase in

the first transmission line;; I_{ph12}, I_{ph13} – currents of the undamaged phase of the first transmission line; \underline{Z}_L – specific resistance of the transmission line; \underline{Z}_{Load1} – load resistance per phase; l_{11} – distance to the nearest point of damage, obtained by formula (1) regarding the full length of the line.

Consider the damaged phase on the first power line (Fig. 1), taking into account the mutual induction of neighboring phases (Fig. 4).

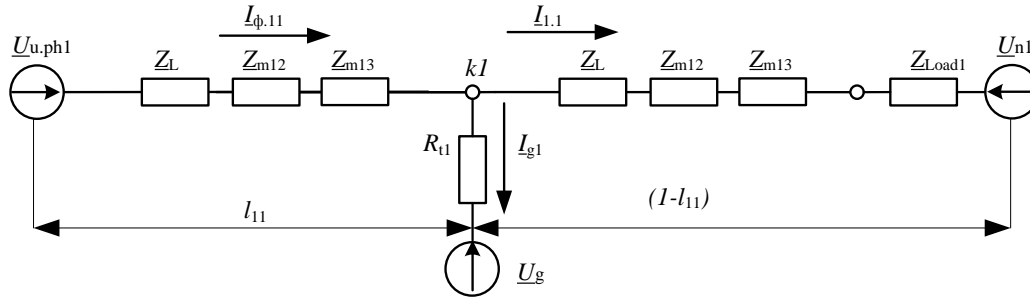

Fig. 4. The replacement scheme of the damaged phase on the first line, with a double earth fault.

Taking into account the fact that the resistance of the equivalent section obtained by Ohm's law is equal to the sum of the resistance of the equivalent circuit, the following expression can be written:

$$\frac{\underline{U}_{u.ph1} - \frac{\frac{\underline{U}_g}{R_{t1}} + \frac{\underline{U}_{n1}}{(1-l_{11}) \cdot (\underline{Z}_L + \underline{Z}_{m12} + \underline{Z}_{m13})}}{\frac{1}{R_{t1}} + \frac{1}{(1-l_{11}) \cdot (\underline{Z}_L + \underline{Z}_{m12} + \underline{Z}_{m13})}}}{I_{ph.11}} = (4)$$

$$= (\underline{Z}_L + \underline{Z}_{m12} + \underline{Z}_{m13})l_{11} + \frac{R_{t1} \left((\underline{Z}_L + \underline{Z}_{m12} + \underline{Z}_{m13}) \cdot (1-l_{11}) + \underline{Z}_{Load1} \right)}{R_{t1} + (\underline{Z}_L + \underline{Z}_{m12} + \underline{Z}_{m13}) \cdot (1-l_{11}) + \underline{Z}_{Load1}}$$

If $\underline{Z}_L + \underline{Z}_{m12} + \underline{Z}_{m13} = \underline{Z}_1$, and ground voltage $\underline{U}_g = 0$, then, taking into account the transformations, the resulting expression looks like this:

$$\frac{\underline{U}_{u.ph1} - \frac{\underline{U}_{n1} \cdot R_{t1}}{(1-l_{11}) \cdot \underline{Z}_1 + R_{t1} + \underline{Z}_{Load1}}}{I_{ph.11}} = (5)$$

$$= \underline{Z}_1 l_{11} + \frac{R_{t1} \cdot (\underline{Z}_1 \cdot (1-l_{11}) + \underline{Z}_{Load1})}{R_{t1} + \underline{Z}_1 \cdot (1-l_{11}) + \underline{Z}_{Load1}}$$

Having expressed R_{t1} from this equation, and taking its absolute value, we obtain a formula for determining the transient resistance:

$$R_{t1} = \left| \frac{\underline{U}_{u.ph1} \cdot (\underline{Z}_1 + \underline{Z}_{Load1} - \underline{Z}_1 \cdot l_{11})}{I_{ph.11} \cdot (\underline{Z}_1 + \underline{Z}_{Load1}) - \underline{U}_{u.ph1} + \underline{U}_{n1}} \right| - \left| \frac{I_{ph.11} \cdot \underline{Z}_1 \cdot l_{11} (\underline{Z}_1 - \underline{Z}_1 \cdot l_{11} + \underline{Z}_{Load1})}{I_{ph.11} \cdot (\underline{Z}_1 + \underline{Z}_{Load1}) - \underline{U}_{u.ph1} + \underline{U}_{n1}} \right| \quad (6)$$

Knowing the value of the transition resistance in the place where the arc arises, it is possible to obtain the value of the current through the transient resistance:

$$I_{g1} = \frac{\underline{U}_{u.ph1} - I_{ph.11} \cdot l_{11} (\underline{Z}_1 + \underline{Z}_{m12} + \underline{Z}_{m13})}{R_{t1}} \quad (7)$$

where $\underline{Z}_{m12} = \underline{Z}_m \cdot \frac{I_{ph12}}{I_{ph11}}$; $\underline{Z}_{m13} = \underline{Z}_m \cdot \frac{I_{ph13}}{I_{ph11}}$ – mutual inductance of the first line regarding the damaged phase; I_{ph11} – the current of the damaged phase on the first line; R_{t1} – transient resistance in the places of the first short circuit.

Then, according to the first Kirchhoff's law, it is possible to determine the supply current of the short-circuit point from the load:

$$I_{1.1} = I_{ph.11} - I_{g1}. \quad (8)$$

Then, taking into account the above, recalculate the voltage at the neutral point N1 (Fig. 1):

$$\underline{U}_{n1} = \left(\underline{U}_{u.ph1} - \underline{Z}_L I_{ph12} - \underline{Z}_{Load1} I_{ph12} \right) - I_{ph13} \underline{Z}_m - \left(I_{ph11} \underline{Z}_m l_{11} - I_{1.1} \underline{Z}_m (1-l_{11}) \right) \quad (9)$$

The solution of the expression (4) regarding to l_{11} allows to determine the distance to the short-circuit point.

The following expression for determining l_{11} can be obtained:

$$l_{11} = \left| \frac{I_{ph.11} \cdot (\underline{Z}_1 + \underline{Z}_{Load1}) + \sqrt{a_1 + b_1 + c_1} + \underline{U}_{u.ph1}}{2 \cdot I_{ph.11} \cdot \underline{Z}_1} \right|$$

$$l_{11} = \left| \frac{I_{ph.11} \cdot (\underline{Z}_1 + \underline{Z}_{Load1}) - \sqrt{a_1 + b_1 + c_1} + \underline{U}_{u.ph1}}{2 \cdot I_{ph.11} \cdot \underline{Z}_1} \right| \quad (10)$$

The coefficients a, b, c formulated from the following expressions:

$$a_1 = (I_{ph.11} \cdot \underline{Z}_{Load1}) \cdot (I_{ph.11} \cdot \underline{Z}_{Load1} + 2I_{ph.11} \cdot \underline{Z}_1 + 4R_{t1} \cdot I_{ph.11} - 2\underline{U}_{u.ph1});$$

$$b_1 = (I_{ph.11} \cdot \underline{Z}_1) \cdot (I_{ph.11} \cdot \underline{Z}_1 + 4R_{t1} \cdot I_{ph.11} - 2\underline{U}_{u.ph1});$$

$$c_1 = 4R_{t1} \cdot I_{ph.11} \cdot (\underline{U}_{n1} - \underline{U}_{u.ph1}) + \underline{U}_{u.ph1}^2.$$

The obtained dependences (expression 10) allow to rectify the distance to the point of damage. To choose

the only correct solution, it is necessary to compare the obtained values of l_{11} with 1 (the values were obtained in p.u. regarding the real length of the line).

On the next iteration, taking into account the new value of the distance to the fault according to the formula (6), the value of the transition resistance is rectified. Onward, according to the expressions (8) and (9), the current of the load-point loading and the voltage at the points N1 are determined. Onward, taking into account the updated values, the distance to the point of damage is determined from expression (10). The iterative process continues until the changes

in the values obtained in two consecutive iterations become insignificant (no more than the required fault distance calculation error).

The distance to the damage point located on the second line is determined similarly.

Verification of the proposed method was tested using the scheme shown in Fig. 2 taking into account the simulation results in the PSCad and Visual Basic.

Figures 5a and 5b show the estimated distances to the nearest and the furthest point of damage on the transmission line dependence on the actual ones.

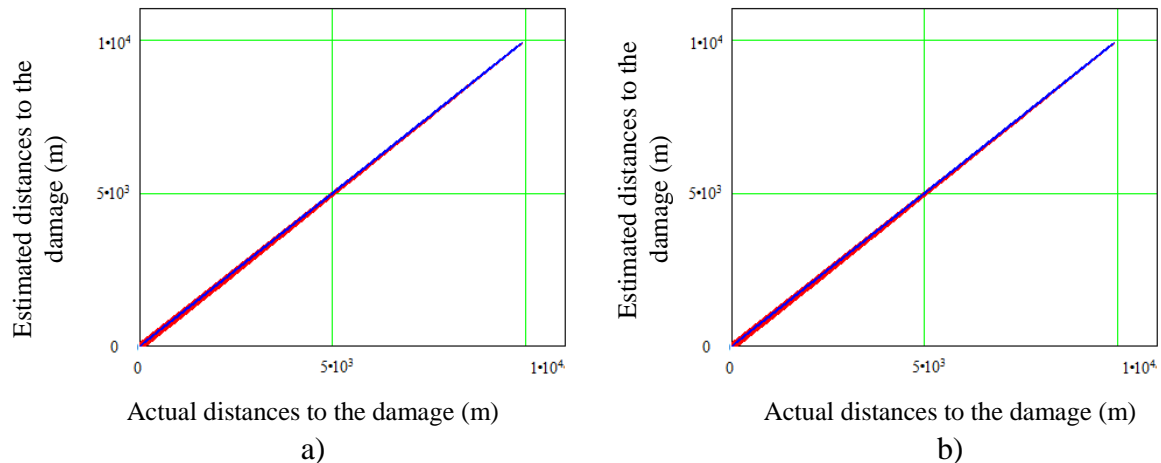

Figure 5. Dependence of the estimated distances to the damage points of the transmission line on actual ones $1 \cdot 10^4$ - $5 \cdot 10^3$ 0

The analysis of figure 5 confirms increasing of the accuracy of the fault location and the reduction of the calculation error in comparison to the initial results. The maximum value of the relative error of the calculation in the near point of damage is 2.2 %, and in the far point of damage 2.3%, which is approximately 38 meters.

4 Formation of the bypass zone under the assumption of the normal law of error distribution of the fault location.

At the core of the organization of the search for the damage location there is the concept of the bypass zone. When solving fault location problems, it is important to determine not only the location of the closure, but also the bypass zone of the line. The size of the zone assesses the period of time required to carry out repair-and-renewal operations [8-10].

Having a sufficiently large amount of statistical data of fault location errors, it is possible to determine the probability density of the error distribution relative

to the estimated damage site and, by specifying the confidence probability, to obtain a confidence interval that will specify the bypass zone of the transmission lines.

In order to form a bypass zone in the case of a double earth fault on different lines, the probability density of the distribution of absolute errors calculation with respect to the estimated fault location was determined for each of the possible fault locations (Fig. 6).

Figure 6a shows the probability density of the absolute error distribution, relative to the estimated value of the distance to the nearest closure point (solid line - before the application of the correction factor, dashed line after it). According to the rule of three sigma (3σ), there was calculated a confidence interval corresponding to the bypass zone. For the point of damage obtained before the application of the iteration recalculation, the bypass area was 1.5 km which is 15% of the total length of the line and after application of the iteration recalculation became 0.2 km which is 2% of the total length of the line.

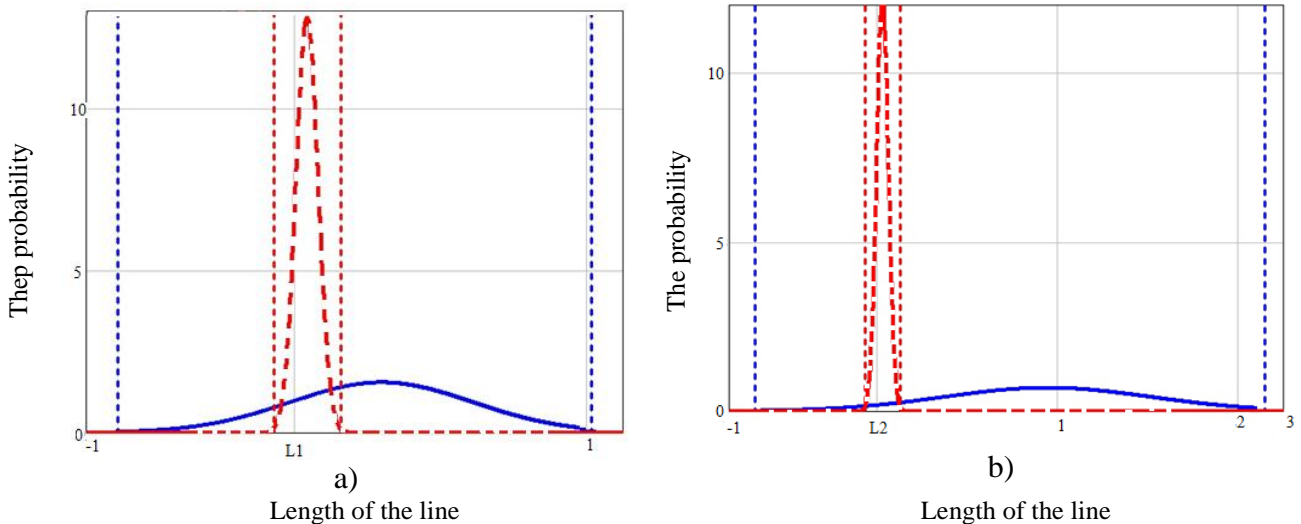

Figure 6 - Example of the probability density distribution of the absolute error relative to the mathematical expectation

The results of bypass zones calculation for the example (Figure 6a) are shown in Table 1.

Table 1. Results of bypass zones calculation for double earth fault on different lines (near point of damage)

	Left border of the bypass zone, km	Right border of the bypass zone, km	Total bypass areas length, km	Total bypass areas length, %
Before the application of iteration recalculation	-0,5	1	1,5	15
After the application of iteration recalculation	-0,06	0,13	0,2	2

The iteration recalculation use clarifying the near point of damage, allowed to reduce the bypass area from 15% to 2% and, therefore, to shorten the time required to eliminate the damage.

Figure 6b shows the probability density distribution of the absolute error, relative to the estimated value of the distance to the far point of closure (solid line - before the application of the correction factor, dashed after it).

For the short circuit point (figure 6b) obtained before the application of the iteration recalculation, the bypass area was 3.5 km - 35% of the total length of the line and after application of the iteration recalculation was 1.3 km - 13% of the total length of the line.

The results of bypass zones calculation for the example (Figure 6b) are shown in Table 2.

Table 2. Results of bypass zones calculation for double earth fault on different lines (far point of damage)

	Left border of the bypass zone, km	Right border of the bypass zone, km	Total bypass areas length, km	Total bypass areas length, %
Before the application of iteration recalculation	-0,8	2,7	35	35
After the application of iteration recalculation	-0,07	0,13	0,2	2

The use of the iteration recalculation to clarify the far point of damage, allowed to reduce the bypass zone from 35% to 2%.

4 Conclusion

It is proposed a method to increase the accuracy of the finding fault location in the case of a double earth fault in a 6-35 kV network using simulation modeling, accumulating statistical information, and error compensation in real calculations based on simulation results. The application of iteration recalculation made it possible to reduce the bypass area of the damaged power line from 15% to 2% for the near point of damage and from 35 to 2% for the long settlement point.

Proposed algorithms provide a significant increase in the accuracy of fault location and a reduction of the damaged bypass zone, as well as cost reduction for the 6-35 kV transmission lines repair-and-renewal operations.

This work was supported by the Ministry of Education and Science of the Russian Federation (agreement No. 14.577.21.0244 for provision of support of September 26, 2017. Unique project identifier RFMEFI57717X0244).

References

- 1 V.G. Glovatskiy, A.G. Khalidov, "Opređenje rasstoyaniya do mest dvoynykh za-mykaniy na zemlyu v elektricheskikh setyakh 35 kV", *Energetik*, vol.9., P.31, 1985.
- 2 E.A.Vorob'eva, D.I. Gandzhaev, G.A. Filatova, V.A. Shuin, "Informatsionnye parametry elektricheskikh velichin perekhod-nogo protsessa dlya opredeleniya mesta zamykaniya na zemlyu v raspredelitel'nykh kabel'nykh setyakh napryazheniem 6-10 kV", *Vestnik IGEU*, vol.2., pp.34-42, 2017.
- 3 E.F. Khakimzyanov, R.G. Mustafin, A.I. Fedotov, "Opređenje rasstoyaniy do mest dvoynykh zamykaniy na zemlyu na linii elektroperedachi raspredelitel'noy seti srednego napryazheniya", *Izvestiya vuzov, Problemy energetiki*, vol.3-4, pp.132-137, 2015.
- 4 A. L. Kulikov, M. Sh. Misrikhanov, A. A. Petrukhin, "Opređenje mest povrezhdeniy LEP 6 – 35 kV metodami aktivnogo zondirovaniya", – M.: Energoatomizdat, P.162, 2009.
- 5 A.N. Visyashchev, "Diagnostika sostoyaniya vozdushnykh liniy elektroperedachi 10-110 kV v normal'-nykh i avariynykh rezhimakh", IrGTU, Uchebnoe posobie, Irkutsk. P. 270, 2012.
- 6 Geoinformatsionnaya sistema OMP 6-35 kV. URL: www.relematika.ru (data obrashcheniya: 17.07.2017) www.relematika.ru/produkty/6-35_kv/sistema_omp_6-35_kv.
- 7 B.V. Papkov "Toki korotkogo zamykaniya v elektricheskikh sistemakh" NGTU , Ucheb. Posobie, P.275, 2005.
- 8 Yu. S. Belyakov, "Aktual'nye vopro-sy opredeleniya mest povrezhdeniya vozdushnykh liniy elektroperedachi", Bibliotekha energetika, prilozhenie k zhurnalu «Energetik», vol. №11.,P.80, 2010.
- 9 A.L. Kulikov, M.D. Obalin, P.A. Kolobanov, "Kompleksnye algo-ritmy OMP LEP na baze statisticheskikh metodov", *Energetik*, vol.№1, 2012.
- 10 A. L. Kulikov, M. D. Obalin, P. A. Kolobanov, "Analiz i povyshenie tochnosti pri opredelenii mesta povrezhdeniya liniy elektroperedachi", *Izvestiya vuzov. Elektromekhanika*, vol. №5, pp.57-62, 2013.
- 11 H. Diaz, M. López, "Fault location techniques for electrical distribution networks: a literature survey," in Proc. the Fifth IASTED International Conference, pp. 311-318, June 15-17, 2005.
- 12 M. Lehtonen, "Novel techniques for fault location in distribution networks," in Proc. Power Quality and Supply Reliability Conference, pp. 1-6, Aug. 27-29, 2008.
- 13 A.L. Kulikov, V.V. Anan'ev, "Adaptivnoe volnovoe opredelenie mesta povrezhdeniya linii ehlektroperedach // Vestnik IGEU, vol.4., pp.21-25,2014.
- 14 V.F Lachugin., D.I. Panfilov, A.N. Smirnov, "Realizatsiya volnovogo metoda opredeleniya mesta povrezhdeniya na liniyakh elektroperedachi s ispol'zovaniem statisticheskikh metodov analiza dannykh", *Izvestiya Rossiyskoy akademii nauk, Energetika*, vol.6, pp.137-146, 2013.
- 15 A.L. Kulikov., M. D. Obalin, V.J. Osokin, T.R. Sharafiev "Primenenie imitacionnogo modelirovaniya LEP 6–35 kV dlya povysheniya tochnosti opredeleniya rasstoyaniya do dvoynykh zamykanij na zemlyu", // Vestnik IGEU, vol.1., pp.40-49,2018.