

Formation of the Z-form of equations of steady-state modes of energy systems' complex electric networks

Dauren Akhmetbayev^{*1}, Arman Akhmetbayev², Assemgul Zhantlessova¹

¹Power Supply Department, S.Seifullin Kazakh Agrotechnical University, Kazakhstan

²Direction of Information Systems of JSC Kaztelecom, Kazakhstan

Abstract. This paper describes the state of the methodological problem of calculating steady-state modes of energy systems' complex electric networks. It also describes the topological method of forming the Z-form of equations of steady-state modes of complex electric networks. The analytical dependence of the node impedance matrix with the matrix of the nodal currents distribution coefficients is established. The matrix of infeed coefficients is determined during the initial data preparation. An analytical approach for determining infeed coefficients topological essence is considered. A simplified method for calculating the driving current distribution coefficients is proposed based on all possible graph trees of a complex electric network. An algorithm for forming infeed coefficients matrix in the environment is developed. A technique for obtaining real solutions of the steady-state mode equations is developed. Steady-state modes direct formation significantly reduces the amount of work performed, increases the visibility of the calculation algorithms performance, and ensures fast and reliable iteration convergence. Increases the level of automation and efficiency of the calculations performed.

1 Introduction

Methodological problems of analysing the electric power system modes are associated with the need to perform a large amount of work on the steady-state modes calculation [1, 2]. In most cases, steady-state modes equations are written in various forms and are nonlinear, which can be solved only by iterative methods [3-5]. Hence, there are many widely used programs for calculating steady-state modes [6-8]. When selecting the most effective of iterative methods, special attention is paid to ensuring and convergence rate of the iterative process.

The conducted studies [9-11] have shown that the difficulties of obtaining real solutions in the steady-state modes calculation can be considerably overcome if we start with inverted form of nodal equations. Complexities in the formation of the inverted form of nodal equations have been overcome to a certain extent by using hybrid matrixes that allow them to combine their advantages by representing them as products of sparsely populated matrixes using various matrix factorization methods. In this paper, the methodology for the formation of the nodal voltages inverted form is developed based on the network topology using the graphs theory.

2 Rearrangement of the state equation

It is sufficient to have all the infeed coefficients and driving currents coefficients to determine the current distributions in the circuit [12]:

$$\underline{i} = \underline{C} \underline{U} \underline{j}, \quad (1)$$

where \underline{j} - driving currents column matrix; \underline{C} - infeed coefficients rectangular matrix.

The values of the currents in the circuit branches remain unchanged if we multiply and divide the right-hand side of equation from the left (1) into the branches resistance matrix, and write in the following form:

$$\underline{i} = \underline{Z}_b^{-1} \underline{Z}_b \underline{C} \underline{j}. \quad (2)$$

On the other hand, the inverted form of the nodal voltages equations has the following form [12]:

$$\underline{U}_\Delta = \underline{Z} \underline{j}, \quad (3)$$

which, taking into account the first Kirchhoff law, can be written in the form:

$$\underline{U}_\Delta = \underline{Z} \underline{M} \underline{i} = \underline{Z} \underline{M} \underline{Z}_b^{-1} \underline{Z}_b \underline{C} \underline{j} = \underline{C}^t \underline{Z}_b \underline{C} \underline{j} \quad (4)$$

The resulting equation (4) is a solution of the equation of nodal voltages and allows us to write the equality in the following form:

$$\underline{Z} = \underline{C}^t \underline{Z}_b \underline{C} = \underline{Y}^{-1}. \quad (5)$$

Thus, the problem of forming an inverted form of nodal equations can be reduced to determining the infeed coefficients matrix.

* Corresponding author: axmetbaev46@mail.ru

3 Infeed coefficients matrix and network topology

The coefficient of the j -node driving current distribution in the i -branch is the ratio defined by the complex number [13]:

$$C_{ij} = \frac{I_i}{J_j} \quad (6)$$

The topology of electric networks makes it possible to establish an analytic relationship between the infeed coefficients and the structure of the straight-line graph [15]. A significant place in the network topology is occupied by such subgraphs as trees and 2-trees. From the values of trees and 2-trees of the graph, numerators and denominators of the driving infeed coefficients of power grids are formed [electric network]. The complexity of searching and singling out the 2-trees of the graph unnecessarily hampered the topological method development in the electric power industry. A new approach for determining the numerators of the infeed coefficients in the function of the network parameters was proposed in [17-19] without searching for and determining the value of the 2-trees of the complex network. Based on all possible trees, specific trees of the oriented graph are formed. The elements of the infeed coefficient matrix are calculated based on the topological expression [17]:

$$C_{ij} = \frac{\sum_{k=1}^M F_{kj}^i}{\sum_{k=1}^N F_k} \quad (7)$$

where $\sum_{k=1}^N F_k$ - the total value of all possible graph trees; $\sum_{k=1}^M F_{kj}^i$ - algebraic sum of the values of the i -branch graph specific trees.

For all infeed coefficients, the denominator is determined once by the total value of the possible graph trees. An algorithm and a program for calculating the infeed coefficients in the Matlab environment have been developed.

4 Formation of Z-form of nodal voltages

Expression (4) allows directly associating the \underline{J} driving currents matrix with \underline{U}_Δ voltages matrix at the nodes with respect to the neutral. After replacing the o.c.p. in branches and transverse branches with the corresponding driving currents, the matrix of voltages at the nodes with respect to the neutral is given by [20]:

$$\underline{U} = U_0 + \underline{C}^t \underline{Z}_b \underline{C} \underline{E}_d^{-1} \underline{S} \quad (8)$$

where \underline{C} - infeed coefficients complex matrix rectangular; \underline{Z}_b - branches resistance diagonal matrix;

\underline{E}_d - nodal conjugate voltages diagonal matrix; \underline{S} - matrix of the column of nodal loads and generators conjugate powers

5 Steady-state mode calculations

The nodal equation (8), after the representation of complex quantities $\underline{S} = P + jQ$; $\underline{C}^t \underline{Z}_b \underline{C} = \underline{Z}$, can be recorded for k -node in the form of [22]:

$$\underline{U}_k = U_0 + \sum_{j=1}^n Z_{kj} \underline{E}_j^{-1} P_j - jQ_j, \quad (9)$$

where $\underline{U}_k = U_k' + jU_k''$.

After separation into real and imaginary parts, equation (1) has the form of:

$$U_k' = U_0 + \sum_{j=1}^n Z_{kj} U_j^{-1} P_j \cos(\delta_k + \psi_{kj}) + Q_k \sin(\delta_k + \psi_{kj}) \quad (10)$$

$$U_k'' = \sum_{j=1}^n Z_{kj} U_j^{-1} P_j \sin(\delta_k + \psi_{kj}) - Q_k \cos(\delta_k + \psi_{kj}), \quad (11)$$

where $U_k = \sqrt{(U_k')^2 + (U_k'')^2}$ - k -node voltage module; $\delta_k = \arctg \frac{U_k''}{U_k'}$ - k -node voltage phase;

$Z_{kj} = \sqrt{(\text{Re} \sum_{j=1}^m C_{kj}^t Z_j C_{jk})^2 + (\text{Im} \sum_{j=1}^m C_{kj}^t Z_j C_{jk})^2}$ - module of mutual nodal resistance;

$\psi_{kj} = \arctg \frac{\text{Im} \sum_{j=1}^m C_{kj}^t Z_j C_{jk}}{\text{Re} \sum_{j=1}^m C_{kj}^t Z_j C_{jk}}$ - phase of complex mutual nodal resistance.

The real and imaginary parts of the nodal voltages are determined by iterative methods, which are accompanied by the definitions of the modules and voltage phases of the nodes. Assigning any generator unit with voltage and active power leads to a partial change in the algorithms for calculating the required variables. Suppose that the parameters of the n -th generating unit are assigned with the active power and voltage. Then the required parameters of the mode of the considered node are the phase of the nodal voltage δ_n and the reactive power Q_n . The value of the reactive power of the n -th node is determined based on [18] and the following expression is valid [22] for the k - iteration:

$$Q_n^k = \frac{U_n^2 \cos \delta_n^{k-1} - U_0 U_n - Z_{nn} P_n \cos(\delta_n^{k-1} + \psi_{nn})}{Z_{nn} \sin(\delta_n^{k-1} + \psi_{nn})} - \sum_{j=1}^{n-1} Z_{nj} U_n U_j^{-1(k-1)} P_j \cos(\delta_j^{k-1} + \psi_{nj}) + Q_j \sin(\delta_j^{k-1} + \psi_{nj}) \quad (12)$$

The imaginary part of the considered node voltage, respectively, is:

$$U_n \sin \delta_n^k = \sum_{j=1}^{n-1} Z_{nj} U_j^{-1(k-1)} \cdot \left(P_j \sin(\delta_j^{k-1} + \psi_{nj}) - Q_j \cos(\delta_j^{k-1} + \psi_{nj}) \right) + Z_{nn} U_n^{-1} \left(P_n \sin(\delta_n^{k-1} + \psi_{nn}) - Q_n \cos(\delta_n^{k-1} + \psi_{nn}) \right) \quad (13)$$

Hence, the value of the nodal voltage phase for the k-iteration has the form of:

$$\delta_n^k = \arcsin \frac{U_n''(k)}{U_n} \quad (14)$$

The essence of the iteration consists in correcting the nodal currents. The line's charging capacities, the corona loss, as well as power transformers no-load losses are taken into account by the corresponding currents, depending on the voltage applied to them, which are refined during the iteration.

Algorithms for the steady-state mode formation are realized in the MATLAB environment. All possible graph trees are defined based on the theory of structural numbers, and specific trees based on algorithm specially developed for this purpose. Block diagram of the algorithms implementation is shown in Figure 1.

In order to provide clarity of the above material, consider a typical example of a 110 kV network (Fig. 2), studied for training purposes in [23], where two generator nodes "0" and "1" operate on a common load in a ring scheme with the following parameters: $Z_1=10+j20$ Ohm; $Z_2=10+j25$ Ohm; $Z_3=15+j30$ Ohm provided that the basic node voltage is $U_0=115$ kV and the corresponding power of $S_1=28,8675+j17,3205$ MVA, $S_2=-46,1880-j23,0940$ MVA.

The total values of the possible graph trees (Fig. 2b) and the specific trees for the first element of the infeed matrix are determined [17, 19]:

$$\Sigma F = Y_1 Y_2 + Y_1 Y_3 + Y_2 Y_3; \quad H_1 = -(Y_1 Y_2 + Y_1 Y_3)$$

The values of infeed coefficient matrix calculated by the program are presented in the form:

$$C = \begin{bmatrix} -0.7299 - 0.0073i & -0.4051 + 0.0109i \\ 0.2701 - 0.0073i & -0.4051 + 0.0109i \\ -0.2701 + 0.0073i & -0.5949 - 0.0109i \end{bmatrix},$$

on which the following generalized network parameters, necessary for calculations are determined:

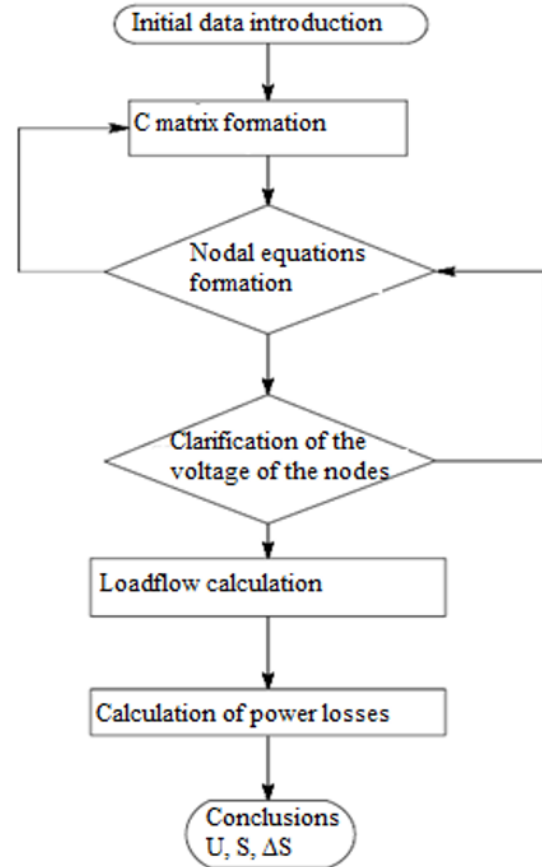

Fig. 1. Steady-state mode formation and calculation block diagram

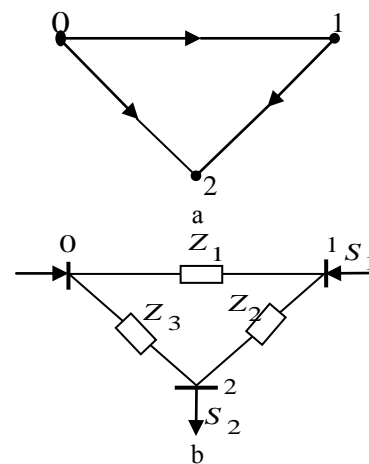

Fig.2 a) Network design scheme; b) Oriented network graph

$$Z_{11} = \sum_{j=1}^3 C_{1j}^t Z_j C_{j1} = C_{11}^t Z_1 C_{11} + C_{12}^t Z_2 C_{21} + C_{13}^t Z_3 C_{31} = 16,3223; \varphi_{11} = 64,0079;$$

$$Z_{12} = Z_{21} = \sum_{j=1}^3 C_{1j}^t Z_j C_{j2} = C_{11}^t Z_1 C_{12} + C_{12}^t Z_2 C_{22} + C_{13}^t Z_3 C_{32} = 9,0618; \varphi_{12} = 61,9;$$

$$Z_{22} = \sum_{j=1}^3 C_{2j}^t Z_j C_{j2} = C_{21}^t Z_1 C_{12} + C_{22}^t Z_2 C_{22} + C_{23}^t Z_3 C_{32} = 20,0292; \varphi_{22} = 64,49.$$

Based on equations (10), (11) and (12), (13), calculations for a given network were made twice, when the first node is assigned with active and reactive powers, and when the same node is assigned with voltage and active power. The calculations are performed by a simple iteration method with accuracy and the results of which are given in Tables 1, 2.

Table 1. Results of the calculation of the network mode in Fig. 6a, when the nodes are assigned with active and reactive powers

Iteration index	0	1	2	3	4	5
U_1' , kV	-	115,7126	115,4016	115,4105	115,4096	115,4096
U_1'' , kV	-	0,2703	0,2847	0,2777	0,2783	0,2782
U_1 , kV	110	115,7129	115,4020	115,4108	115,4100	115,4100
δ_1 , grade	0	0,1338	0,1414	0,1379	0,1382	0,1381
U_2' , kV	-	109,8411	109,6159	109,6140	109,6123	109,6123
U_2'' , kV	-	-4,4186	-4,1153	-4,1479	-4,1456	-4,1459
U_2 , kV	110	109,9300	109,6931	109,6924	109,6907	109,6907
δ_2 , grade	0	-2,3036	-2,1500	-2,16071	-2,1660	-2,1661

Calculations results show that the developed algorithm of calculation, at assigning the node with voltage and active power provides convergence of the established mode at the fifth step of iteration process, at accuracy of $10^{-5}U_i$. It is known from [23] that the Newton method ensures the convergence of the steady-state mode at the accuracy of $10^{-3}U_i$, at the fifth step of the iteration, whereas the simple iteration on the proposed algorithm, the steady-state mode of the same electric network, also converges at the fifth iteration, but at calculation with accuracy of $10^{-5}U_i$.

Table 2. The results of the calculation of the network mode in Fig. 6a, with the generator node assigned with voltage $U_1 = 115,4100$ kV and the active power $P_1 = 28,8675$ MW.

Iteration index	0	1	2	3	4	5
Q_1 , MVA _{ap}	-	16,4542	17,2586	17,2480	17,2804	17,2805
U_1' , kV	-	0,1903	0,2848	0,2745	0,2749	0,2749
δ_1 , grade	0	0,0945	0,1414	0,1363	0,1365	0,1365
U_2' , kV	-	109,8151	109,6101	109,6416	109,6405	109,6406
U_2'' , kV	-	-4,3641	-4,0988	-4,1269	-4,1249	-4,1251
U_2 , kV	110	109,9018	109,7167	109,7192	109,7181	109,7181
δ_2 , grade	0	-2,2758	-2,1410	-2,1556	-2,1546	-2,1547

This reveals the advantage of the proposed method. To estimate the accuracy, the results of the fifth iteration of the steady-state mode from [23] is presented:

$U_1=115,4150$ kV, $\delta_1=0,1352$ grade., $U_2=109,7210$ kV., $\delta_2=-2,1553$ grade, which, as can be seen from Table 3, differ within the rounding error. Therefore, the proposed method can be used both in scientific studies and in the performance of operational calculations of steady-state modes of electric power systems.

6 Conclusions

1. A topological algorithm for the search and calculation of specific trees for a directed graph of a complex electric network was developed.
2. A topological method for the formation of the complex network steady-state mode in the MathLab environment was developed.
3. Calculations of modes of complex networks do not experience any difficulties when changing the form of the task of generating units.
4. The proposed method increases the degree of automation of the ADMS tasks.

References

1. Venikov V.A. Modeling of large systems of electric power industry. Electricity, No. 5, 64-67 (1978)
2. Venikov VA, Golovitsyn BI, Liseev MS, Unarovok AA Calculation of the EPS regime based on telemetry data based on the regularization method // Izvestiya / Energy and transport., No. 2, 39-49 (1976)
3. Barinov VA, Sovalov SA Regimes of power systems: Methods of analysis and control, Moscow: Energoatomizdat, 440 (1990)
4. Stroyev VA, Rokotyay IS Methods of mathematical optimization in power supply problems, M.: MEI, 72 (1993)

5. Khachatryan V.S. Method and algorithm for calculating the steady-state regimes of large power systems. *Izvestiya / Energy and transport.*, No. 4, 45-57. (1973)
6. Geraskin O.T. Diakoptics and sparsity of tasks and calculations of large electric energy systems. *News of higher educational institutions of the USSR. Power engineering.* No.1. 7-12 (1982).
7. Idelchik V.I. Calculations and optimization of modes of electric grid of power systems, Moscow. *Energia*, 190 (1977)
8. Gursky S.K. Algorithmization of problems of control of modes of complex systems in the electric power industry. *Minsk, Science and Technology*, 367 (1977)
9. A computer in energy problems. *TIER, Moscow, Mir.* T.62, 239 (1974)
10. Smirnov K.A. On the convergence of iterative solutions of the steady-state regime of the electric power system for given power of nodes // *Izvestiya / Energy and transport.*, No. 3, 120-129 (1975)
11. Manusov BZ, Lykin AV, Sidorkin Yu.M. Algorithms of the Newton-Raphson method for solving nodal equations in inverted form // *Izvestiya / Energy and transport.*, No. 9, 3-7 (1974)
12. H.F. Fazylov, T.X. Nasyrov. Established regimes of electric power systems and their optimization. *Lightning.* 370 (1999)
13. NA Melnikov. A mathematical method for analyzing electrical circuits. 232 (1972)
14. Melnikov N.A. The application of the distribution coefficients in the calculation of complex circuits for the replacement of electrical circuits. *Electricity*, No. 2, 9-13 (1961)
15. Geraskin O.T. Application of the theory of signal graphs to the calculation of the current distribution coefficients in electrical networks. *Izvestiya / Energy and transport.*, No. 5, 33-39 (1965)
16. Geraskin O.T. Methods for the determination of 2 - graph trees in the topology of electrical networks. *Izvestiya / Energy and transport.*, No. 5, 106-112 (1967)
17. Dauren S. Akhmetbayev, Daurenbek A. Aubakir, Yermek Zh. Sarsikeyev, Bakhtybek A. Bainiyazov, Mikhail A. Surkov, Vitaliy I. Rozhkov, Gulbahit N. Ansabekova, Assel S. Yerbolova, Azamat T. Suleimenov, Miramgul S. Tokasheva. Development Of Topological Method For Calculating Current Distribution Coefficients In Complex Power Networks, *Results in Physics*, 7, 1644-1649 (2017)
18. Akhmetbayev D. Method of calculating the steady-state modes of electrical networks based on the current distribution coefficients. *Electricity*, No. 11, 23-27, (2010)
19. Dauren Akhmetbayev, Arman Akhmetbayev, Azamat Suleymenov, Michal Kolcun. Modeling the Set Mode of Complex Power Grid, Based on Infeed Coefficients. *Proceedings of the 9th International Scientific Symposium, Stará Lesná, Slovak Republic, ELEKTROENERGETIKA*, 12.-14, 9 (2017)
20. Akhmetbayev D., Akhmetbayev A., Aidarova A. Determination of the rational transformations distribution networks distribution. *E3S Web of conferences* 25.04003 (2018).
21. Arman Akhmetbayev, Dauren Akhmetbayev, Serik Zhumazhanov, Bauyrzhan Zhakishiev. New Modeling of Steady-State Modes of Complex Electrical Grids of Power Systems *MATEC Web of Conferences* 155, 01043 (2018).
22. Akhmetbayev D., Akhmetbaev A., Berdygozhin A.S. Topological method for the formation of an inverted form of the node equations of electric energy systems. *Electricity*, No. 5, (2018)
23. Yu.N. Astakhov, V.A. Venikov, V.V. Ezhov, N.I. Zelenokhat, E.N. Zuev, V. Idelchik. I.V. Litkens, S.V. Nadezhdin, E.V. Putyatin, Yu.P. Ryzhov, V.A. Stroev. *Electric power systems in examples and illustrations.* Edited by V.A. Venikova, *Energ atomizdat*, 504 (1983)