

Residential electricity saving on a DC-coupled hybrid microgrid by the real-time simulation

Yu-Jen Liu*¹, Gary W. Chang¹, and Yi-Feng Pai¹

¹Department of Electrical Engineering, National Chung Cheng University, Chiayi, Taiwan (R.O.C.)

Abstract. In this paper, a DC-coupled hybrid microgrid is investigated and a simulation-based electricity analysis manner by using the OPAL-RT real-time simulation is developed for the discussion of the energy-saving issue on the microgrid. Methodologies include modelling, simulation mechanism, and the development of control strategies are presented, and two different electricity price rules are introduced to calculate the residential electricity that from the investigated microgrid based on the designed scenarios. Results show that the benefit of electricity saving provided by the operation of the microgrid system are reported.

1 Introduction

Microgrid (MG) is proposed as an application for designing and operating the electric grid so as to achieve a more sustainable and cost-effective energy system while generally providing alternative-energy sources-driven power supply for grid end-users' load demands. Electricity users/consumers have higher expectancies to seek reliable and lower costs electricity. Thus, let the increasing of using localized energies with the MG solutions is considered can reach this goal. Electricity in a MG system can be collected by different locations, like utility grid, end-user, and the output of energy system in MG. In past, some of electricity analysis efforts have been proposed by using time-series simulation tools with simplified (or phasor-type) models [1] [2]. Furthermore, various means such as using energy-saving lights and inverter-based electric appliances have also been introduced for electricity saving. To understand the electricity response in a MG system, this paper aims to develop a simulation-based electricity analysis environment by integrating different simulation packages and analysis methodologies; meanwhile, assumed load peak shaving scenario is used for the simulations of residential electricity. Overall, proposed methodologies may be helpful for user demand management and system operation control in MG applications.

The rest of this paper is organized as follows. Section 2 describes the system configuration of studied microgrid system and major model characteristics. Section 3 illustrates the various used control strategies and proposed real-time simulation mechanism. Section 4 presents the simulation results from using different case scenarios in this work, and conclusions are given in Section 5.

* Corresponding author: azenliu@ccu.edu.tw

2 System configuration and modelling

The term “hybrid AC/DC microgrid” refers to a MG system that includes both AC and DC energy sources and loads. Leans on how the energy sources and loads are connected to the MG system and how the AC and DC buses are set up, the hybrid AC/DC MGs are generally classified into AC-coupled, DC-coupled and AC-DC-coupled types [3], and this paper focus on the investigation of DC-coupled one. Following gives the presentation of system configuration and modelling methodologies.

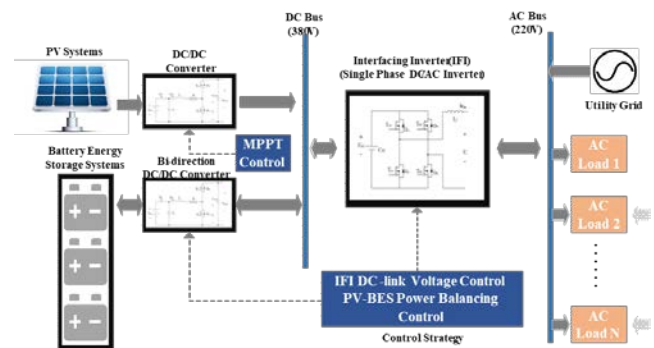

Fig. 1. Configuration of a DC-coupled hybrid microgrid.

2.1 System Configuration

Figure 1 shows a DC-coupled hybrid MG that be investigated in the study, where photovoltaic (PV) generations, include a boost-type DC/DC converter, and battery energy storage (BES) systems, with a bi-direction DC/DC converter, are main alternative energy sources that connected to the common a 380 V DC bus. A single-phase interfacing DC/AC inverter (IFI) that provide bi-directional power flow capability is used to link the DC bus and 220 V

AC bus. Furthermore, when multi-IFIs are suited, according to the requirement on power exchange between DC and AC buses, parallel construction of IFIs may be used in order to increase the system rating and reliability. General residential AC loads or variable frequency AC loads can be connected to AC and DC bus, respectively. This structure can be used when DC power sources are major power generations beside utility in the MG, and it is note that if any other alternative energy sources are on AC bus, it considered as a different type of MG in study.

2.2 Modelling

MATLAB/Simulink is implemented for modelling and simulation tasks in this study. Completed MG system model is developed in Fig. 2; meanwhile, detailed model for each main electrical component is used in simulations to effectively present the dynamic properties on the consumptions of the MG end-users electricity. Major models are as follows:

- PV power generations are built by single-diode equivalent circuits that describe the v-i characteristic of the PV arrays and the boost type DC/DC converters are used to raise the output voltages from PV arrays.

Maximum power point tracking (MPPT) control adopts perturb and observe method [4].

- Lead-acid type generic battery model built-in MATLAB/Simulink is used as the BES [5]. Model parameters like nominal voltage, rated capacity and initial state of charge (SOC) etc. are required for the model inputs. The voltage of lead-acid BES nonlinearly decreases with SOC rate as the battery in discharging state; furthermore, lead-acid BES can easily be recharged if the discharge current gives reverse flows in battery model. Temperature effects in battery model are ignored, and it is assumed that the SOC rate of the battery varies with changes in voltage and charging/discharging currents. A non-isolated bi-direction DC/DC converter model is built in charge of achieve a bi-directional power transformation between the DC bus and the battery [6].

- Main end-users in MG system are general single-phase low-voltage residential users. Single-phase full-bridge DC/AC voltage source inverter is modelled to provide AC power supply to each behind end-user [7].

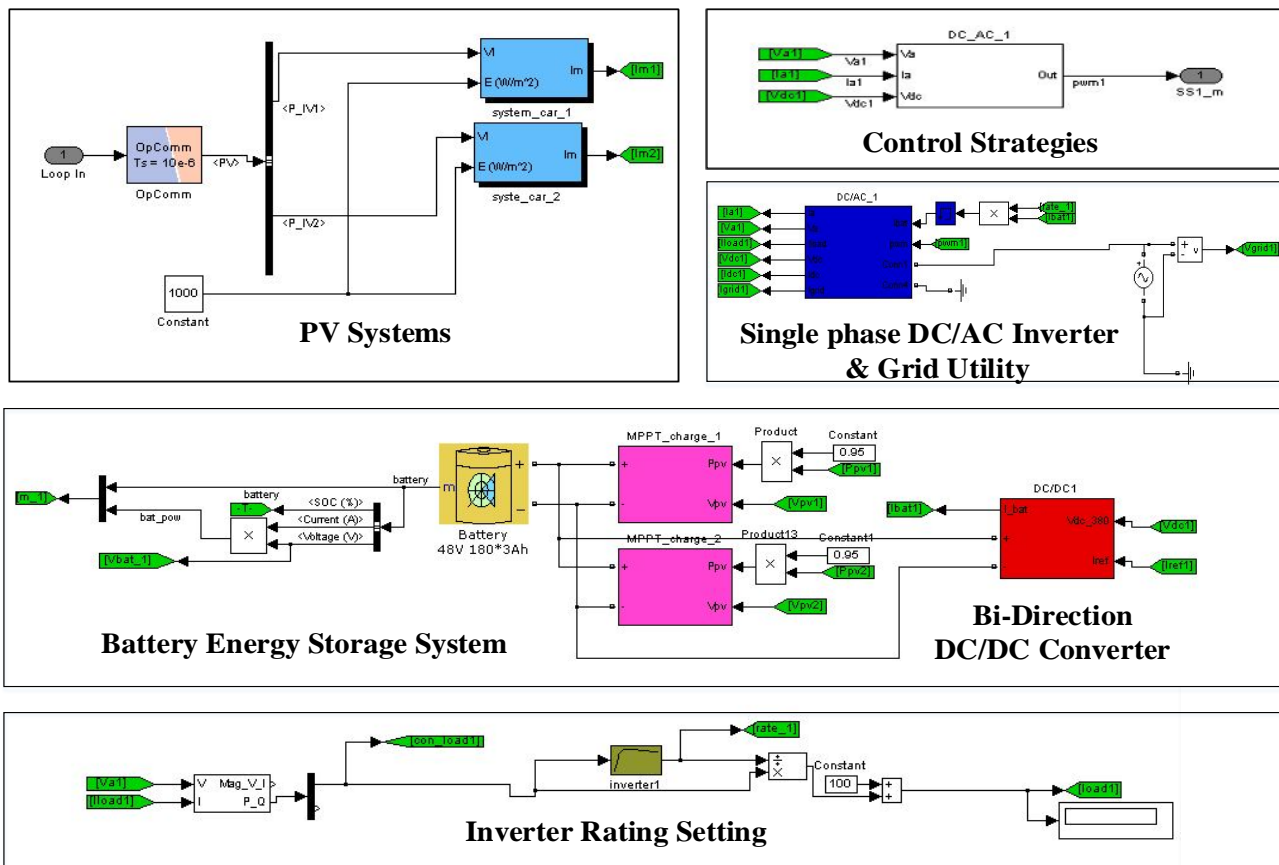

Fig. 2. Configuration of a DC-coupled hybrid microgrid model.

3 Control strategy and simulation mechanism

To carry out the electricity analysis of end-users in MG, used control strategies and simulation mechanism, following gives a summary:

3.1 Control Strategy

For the DC-coupled hybrid MG operates in either grid-connected or stand-alone modes, the major control and power management objectives are DC-link voltage control, power balancing management between power generations and load demands, and the voltage and frequency controls in AC bus; but, only the MG system operates in grid-connected mode with the un-dispatched power output is investigated in this study. For this operation scenario, let IFI works on DC-link voltage control mode and achieves the control on DC-link voltage. Then adjusts the DC-link voltage to desired values [8]; the PV system should work on a MPPT control state; a constant current control on bi-direction DC/DC converter is required for charging and discharging BESs [9]; and power balancing between all power generations and loads are carried out by [10][11].

3.2 Simulation Mechanism

OPAL-RT real-time simulation (RTS) technology is adopted in this study for electricity time-series simulations, as shown in Fig. 3 [12]. In RTS environment, the Host side and Target side are two major parts. In the former, a commercial Intel four cores 3.30 GHz CPUs and 8.0 GB RAM personal computer (PC) is used; and in the latter, the OP5600 HIL box with two Intel Xeon six cores 3.46 GHz CPUs and 4.0 GB RAM is used and five cluster nodes (CPU cores) are used as well for parallel simulations. Completed MG model in Fig. 2 that relates to the configuration in Fig.1 is separated as five subsystem models and via a C-code compilation process by Real-Time Workshop (RTW) to let the computation tasks of these models on assigned CPU units. Data exchange between different CPUs is done though the shared memory technique used in PC motherboard that has ultra-low latency property and thus allows the parallel simulation of electric power systems at a small time-step size. The Ethernet protocol with a hundred-Mbps data rate is established to carry out the communication and data conversion between the Host and the Target sides. The operation systems for Host and Target sides are Windows 7.0 and Redhat, respectively. An interfacing software RT-LAB, which builds parallel tasks from the original MATLAB models and runs them on each CPU of the OP5600 HIL box is also required.

Overall, time-series analysis procedures in the study are as follows:

- Step 1: to prepare required input data include assumed system parameters (like grid topology, line impedances, and transformers' parameters), daily solar irradiance, and initial battery setting as model inputs.
- Step 2: to determine the required solar power generation and required battery capacity based on real operation experiences or assumed data and proposed control strategy.
- Step 3: to collect load profiles from actual metering infrastructures or assumed data then as end-users load model.
- Step 4: to run general simulations in RTS environment and then results of electricity analysis can be produced.
- Step5: repeat the procedures from Step 2 to Step 4 and sets various data/parameters for estimating the performances of the MG system on different test scenarios.

4 Case study

According to the MG system configuration in Fig. 1, simulations for the residential electricity among the MG are implemented. Simulations use about 15 kW PV system, 1.96 kWh BESs, load profile in Fig. 4(a), collected from a single-phase 110V/60Hz AC residential end-user with a 80 kWh consumed electricity in summer days, and real solar irradiance in Fig. 4(b). Results from the cases with/without the peak shaving implementations are observed.

4.1 Without Peaking Shaving

Figure 5 shows the simulation results for the residential user with a general operation of MG i.e. no peak shaving is implemented. It means the residential end-user can only accept electricity supply from the MG during the significant solar irradiance and BES storages periods (i.e. 8:00 AM to about 21:00 PM). In this case, about 40.4 kWh electricity is supplied by the MG and reminder about 39.6 kWh electricity is provided by the utility grid.

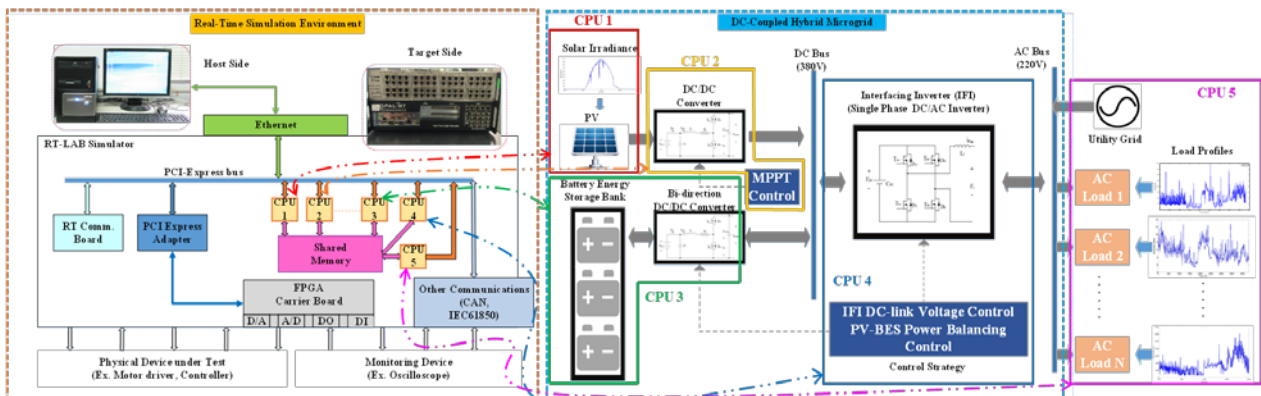
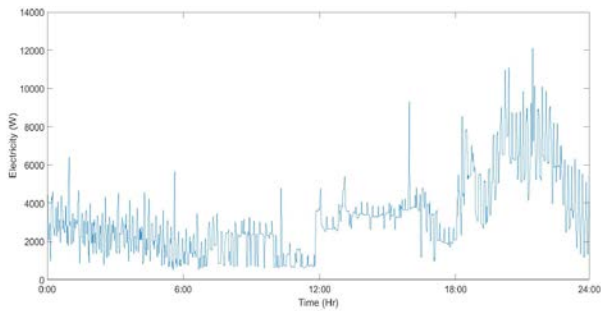
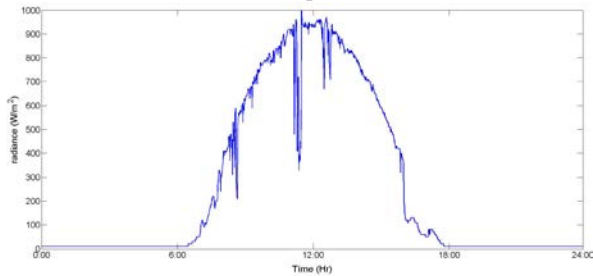

Fig. 3. Configuration of a DC-coupled hybrid MG in real-time simulation environment.



(a) Load profile



(b) Solar irradiance

Fig. 4. Input data in simulations.

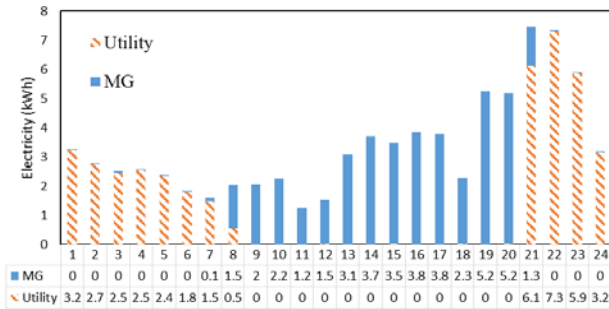

Fig. 5. Simulation results-without peak shaving

4.2 With 20 % Peaking Shaving

In order to understand the differences if implements any energy-saving manners in end-user can get a better benefit on electricity saving, a manual peak shaving is performed. To observe Fig. 4(a) used load profile, Peak hour time of the residential end-user presents at about 19:00 PM to 23:00 PM. Therefore, an assumed 20 % electricity collected from 19:00 PM to 22:00 PM is transferred to high solar irradiance durations (here is time from 11:00 AM to 14:00 PM) in this case. Then the results of electricity analysis is given in Fig. 6. It is found that required electricity supply from utility grid can be slightly reduced from 39.6 kWh in Case 1 to 36.2 kWh in this case.

4.3 With 60 % Peaking Shaving

Using the same time periods in Case 2 but an assumed 60 % electricity is transferred in this case. From the results in Fig. 7, more end-user electricity can be supplied by the MG when compare to the previous two cases and power supply by utility grid in this case reduces to about 29.5 kWh.

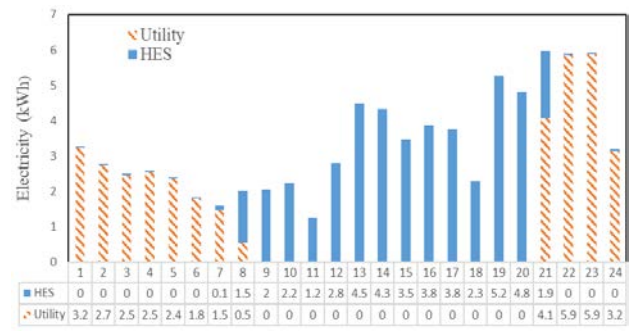

Fig. 6. Simulation results-with 20% peak shaving

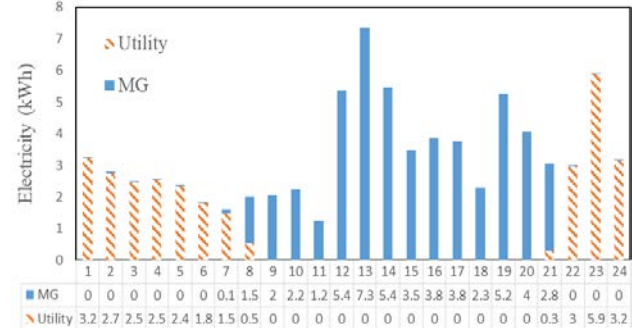

Fig. 7. Simulation results-with 60% peak shaving

4.4 Analysis of Electricity Price from Simulation Results

There are two electricity price rules, general electricity price (GEP) and time-of-use electricity price (TOUEP), used to calculate the total electricity bill for the residential end-user in previous cases. Table I shows the prices for GEP, different prices are given among different electricity used segments then the electricity bill is calculated by the equation presented in Note 2 of Table I. TOUEP in Table II, two time-segments mechanism, i.e. peak time and off-peak time, is used in the study, and the prices are different on weekdays and weekend days. For weekdays, 4.44 \$/NTD/kWh and 1.80 \$/NTD/kWh are used for peak time and off-peak time, respectively; for weekend days, single price of 1.80 \$/NTD/kWh is used for whole day electricity; and a price of 0.96 \$/NTD/kWh is required for the part of total used electricity exceed 2000 kWh. Finally, a base cost of 75 \$/NTD per month must be included for an electricity bill. Equation presented in Note 3 of Table II can be used for TOUEP. Results of the calculations on total electricity prices are summarized in Table III.

Table 1. General electricity price for summer season.

Used electricity (kwh)	Price (\$/NTD/kWh)
<120	1.63
121~330	2.38
331~500	3.52
501~700	4.80
701~1000	5.66
>1001	6.41

Note:

¹. Supposes there are no losses in load demands and daily used electricity of these 2 months is all the same here. Thus let 2 months (62 days) electricity to be one bill.

* Corresponding author: azenliu@ccu.edu.tw

$$^2 \text{ Calculation of electricity fee:}$$

$$\text{Total bill} = \{[(120) \times 1.63] + [(330 - 120) \times 2.38] + [(500 - 330) \times 3.52] + [(700 - 500) \times 4.80] + [(1000 - 700) \times 5.66] + [(\text{total used electricity}_{\text{per bill}} - 1000) \times 6.41]\} \times 2$$

Table 2. Two-segment time-of-use electricity price for summer season.

Monday to Friday (Weekdays)		Sat. to Sun. (Weekend days)
Peak time (\$NTD/kWh)	Off-peak time (\$NTD/kWh)	All day (\$NTD/kWh)
4.44	1.80	1.80

Note:

1. Supposes there are no losses in load demands, one bill includes 2 months; meanwhile, it supposes there are 46 weekdays and 16 weekend days of electricity consumptions. Also supposes daily used electricity in these 2 months is all the same here.

2. A base cost of 75 \$NTD per month is required.

3. Calculation of electricity bill:

$$\text{Total bill} = \{75 + [(\text{total peak time electricity per day}(\text{weekdays}) \times 4.44) + (\text{total off peak electricity per day}(\text{weekdays}) \times 1.80)] \times (\text{weekdays}) + [\text{weekend days} \times \text{total electricity per day}(\text{weekend days}) \times 1.80] + (\text{total used electricity per bill} - 2000) \times 0.96\} \times 2$$

Table 3. Calculation of total electricity price from simulation results.

Items	Electricity Price (\$ NTD)	
	General Price (Summer Season)	Time-of-Use Price (Summer Season)
Without peak shaving	10,896	6,404
With 20% peak shaving	9,497	5,462
With 60% peak shaving	7,904	3,846

It is found that for the end-user in the MG without implements energy-saving means, a higher electricity price, 10,896 \$NTD for GEP and 6,404 \$NTD for TOUEP, separately, should be paid. However, it is apparent that a saving on the electricity price can be met when peak shaving is implemented; for example, total electricity price reduces to 9,497 \$NTD. The comparisons of the electricity prices from different price rules can be found as well.

5 Conclusion

Understanding the use of electricity among different energy sources in a microgrid can be helpful for end-users on demand energy management. The major purpose of this paper is to present an effective simulation-based environment by implements MATLAB/Simulink for the electricity analysis in a DC-coupled hybrid microgrid system. Modelling methodology, simulation mechanism, and control strategies used in this study are discussed. Performances

of the studied system are also validated by the designed simulation cases. Investigations of above-mentioned results are mainly focused on the single microgrid and single end-user configuration. Simulation models can be flexibly extended to comply with different requirements when meets various system topologies. Other future works of this paper are thus expected to integrate the functionalities of energy/load prediction and energy sources optimization, and to build energy management human machine implementations and applications on microgrid operation, planning, and demand-side management issues.

References

1. C. Sandels, *Ph.D. dissertation*, KTH Royal Institute of Technology, (Stockholm, 2015).
2. J. Bajada, M. Fox, and D. Long, *Proceedings IEEE ISGT Europe* (2013).
3. E. Unamuno and J. A. Barrena, *Renewable and Sustainable Energy Reviews* (2015).
4. M. G. Villalva, J. R. Gazoli, and R. Filho, *IEEE Trans. on Power Electronics* (2009).
5. K. K. Sibi, P. Prasanth, R. Sunitha, *Proceedings IEEE ICPS* (2016).
6. H. Hu, X. Cheng, J. Wang, and X. Zou, *Proceedings* (2017).
7. W. Xiao, *Photovoltaic power system: modeling, design, and control*, (John Wiley & Sons Ltd, NJ, 2017).
8. D. Chen and L. Xu, *IEEE Trans. on Power Systems*, (2012).
9. WECC Renewable Energy Modeling Task Force, (Salt Lake City, 2016).
10. X. Liu, P. Wang, and P. C. Loh, *IEEE Trans. on Smart Grid* (2011).
11. Y. J. Liu, S. I. Chen, Y. R. Chang, and Y. D. Lee, *Appl. Sci.* (2017).
12. S. Mikkili, A. K. Panda, and J. Prattipati, *J. of the Ins. of Eng. (India): Series B* (2015).