

Development and installation of control system for a test rig interconnecting a micro Gas Turbine, a Heat Pump and a PCM Storage system

Iacopo Rossi^{1,*}, *Romain Caillere*²

¹University of Genoa, 16145, Genoa (Italy)

²France

Abstract. The need to enhance flexibility on current power plant is linked to the strong penetration of non-dispatchable sources in the current energy network, which causes a dramatic need for ancillary services to sustain the grid operability. A framework including a micro Gas Turbine (mGT), a Heat Pump (HP) and a PCM Storage is considered to enhance plant flexibility while facing grid and price fluctuations during day operations. The system so composed is devoted to electrical energy production only. A proper use of the HP allows, for instance, to heat up the compressor intake temperature whilst the system is operating at minimum load. The system can then produce a lower amount of energy in order to be more competitive in the infra-day energy market. At the same time, the cold storage is charged and the stored energy can be later used to power up the system during the peak hours by cooling the compressor intake. This work presents then the installation of the control system devoted to the management and the control of such complex system. The test-bed is defined to test different operating conditions and to validate the operating framework of the whole compound.

1 Introduction

The panorama of gas turbine combined cycle is going to come into a deep renovation and re-directed towards new operative scenarios as renewables are changing dramatically the production system. Particularly in Europe, combined cycles fed by natural gas are considered to drive the energy transition since they are capable to sustain the grid and the resiliency of the whole production system with the lower emissions impact among the fossil-fuelled systems [1]. Moreover, gas turbines are considered to be determinant in providing energy with fuel obtained from power excess, in a power-to-x-to-power framework [2]. The perspective for the near future is a strongly connected framework where a horizontal generation and usage hierarchy place each player at the same level. The awaited new explosion of renewables, after the first disruptive penetration at the beginning of '10, will now replace most of the current systems based on carbon and other pollutant fossil fuel. The existing combined cycles will however undergo severe upgrades in order to improve their flexibility in terms of ramps and start up – in order to better assist the grid sustainability – as

* Corresponding author: iacopo.rossi@edu.unige.it

well as in terms of fuel flexibility. This paper focuses on the flexibility of combined power plants via a retrofitting of existing systems with a heat pump and coupling with advanced control system. When it comes to consider innovative control system for normal operating condition of combined cycle, these are rather hard to find in literature – where focused is placed on start-ups. In this integrated layout is however necessary to have a management system capable to decide with a 15 minutes resolution as well as 1 second resolution which will be the best configuration of the system, which is the usage of the heat pump and when it is better to charge/discharge the storage. This paper introduces the control system and its implementation in the environment.

2 PUMP-HEAT Project

The H2020 PUMP-HEAT project (Performance Untapped Modulation for Power and Heat via Energy Accumulation Technologies) aims to increase the flexibility of the Combined Cycle power plants in the current energy market, hungry for plant flexibility. Since the combined cycle power plants are considered the mean to drive the current production system to a new framework based on renewables sources, the interest of improving further their flexibility is strong for existing power plant as well as new foreseen installation. Considering the European continent, new investments and plants are forecast particularly for the eastern side. New investments and plans are also expected to cover the doubling of gas fired generation expected within 2035. According to all these issues, the foreseen NG based power capacity in 2030 will be around 230 GW starting from the current capacity of 191 GW. The integrated system proposed in this project features thermal storage and advanced control concept for smart scheduling. The main advantages that such integrated system aims to achieve are listed [3]:

- the HP is controlled to modulate power in order to cope with the CC primary reserve market constraints;
- the high temperature heat can be exploited in the district heating network, when available; low temperature cooling power can be used for gas turbine inlet cooling or for steam condenser cooling, thus reducing the water consumption;
- in both options, the original CC operational envelope is significantly expanded and additional power flexibility is achieved.

Considering the economic viewpoint, the performance offered by the PUMP-HEAT framework can achieve an annual and seasonal efficiency increase up to 5%, whilst reducing OPEX of 3%. Furthermore, the possibility for such plants to sell more electricity on the Regulation and Ancillary Services Electrical Market, thanks to their increased flexibility and fast responsivity is increased. At the same time the number of start-ups is reduced by 5-10% and the related extra costs, equivalent operating hours (EOH) and wear [3]. The target power plants for the application of the PUMP-HEAT system are the IREN Moncalieri 2GT 400MW and the Combined Cycle emulator of the laboratory of the University of Genoa, based on a Turbec T100 – a 100kW micro gas turbine.

3 Control Structure and Signals

The control problem has been already presented in general way in [4] and it has been discussed for a similar layout in [5]. The control problem is about controlling in real time the heat pump accordingly to the energy sold the day ahead. In the current framework the uncertainties linked to energy forecast and production are linked to many variables. Since it is not possible to intervene on the power plant operating in the zones, which may cause unbalances in the same nodes the power plant is insisting, some precautions can be obtained by sustaining the power plant production in according to the amount of energy sold the they ahead. In this case, the deviation from the energy production sold on the market is principally linked to errors in ambient temperature previsions. Deviations under this aspect may cause differences at maximum load as well as minimum load. A dynamic control on the inlet can be used to minimize these deviations. Nevertheless the proposed system is mostly useful to allow the system to sell better performance on the market. Indeed the capability to set the power to higher level when it comes to sell energy conveniently i.e. at maximum power, whilst it is of interest to determine when the power must be reduced and to control this process. The control process is therefore focused at the auxiliary power level i.e. the heat pump and the TES. These must be used to determine which must be the correct/better solution in terms of operating system and to better track the energy sold – therefore to assist the combined cycle in energy production.

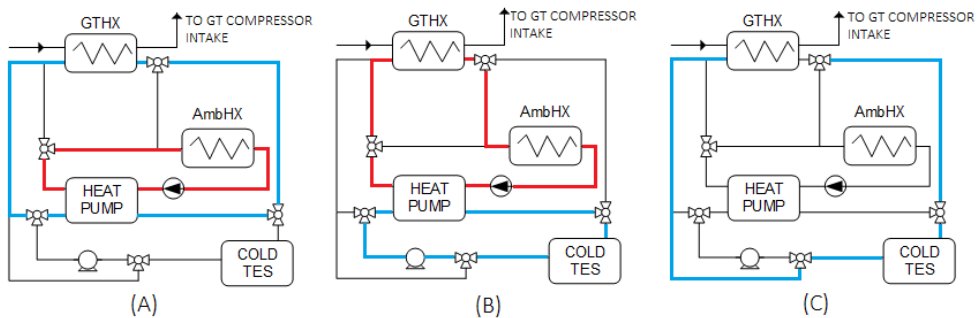

Fig. 1. Layout of the system investigated and three different operational possibilities a) Continuous cooling of GT compressor intake with the heat pump b) Continuous heating of GT compressor intake and cold storage charging through the heat pump c) Use of cold storage to cool down GT compressor intake

To operate in such a way, the controller then therefore be able to operate such operations:

- To choose the better operating layout among the trio
- To operate the correct layout in view of the requests coming from the plant
- To make the combined cycle able to sell the proper amount of energy

This has been split at two different levels, both operating in real time, but with two different control horizons [5].

- A first one looking at the 15 minutes resolution, which determines the set that is going to operate in the next period
- A second one looking at the seconds level, which directly governs the heat pump and the valves which direct the flow around the system

This means that the command flow persisting between the two levels sends information regarding

- Binary 1/0 regarding the turning on and off of the heat pump
- Power regarding the power request e.g. to the HP or to the TES
- FO set for the valves

Moreover, a flow coming to the controller externally, which is made up of

- Energy currently sold on the market by the power plant
- Power set and status of the heat pump and storage
- State of charge into the storage

4 Architecture of Command Control

The goal of the command control is allowing the run of the different algorithms with the required data that have to be get from the field. Figure 2 shows how the added command control will integrate over the existing one. For this integration, many considerations have to be taken into account to design hardware implementation:

- Interface existing plant Control Systems
- Interface new Pump Heat and the TES
- Implement the MPC Control
- Produce HMI for control of Heat Pump and TES

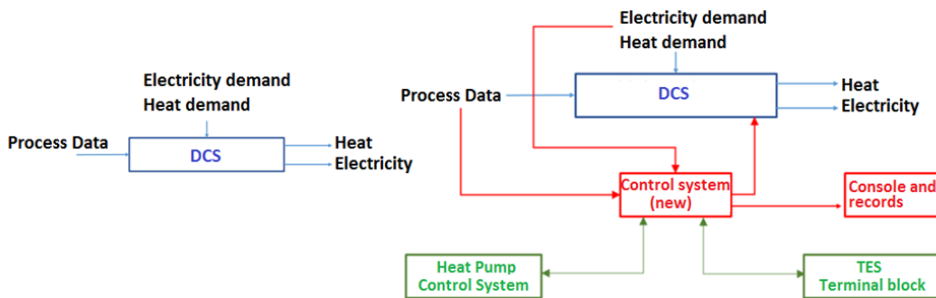

Fig.2. Integration of a new control system

All these constraints have led to choose a multi-purpose computer. It will have to integrate:

- I/O for interfaces, PLC-type
- PLC-type functions for sake of simplicity and controllability by plant automation operators
- Double Network attachment: one for interfacing other devices (Heat Pump), one for its own purpose with various devices
- Serial links if needed for other apparatus or security systems
- One CPU (or virtual machine) running scientific algorithms, with MatLab capability
- One CPU (or virtual machine) for HMI server, operational storage, Supervision firmware
- One CPU (or virtual machine) for all the test environment, storage, sequences.

As explained previously, the output of the controller governs only the HP – and TES consequently. These outputs are directly sent to the two components and in no way it will be direct control of the existing DCS. Though, an existing interaction with the DCS will be included, since the operation of the HP and the TES may influence the response of the DCS with respect to heat and electricity production of the whole power plant. As consequence, alarms for abnormal operations or conditions at HP and TES must be derived somehow else.

Figure 3 exposes the data flow of the command control. The data of HP and TES sensors are read via a Labview server. This LabView server is directly connected to an OPC UA server from which the server owning the different algorithms read the needed data. It is the interface between the algorithms and the data from the field. The different algorithms are designed with Matlab, so it is planned to use the Matlab OPC toolbox which allows to connect OPC server and the designed algorithm. For the sending of order, the data take the opposite way.

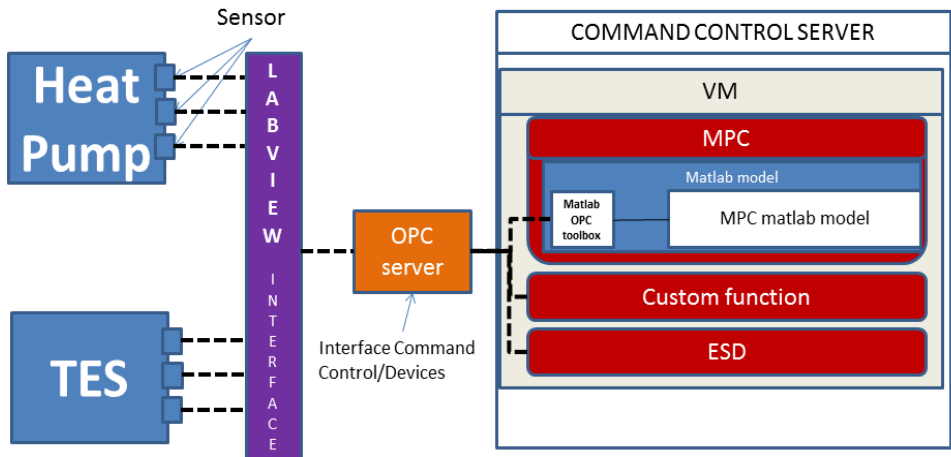

----- Bidirectional data flow

Fig.3. Data flow of the control command for the target Demo site

5 Conclusions

This paper presents the description and installation configuration for control system of a micro gas turbine test rig with connected a heat pump for inlet conditioning. The control signals are listed and divided into different types and information exchanged between controller, field data and data server. In this configuration, LabView is used as interface between the server and the control command via OPC protocol. The computational load is divided between different CPU and the level of interactions is governed by a custom function, which is yet to be defined and will constitute the next step of control implementation.

Nomenclature

AmbHX	Ambient Heat Exchanger	HP	Heat Pump
CHP	Combined Heat and Power	MEL	Minimum Environmental Load
DCS	Distributed Control System	MPC	Model Predictive Control

DHN	District Heating Network	OPC	Open Platform Communication
ESD	Emergency Shut Down	SOC	State of Charge
GTCC	Gas Turbine Combined Cycle	TES	Thermal Energy Storage
GTHX	Gas Turbine Heat Exchanger	VM	Virtual Machine

Acknowledgments

PUMP-HEAT project has received funding from the European Union’s Horizon 2020 research and innovation programme under grant agreement No 764706



References

1. R. Dickel, 2018, “The role of Natural Gas, Renewables and Energy Efficiency in Decarbonisation in Germany: The need to complement renewables by decarbonized gas to meet the Paris targets”, The Oxford Institute for Energy Studies, University of Oxford.
2. B. Nastasi, G. Lo Bisso, 2016, “Hydrogen to link heat and electricity in the transition towards future Smart Energy Systems”, Energy, vol. 110 pp. 5-22
3. www.pumpheat.eu, last access 01/07/2019
4. Giugno A., Cuneo A., Sorce A., Piantelli L., 2018, “Integration of Heat Pump and Gas Turbine Combined Cycle: layout and market opportunity” IGTC 18, Brussels
5. Rossi I., Reveillere A., Planchon F., 2018, “Intelligent predictive control of a Pump-Heat Combined Cycle: introduction and first results” IGTC 18, Brussels