

A Test Rig for the Experimental Investigation of a MGT/SOFC Hybrid Power Plant Based on a 3kW_{el} Micro Gas Turbine

Martina Hohloch^{1,}, Melanie Herbst¹, Anna Marcellan¹, Timo Lingstädt¹, Thomas Krummrein¹, and Manfred Aigner¹*

¹Institute of Combustion Technology, German Aerospace Centre (DLR), 70569 Stuttgart, Germany

Abstract. A hybrid power plant consisting of a micro gas turbine (MGT) and a solid oxide fuel cell (SOFC) is a promising technology to reach the demands for future power plants. DLR aims to set up a MGT/SOFC hybrid power plant demonstrator based on a 3kW_{el} MTT EnerTwin micro gas turbine and an SOFC module with an electrical power output of 30kW_{el} from Sunfire. For the detailed investigation of the subsystems under hybrid conditions two separate test rigs are set up, one in which the MGT is connected to an emulator of the SOFC and vice versa. The paper introduces the set-up and the functionalities of the MGT based test rig. The special features are highlighted and the possibilities of the cyber physical system for emulation of a hybrid system are explained.

1 Introduction

A hybrid power plant consisting of a micro gas turbine (MGT) and a solid oxide fuel cell (SOFC) is a promising technology to reach the demands on efficiency, emissions and flexibility for future power plants. The highest efficiencies are reached with a cycle concept where the SOFC is integrated in the MGT cycle. In this configuration, the SOFC is pressurized. The MGT benefits from the hot SOFC exhaust gases as the need for additional fuel is reduced or eliminated. Because of the scalability of such a power plant, it can be used for decentralized power generation as well as a central power station. Depending on the size, electrical efficiencies up to 70% are estimated by different numerical studies [1].

For the development of a real coupled 30kW_{el} MGT/SOFC hybrid power plant, the DLR Institute of Combustion Technology and the DLR Institute of Engineering Thermodynamics are collaborating in a long term project [2]. The MGT is based on a 3kW_{el} MTT EnerTwin micro gas turbine. An SOFC module with electrolyte supported cells from Sunfire with an electrical power output of 30kW_{el} is used. In a first step, two separate test rigs are set up for the detailed investigation of the behaviour of the subsystems under hybrid conditions and for the development of the control system. Therefore, the MGT is connected to an emulator of the SOFC and vice versa. So called cyber physical systems, where one component is replaced by an emulator controlled by a real time model are often

* Corresponding author: martina.hohloch@dlr.de

used in the field of hybrid power plant development, as they offer a lot of advantages and possibilities for the detailed investigation of one subsystem. The operational range, limitations and critical manoeuvres can be determined and analysed without harming the other subsystem. In addition, the control concept as standard routines (e.g. start-up and shutdown) and emergency manoeuvres can be developed, tested and finally integrated into the overall control system. Beside DLR [2, 3], the Thermochemical Power Group (TPG) from the University of Genoa [4] and the NETL in Morgantown (US) [5] operate cyber physical test rigs [6].

2 Hybrid power plant demonstrator

The chosen plant layout for the hybrid power plant demonstrator is shown in figure 1.

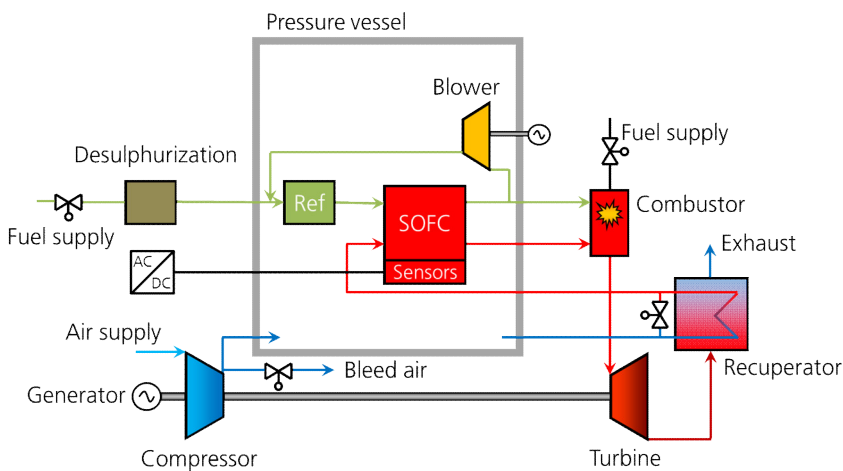

Fig. 1. Plant layout of the hybrid power plant demonstrator (modified from [2])

Here, the SOFC system is placed in a pressure vessel, the MGT is connected to it. Ambient air is compressed in the compressor and first led through the pressure vessel of the SOFC. This is done to balance the pressure inside and outside the SOFC stack. The air is then preheated in the recuperator and fed to the SOFC cathode side. Natural gas or biogas mixtures are desulphurized and pre-reformed in the reformer before they enter the anode side of the SOFC. Part of the anode exhaust gases are recirculated using a blower to provide the necessary steam content for the reforming process. The SOFC exhaust gases still contain non-reacted fuel, which is processed in the MGT combustor. The exhaust gases are expanded in the turbine and cooled in the recuperator, transferring the heat to the air side. To control the inlet air temperature of the SOFC, the MGT recuperator can be bypassed. For emergency procedures, a bleed air path is implemented at the outlet of the compressor. Hereby, air can be blown off directly out of the cycle to prevent compressor surge.

For the set-up of such a system, the requirements on each component to fit into the power plant concept, necessary optimizations and redevelopment have to be determined. On the MGT side, the recuperator and the combustion chamber are two core components. The recuperator influences significantly the pressure difference between the inside and the outside the SOFC. As the allowed pressure difference is limited, the recuperator has to be optimized with regard to minimum pressure loss on the high pressure side. This was done in collaboration with the company Hiflux. The combustion chamber has to deal with different fuel compositions with a large variety of heating values (from approximately 1.5

to 48 MJ/kg LHV) and different inlet temperatures depending on the load point. To meet these demands a new combustion system was developed [7-10] at DLR.

3 Hybrid power plant test rig based on the MGT

The main challenges in the realization of a MGT/SOFC hybrid power plant are the development of a stable and robust operational strategy, the adequate matching and the effective integration of the subsystems MGT and SOFC. This requires a deep understanding of the influence of both main subsystems on each other as well as the impact of the connecting elements. Whereas the MGT is a fast reacting system, the SOFC is subject to restrictions in pressure and temperature gradients and differences in the system. Therefore, these particular properties, such as different allowed maximum gradients, have to be considered for the development of the operational strategy for start-up, shut-down and load change. Furthermore, special emergency manoeuvres have to be developed. For the detailed investigation of the MGT and the SOFC under hybrid conditions, two separate test rigs were derived from the hybrid power plant layout and set-up. For each test rig, one of the subsystems is replaced by an emulator.

In Figure 2 the layout of the MGT system based on the MTT EnerTwin and coupled to an SOFC emulator is given. The SOFC and the coupling devices of the hybrid power plant represent an additional pressure loss in the MGT system between compressor and turbine. This has an effect on the operational range of the micro gas turbine [4]. Especially the operation of the MGT compressor is affected by higher pressure losses. Hence, it is important that the test rig emulates the estimated pressure loss of the demonstrator.

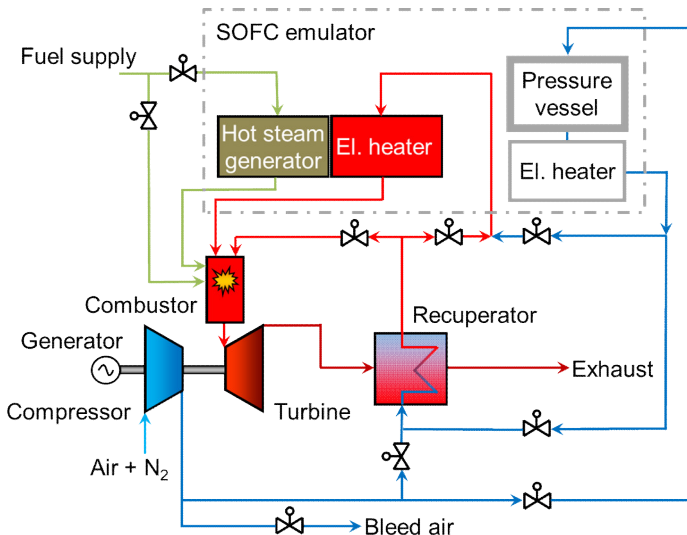

Fig. 2. Layout of the MGT hybrid power plant test rig (modified from [12])

The SOFC emulator is composed of a pressure vessel, two electric heaters and an SOFC off-gas emulator. With the combination of the pressure vessel and the first electric heater, the volume, the pressure loss and the temperature increase in the SOFC pressure vessel are simulated. The second electrical heater and the off-gas emulator provide the conditions of the exhaust gases of anode and cathode side at the exit of the SOFC stack. The off-gas emulator consists of a hydrogen/oxygen combustor and an injection device for carbon dioxide and carbon monoxide [8]. Herewith, the composition of the SOFC anode off-gas

can be emulated. In addition, nitrogen can be injected to the air supply at the compressor inlet to simulate the depleted air at the SOFC cathode outlet. With this arrangement the new combustion system, the so called MGT/SOFC off-gas combustor, can be analysed under real conditions and an operational concept can be derived.

For the detailed investigation of different operational concepts, additional bypasses are implemented in the test facility. Finally, an air conditioning system was installed at the compressor inlet to adjust different inlet temperatures.

A new control system is set up for the test rig based on the MGT control system [12]. Here, the routines can be adapted and optimized for the use in the real demonstrator. In addition, a real time model of the SOFC is implemented in the control system and can be switched on to investigate the mutual interaction of MGT and SOFC during transient manoeuvres.

The first results are shown in [12]. Here, the focus is on the control strategy for the system, showing some experimental results first driven manually and the implemented into the control system.

4 Conclusions

The presented test rig offers the possibility to analyse the influence of the hybrid configuration on the micro gas turbine as well as the reaction of the MGT under hybrid conditions. The optimized components recuperator and combustion chamber can be investigated in detail under real conditions. Especially the capability to emulate the SOFC off-gas composition of anode and cathode side at the combustor inlet should be highlighted as a unique feature of this test rig. In combination with the SOFC model coupled to the control system, the combustion system can be analysed and optimized before integration into the real coupled system. In addition, the procedures and manoeuvres of the control concept can be validated and adapted for the real demonstrator without a risk of damages for the SOFC system. This also minimizes the risks for the real coupled demonstrator.

The next steps will be the commissioning of the system with the optimized components and the experimental characterization in steady state as well as transient conditions, the investigation of dynamic behaviour and validation of control concept.

5 Acknowledgements



This project has received funding from the European Union's Horizon 2020 research and innovation programme under grant agreement No 641073 (www.bio-hypp.eu).

Furthermore, the support from the German Federal Ministry of Economic Affairs and Energy for the project “DemoHydra” is gratefully acknowledged. (Support code: 03ET6032).

Nomenclature

DLR	German Aerospace Center	NETL	National Energy
EL	electrical		Technology Laboratory
HyPP	hybrid power plant	N ₂	Nitrogen
LHV	lower heating value	REF	catalytic steam reformer
MGT	micro gas turbine	SOFC	solid oxide fuel cell
MTT	Micro Turbine Technology	TPG	Thermochemical Power
	B.V		Group

References

1. S. E. Veyo, S. D. Vora, W. L., Lundberg; K. P. Litzinger, Tubular SOFC Hybrid Power System Status, *Proceedings of the ASME Turbo Expo*, (2003), GT2003-38943.
2. M. Henke, M. Steilen, C. Schnegelberger, M. Riedel, M. Hohloch, S. Bücheler, M. Herbst, A. Huber J. Kallo, K.A. Friedrich, Construction of a 30kW SOFC Gas Turbine Hybrid Power Plant, *ECS Transactions*, 68.1, page 85-88, (2015).
3. M. Hohloch, A. Huber, M. Aigner, Analysis of Operational Strategies of a SOFC/MGT Hybrid Power Plant, *Proceedings of the ASME Turbo Expo*, (2017), GT2017-65013.
4. M. Pascenti, M.L. Ferrari, L. Magistri, A.F. Massardo, Micro Gas Turbine based Test Rig for Hybrid System Emulation, *Proceedings of the ASME Turbo Expo*, (2007), GT2007-27075
5. D. Tucker, E. Liese, J. VanOsdol, L. Lawson, R.S. Gemmen, Fuel Cell Gas Turbine Hybrid Simulation Facility Design, (2002), ASME Paper No. IMECE2002-33207
6. I. Rossi, A. Traverso, M. Hohloch, A. Huber, D. Tucker, Physics-Based Dynamic Models of Three SOFC/GT Emulator Test Rigs, *Journal of Engineering for Gas Turbines and Power*, 140(5), 051702, (2018).
7. S. Bücheler, A. Huber, M. Aigner, Investigation of fuel flexibility of a jet stabilised combustion system for micro gas turbines, *8th European Combustion Meeting*, (2017).
8. S. Bücheler, A. Huber, M. Aigner, Development of a Jet-Stabilized Combustion System for the use of Low-Caloric SOFC Off-Gas, *Proceedings of the ASME Turbo Expo*, (2017), GT2017-64447.
9. T. Lingstädt, F. Grimm, T. Krummrein, S. Bücheler, M. Aigner, Experimental investigations of an SOFC off-gas combustor for hybrid power plant usage with low heating values realized by natural gas addition, *Proceedings of GPPS Forum*, (2018), GPPS-2018-0052.
10. T. Lingstädt, F. Grimm, T. Krummrein, P. Kutne, M. Aigner, Atmospheric Experimental Investigations of a Jet-Stabilized SOFC Off-Gas Combustor for a Hybrid Power Plant operated with Biogas, *AIAA SciTech Forum*, (2019).
11. J. Zanger, A. Widenhorn, M. Aigner. „Experimental Investigations of Pressure Losses on the Performance of a Micro Gas Turbine System“, *Journal of Engineering for Gas Turbines and Power* 133.8 (2011), p. 082302.
12. A. Marcellan, M. Hohloch, M. Herbst, T. Lingstädt, T. Krummrein, M. Henke, M. Aigner, Control Strategy for a SOFC Micro Gas Turbine Hybrid Power Plant Emulator Test Rig, *AIAA*, 1676 (2019).