

Investigation of interaction of particles of pollution and gas bulb in flotation of wastewater waters

Elena Nazimko^{1*}, *Sergei Malko*¹, *Anna Semenova*¹, and *Vladimir Dorovskoy*¹

¹Kerch State Maritime Technological University, 98309, 82, Ordzhonikidze Street, Kerch, Ukraine

Abstract. The interaction of phases is at the basis of many technologies in different industries. Flotation method is used in wastewater treatment plants to capture and remove contaminants from wastewater. In this case, the interaction of air bubbles with particles of pollution with a hydrophobic surface. These interactions are very difficult to investigate because they are dynamic, subject to a large number of physical and chemical factors, and occur on a small scale. The processes mentioned above have traditionally been studied by laboratory experiments. These tests are tedious and time-consuming and show unsatisfactory accuracy. Analytical studies give idealized results. One of the most powerful alternatives for solving this problem is numerical modeling, which combines dynamics, accuracy and consideration of sophisticated details. This model is based on the discrete elements method. In this paper, a computer model for modeling the kinetics of the interaction of phases in wastewater treatment is considered.

1 Introduction

Every year, water consumption in developed countries is constantly growing. Main cause of this is a growing number of cities and other settlements, with the development of industry and the chemicalization of agriculture. Increasing the volume of water consumption entails an increase in the amount of sewage.

Sources of pollution and contamination of water bodies are large volumes of insufficiently treated sewage from industrial, agricultural and communal enterprises, transport and other industries. According to the research, the river flow annually brings to the World Ocean about 2.3 million tons of lead, 1.6 million tons of manganese, 6.5 million tons of phosphorus, 230 million tons of iron, sulfuric acid and its salts, pesticides, surfactants, phenols, radioactive waste, organic matter and other contaminants [1].

Sewage is a complex heterogeneous system of pollutants that are in an undissolved, dissolved and colloidal state. Pollution of water in many rivers leads to disruption of natural processes of self-purification of water bodies. This greatly complicates the work on obtaining quality drinking water.

* Corresponding author: esiap@mail.ru

In modern sewage treatment plants, various methods are used to purify sewage with the aim of reusing them and reducing the content of harmful contaminants. The purification technology depends on the composition of impurities. At the same time, it is practically impossible to bring the discharged water to the required standards in one processing stage [2]. Usually technological schemes are used, consisting of a number of operations. To sewage as a complex system is often used physicochemical methods of purification. One such method is flotation.

2 Flotation problems

Flotation methods are based on the ability of particles to adhere to gas bubbles and is used to extract dispersed and colloidal inclusions from the liquid phase. Flotation is used to extract heavy metal ions from effluents, in the food and microbiological industries, to recover the dispersed phase of the emulsion, as well as petroleum products, release of particulate matter and other purposes [2-7]. At the same time, flotation complexes are formed, aggregates "particle - gas bubbles" that float up in the flotator, taking out various kinds of contaminants in the foam layer.

Depending on the method of formation of gas bubbles, there are pressure, pneumatic, mechanical, electroflotation, foam, chemical, vibrational, biological and other types of flotation. But whatever the method of gas dispersion with the formation of bubbles, the elementary act of flotation is based - the collision of a particle with a bubble and the formation (or its absence) of a flotation complex [8].

The formation of flotation complexes depends on a number of parameters: the intensity of the collision of particles of contaminants with gas bubbles, the ratio of their velocities and sizes, the properties of the surface of the colliding substances, chemical interaction, etc. [9]. In this connection, the study of the processes occurring during to the contact and interaction of bubbles with hydrophobic and hydrophilic particles and their influence on the formation and stability of the flotation complex is of particular relevance and significance.

The aim of the work is to develop a simulation technique and study the influence of the parameters of interacting elements and collision conditions on the formation of a particle-bubble aggregate.

Researchers usually use full-scale experiments, as well as analytical methods for describing these processes, which raise more questions than give answers. One of the modern ways of studying various complex interactions is numerical simulation using the Discrete Element Method (DEM) [8]. Based on the algorithm published in [9], a software package for modeling was created. The main theoretical principles of the method are presented in [10,11]. The same method was used to study a number of other processes. The basic scheme of interaction of two elements is shown in Fig. 1.

In this model, the size of the spherical elements is given by the radius $R1$ and $R2$. Elements move under the action of forces $F1$ and $F2$. In collisions of elements, their rotation arises in accordance with Newton's law from the action of the moments $M1$ and $M2$. The movement of elements and their interaction is considered at discrete time periods in a rectangular X-Y coordinate system (Figure 1). In a computer implementation, these periods are modeled as account cycles. Within each cycle, the coordinates of the centers of gravity of the elements $X1$, $Y1$ and $X2$, $Y2$, the velocities $V1$ and $V2$, and the forces acting are constant. When we move to the next time interval (cycle), their values are recalculated.

Then the elements are moved to new positions in accordance with the forces acting on them.

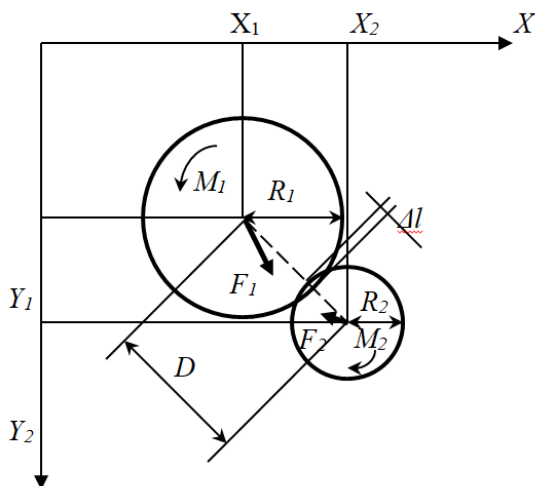

Fig.1. Interaction of two elements – the original DEM scheme

A permanent vertical acceleration g , corresponding to the acceleration of the free fall of the body, is applied to all elements of the model. As a result of its impact, the elements cyclically receive an increment or decrease in speed. Decreasing in speed (inhibition of the element) appears when the direction of action of the resultant forces is opposite to the direction of the velocity vector of the movement of the elements. The equal force arises from the action of gravity, the Archimedean (location) force, the resistance force of the environment, and also from the influence of adjacent elements - "neighbors".

Each program element is assigned a number. Therefore, it is possible to follow the change in the coordinates of its center of gravity, which determine the position of the element in space. During the simulation, all elements are sequentially searched in order of increasing their number.

The reliability of simulation results is ensured by observing dynamic, kinetic and geometric similarity [8,10]. Geometric similarity is ensured by the equality of the ratio of the sizes of interacting elements in kind and in the model. Dynamic similarity is performed by observing a certain scale, by which is meant the similarity of forces, velocities and accelerations in nature and in the model. The kinematic similarity presupposes the similarity of the trajectories of the motion of points in nature and in the model, while the velocities and accelerations differ by an equal number of times. In kinematic similarity, there is a time scale. In addition, the initial state of the system under study is consistent in nature and in the model, as well as the sequence of ongoing processes.

3 Modelling of structural components and processes

The initial file specifies the initial speeds of the element along the axes, the initial speed of rotation, and the acceleration. Also introduced a number of coefficients that reflect the properties of the separation medium and elements: rolling friction and slip coefficients, viscosity resistance, torsional resistance, tangential and normal rigidity, and others. In this

way, the parameters of the motion and the properties of the elements are determined, which affect the indices of the removal of contaminants from the sewage during their processing.

The algorithm for performing operations can be presented in the following simplified form. From the general laws of physics, it is known that the force acting on an element on a certain counting cycle n is related to the mass of the element and the acceleration by the relation:

$$F_n = a_n m . \quad (1)$$

Where F_n is the force acting on the element, m is the mass of the element, a_n is the acceleration of the element, and n is the number of the counts.

The acceleration and velocity of the element on the n -th count cycle are defined as:

$$a_n = \frac{F_n}{m} , \quad (2)$$

$$V_n = \int_0^t a_n dt . \quad (3)$$

Here dt is the increment of time in one counting cycle, sec.

The user specifies a time increment Δt of 10^{-4} - 10^{-6} sec, which for very small values in the limit tends to dt .

After determining the speed, the changes in the coordinates of the center of gravity of the element are calculated as:

$$\Delta X_n, \Delta Y_n = \int_0^t V_n dt . \quad (4)$$

Then the program proceeds to the next cycle of the account, the new coordinates of the center of gravity of the element are determined as:

$$X_{n+1} = X_n + \Delta X_n, Y_{n+1} = Y_n + \Delta Y_n . \quad (5)$$

Based on the calculations, the elements that moved to a new position and new values of the resultant forces arising from the interaction of the elements are determined as:

$$F_{n+1} = k \Delta l_n , \quad (6)$$

where k is the damping coefficient, taking into account the resistance of the medium, as well as the energy losses in the interaction of the elements, the stiffness of the material of the elements and other parameters, and Δl_n is the overlap of the surfaces of the elements that arises during collisions and interactions.

On the new counting cycle, the parameters for the elements are recalculated according to the relations (1-6) given above, starting from the value of the force F_{n+1} . Then the elements move to the next position, corresponding to the increment of the velocity and time components. After moving the element to a new position in one cycle, the distance D between the centers of gravity of adjacent elements changes and the overlap ΔL is determined again.

The result of the simulation is animated images on the monitor and digital files that contain the coordinates of the centers of gravity of the elements, the angles of rotation of their radius at each time of the counting. Work with the software package consists in preparing the source data file, performing the calculation, analyzing the results.

When solving the problem in application to flotation, the interaction of the air bubble rising with a suspended particle in the liquid at different collision angles φ_0 was considered (Fig. 2).

The current position of the particle (shown by dotted line) as it moves along the surface of the bubble is determined by the angle φ_i (see Fig. 2).

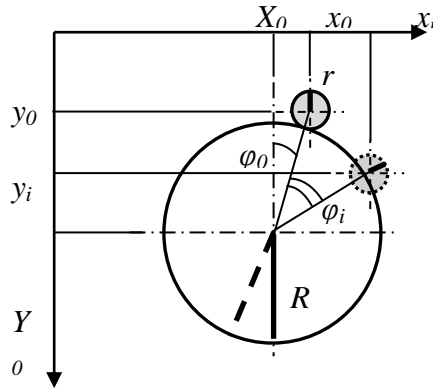

Fig. 2. Adaptation of DEM method for flotation - interaction of a particle of pollution and a gas bubble

To verify the adequacy of the model, a comparison was made between the results of the well-known experiment [12] and the simulation results (Fig. 3). In the experiment, hydrophobic particles were used, falling on a pop-up bubble with a different displacement relative to its center of gravity (Fig. 3a). In modeling, an analogous displacement was set by changing the angle of collision of the elements φ_0 (Fig. 3, b). Also, a comparison was made between the experiment and the simulation results of air bubble motion along an inclined plate covered with hydrophobic particles [8]. Comparison of the experimental data and the model indicate their qualitative agreement.

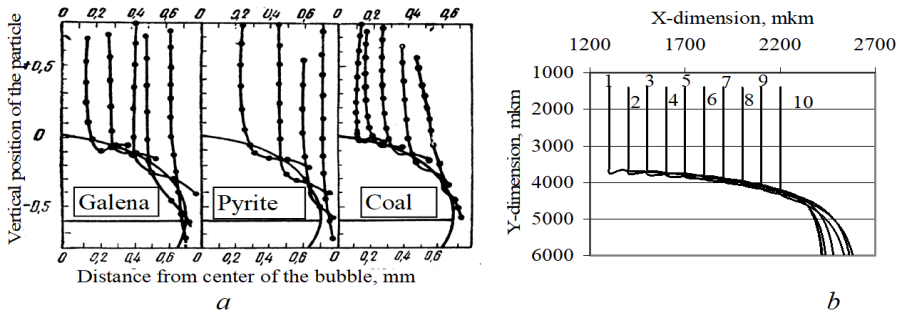

Fig.3. Experimental (a) and computer modelling data (b)

When studying flotation process, the simulation for the central collision was performed, when the centers of gravity of the hydrophobic particle of contamination and the gas bubble were on the same vertical line ($\varphi_0 = 0^\circ$), and at a small collision angle $\varphi_0 = 5^\circ$. At the central collision, the particle is fixed at the highest point of the bubble and the resulting complex emerges.

4 Parametric analysis of the model

When processing digital files for $\varphi_0 = 5^\circ$, the trajectories, velocities and accelerations of the elements (in conventional units) are obtained. The fragment of the digital file and the results of its processing are shown in Table 1.

Table 1 - Fragment of a digital file received as a result of the software package processing

Software package processing results				Processing results - calculation of motion parameters					
Cycle	Time, s	X, pks	Y, pks	dX	dY	ddX	ddY	Velocity $V = (dX^2 + dY^2)^{1/2}$	Acceleration <i>a</i>
...
4400	0.0044	4303.009	5485.695	0.857	0.076	-7.051	-0.418	7.10	0.42
4600	0.0046	4303.935	5478.230	0.926	0.069	-7.465	-0.414	7.52	0.42
4800	0.0048	4304.945	5470.357	1.01	0.084	-7.873	-0.408	7.94	0.42
5000	0.0050	4306.048	5462.085	1.103	0.093	-8.272	-0.399	8.35	0.41
5200	0.0052	4307.254	5453.423	1.206	0.103	-8.662	-0.39	8.75	0.40
5400	0.0054	4308.569	5444.382	1.315	0.109	-9.041	-0.379	9.14	0.39
5600	0.0056	4309.999	5434.967	1.43	0.115	-9.415	-0.374	9.52	0.39
5800	0.0058	4311.558	5425.196	1.559	0.129	-9.771	-0.356	9.89	0.38
6000	0.0060	4313.258	5415.084	1.7	0.141	-10.112	-0.341	10.25	0.37
...

Based on the processing of digital data, it is determined that when a hydrophobic particle collides with a gas bubble, a sharp shock occurs. At the same time, the velocity and acceleration of the elements decrease by several orders of magnitude. After this, if the flotation complex is formed, it continues to float up.

It is also established that when a collision occurs, the surface of a floating bubble bends to some extent (Fig. 4). The size of the deflection was determined by calculating the difference S: the distance between the centers of gravity of the elements minus the sum of their radius (see the scheme in Fig. 4a). This difference was calculated from the ratio:

$$S = l - (R + r), \tag{7}$$

where S - difference; L - the current distance between the centers of gravity of the elements; R and r are the bubble and particle radius, respectively.

The data in Fig. 4 show that the deflection and vibrations of the surface of the bubble occur without destroying it. Similar phenomena were observed with the accelerated filming of the formation of the flotation complex.

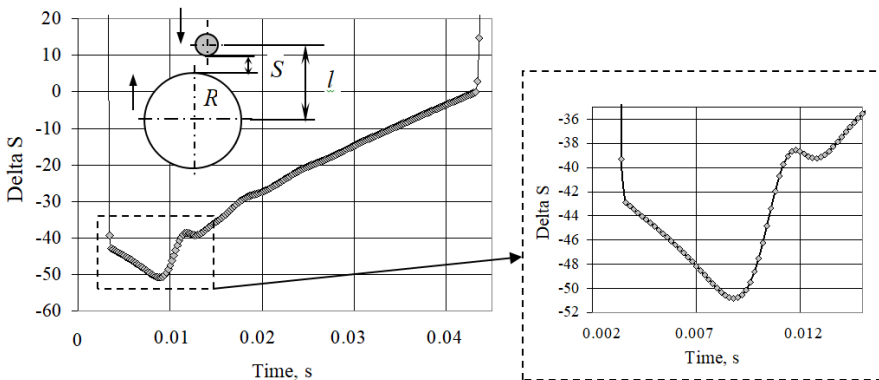

Fig. 4. Deflection of the bubble surface upon contact with a hydrophobic particle: a - general view, b - enlarged section

By the location of the markers on the graph (Fig. 4b), it is seen that after falling to the surface of the bubble, the particle flexes its elastic hydrated shell and the parameter S varies slowly in the section BC. It should be noted that all markers correspond to equal time intervals. After reaching a certain amount of deflection at point C, the bubble begins to "correct" its surface and pushes out the particle. On the section of CD, the change in the

values of the parameter S is much higher for the same period of time. This is evidenced by the distances between the markers along the Y axis. On the section DE this process slows down. The particle again bends the surface of the bubble, but not so deep - the section of EF . On the FG site and further the bubble restores its surface, the formed "particle-bubble" complex emerges.

When the complex emerges, the particle of contamination moves along the surface of the bubble until it finally settles on its lower hemisphere [13]. This can be seen on the monitor screen and the results of processing digital files. At the same time, the elements rotate relative to each other, as evidenced by the change in the position of the radii of the elements. This can also be seen on the monitor. The trajectory of the gas bubble is shown in Fig. 5, in Fig. 6 - the trajectory of the particle in the coordinates of the bubble.

At the time point corresponding to point A , the hydrophobic particle collides with a bubble rising upward with an offset from its vertical axis by an angle $\varphi_0 = 5^\circ$. The bubble moves to the left. After initial contact, the particle slides over the surface of the bubble. At the moment of time corresponding to point B , the particle is in the extreme right position on its spherical surface (see Fig. 5b). The location of the markers on the particle trajectory relative to the bubble indicates an increase in the slip velocity of the particle in the AB region (see Fig. 6a).

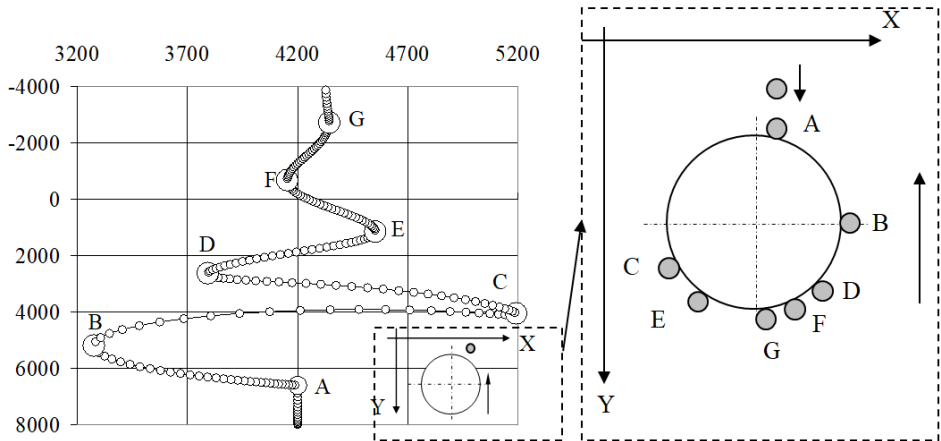

Fig.5. The trajectory of the bubble and the position of the particle on its surface during the formation of the flotation complex: a – the trajectory of the bubble, b – enlarged fragments of the particle position change on the bubble.

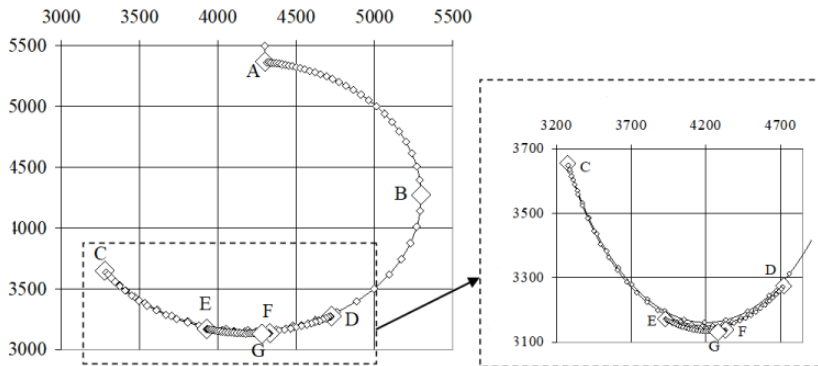

Fig. 6. Particle motion in the coordinates of the bubble: *a* - displacement of the particle along the surface of the bubble, *b* - an enlarged fragment of the trajectory of motion on the lower hemisphere of the bubble.

The kinetic energy collected by the particle in this region and after point B allows it to rise on the left side of the bubble's hemisphere up to point C. At the end of the ascent, the velocity of movement relative to the bubble is reduced to a minimum. The bubble, while continuing to float, moves with a high velocity to the right to point C, as evidenced by the distances between the markers along the X axis in Fig. 5a.

Braking at point C, the particle again slides down and rises to point D on the surface of the bubble (see Figure 5b and Figure 6b), which is located on the hemisphere of the bubble below point C. The bubble as a result of these displacements deviates left to point D with variable speed (see Figure 5a) - slowing down, accelerating and slowing down again. Changes in the velocity of motion of the bubble are associated with fluctuations in the velocity of sliding of the particle along its surface.

From point D, the particle slides along the bottom hemisphere of the bubble to point E, causing the bubble path to deviate to the right (see Figures 5 and 6). Further, the motion of both elements gradually slows down to reach point F and at point G the particle is fixed on the bottom hemisphere of the bubble. The formed flotation complex floats up in the flotation cell.

5 Conclusion

Thus, it has been established that the formation of a flotation complex results in the deflection and vibrations of the elastic surface of the bubble at the moment of the collision. Then there is a sliding of the particle along the surface of the bubble, a change in the speed and other parameters of the displacement of the elements, their rotation relative to each other. Before the final fixation of the particle on the bubble, its motion is formed, resembling damped oscillations.

A number of researchers have shown in rather complicated experiments using microphotography that hydrophobic particles slide along the surface of air bubbles and turn when a flotation complex is formed. However, it was not possible to consider these processes in detail at that time. And only computer modeling and numerical methods of research contribute to a deeper and more comprehensive study of such rapidly occurring processes.

Further studies may be aimed at investigating the effect of the magnitude of the displacement of the point of contact between a particle and a bubble on the formation of a flotation complex, the relationship between the rates and sizes of interacting elements and other parameters. This will contribute to the improvement of flotation technology and apparatus used for treating wastewater.

References

1. Z.M. Shulenina, V.V. Bagrov, A.V. Desyatov, *Water is man-made. Problems, technologies, resource value* (Moscow: 2015)
2. E.S. Antonova, *Ecol. Indust. Prod.*, **1 (93)**, 36-40 (2016)
3. S.N. Kapitonova, *Wat. Purify. Wat. Treat. Wat. Sup.* 36-40 (2016)
4. B.S. Xenophonov, *Ecol. Indust. Prod.*, **№2 (82)**, 27-31 (2013)
5. B.S. Ksenofontov, *Wat. Pract.Tech.*, **9**, 392-397 (2014)
6. E.A. Titov, *Wat. Purify. Wat. Treat. Wat. Sup.*, **5**, 14-19 (2016)
7. Ksenofontov, *Wat. Purify. Wat. Treat. Wat. Sup.*, **9**, 28-32 (2010)

8. L.I. Nazimko, Proce. XV Int. Congr. Of CP., **2**, 785-798
9. R.A. Cundall, Geotech., **29(1)**, 47-65
10. E.E. Garkovenko, *Features of flotation and dehydration of finely divided carbonaceous materials* (2002)
11. E.I. Nazimko, Ea. Euro. J. Adv. Tech., **5 (79)**, 12-18, 2016
12. P.F. Whelan, Bull. Inst. Min. A. Met., **591** (2016)
13. V. Budnik, S. Chernyi, Proc. Eng., **150**, 2150-2156 (2016) DOI:
10.1016/j.proeng.2016.07.256