

Effect of Drop Orientation on Structural Integrity of a Shipping Container for Nuclear Fresh Fuel

Supil Ryu^{1,*}, Joohong Chun¹, Namgyu Park¹, and Seungjae Lee²

¹KEPCO NF, Nuclear Fuel Development Section, 34057 Daejeon, Korea

²KEPCO NF, Nuclear Fuel Technology Department, 34057 Daejeon, Korea

Abstract. A shipping container of fresh fuel in nuclear industry is used to prevent a leakage of un-irradiated radioactive materials and to maintain an integrity of nuclear fuels during transportation. In this study, the drop behavior was predicted and the effect of drop orientation on structural integrity of a shipping container in case of 9 m free drop was studied. LS-DYNA which is a computer code designed to perform nonlinear dynamic analysis using explicit time integration was used in numerical analyses. The material properties were applied to the analysis model to predict the nonlinear transient behavior and three kinds of drop orientations were considered. The analysis results such as accelerations, reaction forces and internal assembly deformations were compared for each case in terms of the containment and confinement systems. Test results showed that a significant impact energy was absorbed by the polyurethane foam and shock absorbers. The drop orientations that have the greatest impact on the containment and confinement systems were Case 1 and Case 3, respectively. Through this study, these study results can be applicable to the container design modification and the shipping container development.

1 Introduction

A shipping container used for the shipment of fissile material such as fresh fuel assembly in the nuclear industry is utilized to prevent leakage of un-irradiated radioactive materials and to maintain integrity of nuclear fuels during transportation [1]. It must maintain subcritical under hypothetical accident conditions and the structural behavior is important to maintain the integrity of the shipping container based on design requirements [2-4]. Because the damage of container structure can cause a nuclear criticality or dispersion of the un-irradiated radioactive materials, it should be restricted [3, 4]. Especially, the 9 m free drop of the container stated in regulatory requirements is required to drop in a position for which maximum damage is expected [2].

The factors affecting the structural integrity of shipping container can be divided into two aspects which are containment and confinement systems. The containment system means the assembly of components of the container intended to retain the radioactive material during transport [2]. In other word, the fuel rod cladding containing the uranium pellets stacked inside in fuel assembly is regarded as the containment system. The confinement system is the assembly of packaging components as intended to preserve criticality safety for the shipping container [3]. The lid assembly and T-frame form the envelope to prevent outward expansion of fuel rods and these are regarded as the confinement system in shipping container.

In this study, the finite element model of the shipping container was developed and the finite element analyses were performed to evaluate the structural characteristics. Several drop orientations were considered to study the effect on the structural integrity of the container. A variety of results such as accelerations, target reaction forces and envelope deformations were compared in terms of containment and confinement systems. LS-DYNA [5] which is an advanced general-purpose multi-physics simulation software package was used for the transient structural analyses.

2 Configuration

Figure 1 shows the overall shape of the nuclear fuel shipping container. The container is composed of a pair of mating semi-cylindrical shells with both ends plugged. The upper and lower shells are double layered with the inner and outer shells charging the fire retardant polyurethane foam which is used for shock absorption and thermal insulation. Four shell pads are installed on the upper shell to each corner to allow vertical stacking of shipping containers during storage. It also serves as the connection for the lifting device during handling. The upper shell is removable to load and unload the fuel assemblies. The internal structures composed of lid assemblies, cradle assembly and T-frame accommodate and secure the two fresh fuel assemblies. Shock absorbers connected to lower shell support the internal structures and reduce vibration forces from outside.

* Corresponding author: spriu@knfc.co.kr

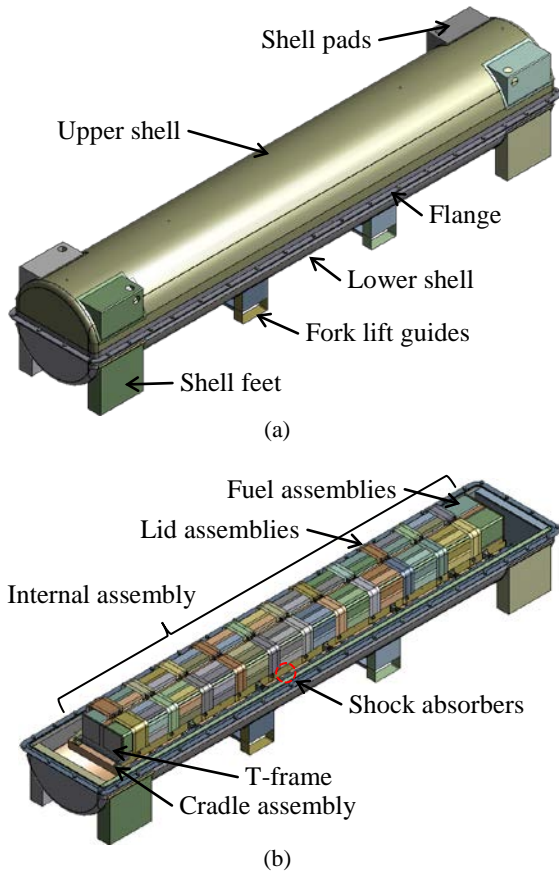

Fig. 1. Configuration of nuclear fuel shipping container (a) all components (b) without upper shell

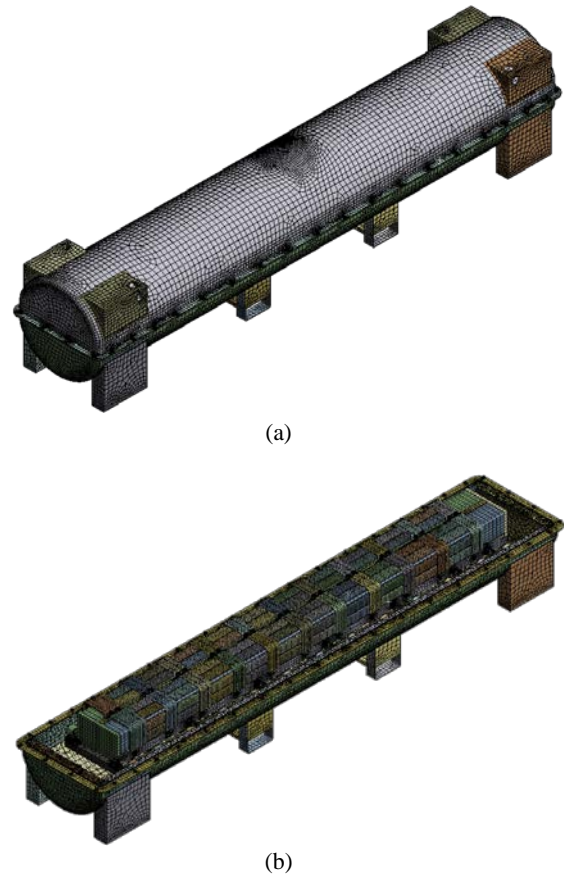

Fig. 2. Finite element model for drop analyses (a) all components (b) without upper shell

3 Finite element model

Figure 2 shows the finite element model of the shipping container for explicit transient analysis. Only structural components were maintained in the finite element geometry and some design features were simplified. The model mainly consists of shell elements to represent the plates. The polyurethane foams were modelled using solid elements. The fuel assemblies were simplified and modelled as a rectangular brick using solid elements. Bolts in the model and shock absorbers installed between the inner shell and the cradle assembly were modelled using beam elements. The number of nodes and elements are 161,890 and 204,462, respectively.

4 Structural analysis

The regulatory documents say that the shipping container should be free drop through a distance of 9 m onto a flat, essentially unyielding, horizontal surface, striking the surface in a position for which maximum damage is expected [2]. To compare which drop orientation causes the maximum damage to the integrity of the container, three types of drop orientations were considered as shown in Table 1. Conservative temperature conditions under the requirements were also considered due to the temperature effect of the polyurethane foams.

Table 1. Analysis conditions for free drop

Case	Drop description	Temp. condition
1	Slap-down drop on upper shell	Cold (-40°C)
2	Slap-down drop on flange	Cold (-40°C)
3	Slap-down drop on corner	Cold (-40°C)

4.1 Material properties

Most components of the container are made of stainless steel except for polyurethane foams and shock absorbers. Temperature-dependent material properties used for the analysis of the container obtained from the ASME B&PV Code and ASTM Standards. The material properties of polyurethane foams and shock absorbers derived from the material sample tests. The material properties of A240 type 304 which is the representative material used in the container are shown in the Table 2 [6].

Table 2. Material properties for A240 type 304

Material property	Value
Young's modulus	195,000 MPa
Poisson's ratio	0.31
Yield strength	205 MPa
Tensile strength	515 MPa

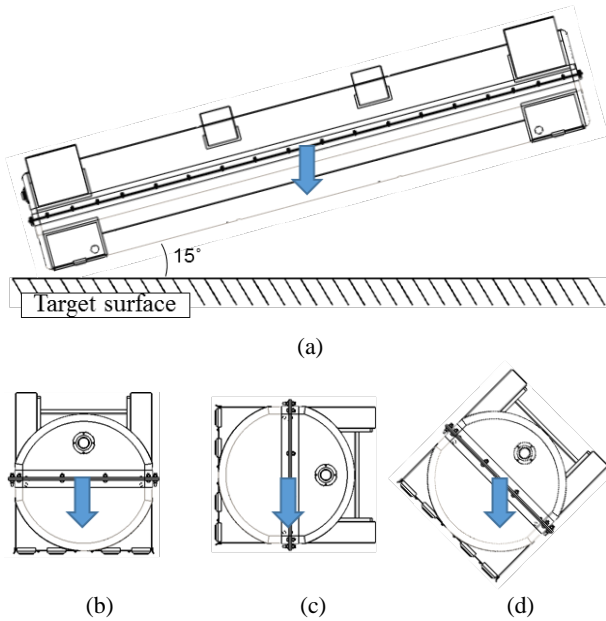

Fig. 3. Drop orientations (a) drop onto the target surface for side view of case 1 (b) front view of case 1 (c) front view of case 2 (d) front view of case 3

4.2 Boundary conditions

Regulatory requirements require that the container should be drop at the most damaging angle. Previous tests suggest that the slap-down impact may be more severe than other orientations [7]. The shipping container drops at an angle of 15 degrees to the target surface in three cases as shown in Figure 3. The finite element model of the container is placed directly in contact with the target surface. An initial velocity is set such that the container has the kinetic energy equivalent to the potential energy at the drop height. Equation (1) to calculate the initial velocity is as follows:

$$V_0 = \sqrt{2gh} \quad (1)$$

where V_0 , g and h denote the initial velocity at drop height, gravitational acceleration and drop height, respectively. The initial velocity of 9 m free drop is decided to 13.3 m/s from above equation.

4.3 Analysis results

4.3.1 Energy – time history

Figure 4 shows the energies as a function of time history during the drop transient of case 1 representatively. The kinetic energy gradually decreases by 25% during the first impact between 0 and 0.03 seconds and rapidly falls to almost zero during the second impact around 0.075 seconds. The internal energy changes inversely to the kinetic energy and the total energy keeps nearly constant. Hourglass modes are nonphysical modes of deformation that occur in under-integrated elements and produce no stress. In this reason, hourglass energy should be limited to a small fraction of the total energy. Figure 4 says that the hourglass energy is less than 1% of the total energy

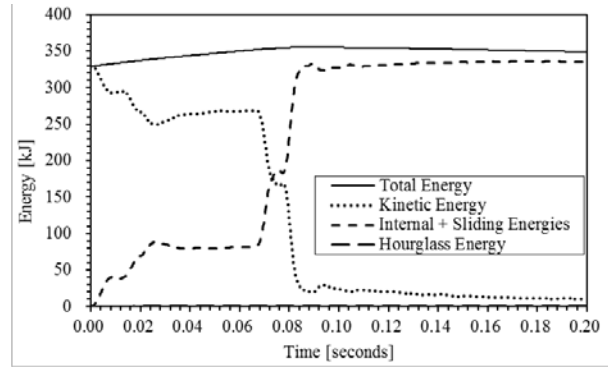

Fig. 4. Energy-time history for drop case 1

in case 1. The energy-time histories of other analysis cases show also similar aspects.

4.3.2 Accelerations

The acceleration-time histories were compared for each case to study the effect of drop orientation on the acceleration during impact. The accelerations at specific locations were obtained.

Figure 5 shows the total acceleration history for case 1 at the three locations considered. Location 1 and 3 indicate near the top end and the bottom end of the internal assembly each other. Location 2 is in the middle of the internal assembly. The high acceleration is shown at location 3 around 0.02 seconds which experiences the first impact. And then, the peak total acceleration occurs at location 1 around 0.08 seconds. This behavior is a result of the transformation of linear kinetic energy to rotational kinetic energy during drop impact.

Figure 6 presents the total accelerations at location 1 which is the second impact area for each case. All cases show the similar histories and generate the peak accelerations between 0.08 and 0.09 seconds when the second impact area hits the target surface. Case 1 shows the highest total acceleration among them.

4.3.3 Reaction forces

The reaction force is related to the structural integrity of containment system in the shipping container. A serious reaction force causes the gross failure of fuel rod cladding which is the containment system. And then, it might occur the dispersion of fissile material.

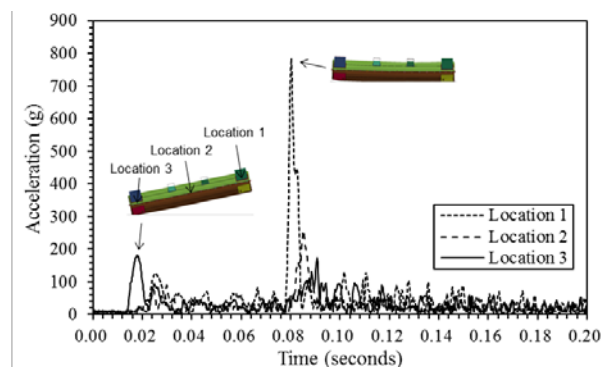

Fig. 5. Acceleration-time history for drop case 1

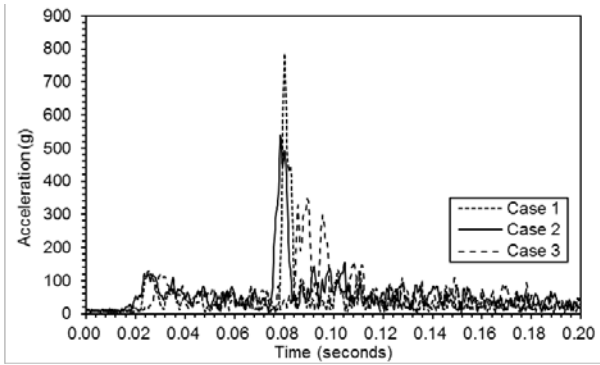

Fig 6. Acceleration-time history at location 1 for each case

There are target reaction forces for each case in Figure 7 and it shows four peak reaction forces. The first and second peaks occur during the first impact and then rest peaks are generated during the second impact. The first peak reaction force occurs when the outer shell strikes the plane while the internal structure continues its free fall around 0.01 seconds. And then, the internal structure hits the inner shell during the first impact about 0.03 seconds. The time delay between two peaks during the first impact is due to the gap between the outer shell and the internal structure. After the first impact, the outer shell of the opposite end impacts the plane around 0.07 seconds and the internal structure hits the inner shell immediately about 0.09 seconds during the second impact. In this process, the highest impact force generates at the second impact of the internal assembly. Changed rotational kinematic energy from the linear kinematic energy causes high impact force. A significant amount of impact energy is absorbed by polyurethane foams right after impact of shipping container.

Case 1 has the highest reaction force. In this case, the shock absorbers are subjected to shear load dominantly during the slap-down on the upper shell. It is not enough to absorb the kinematic energy of internal assembly and it results in significantly higher reaction force. In the case 2, half of the shock absorbers are subjected to compression load while the other half are subjected to tensile load during the slap-down on the flange. The shock absorbers in compression absorb the kinematic energy of internal assembly considerably. It prevents the internal assembly transmits high impact load to the inner shells. Therefore, the peak reaction forces in case 2 appear lower than those of case 1 as a result. Case 3

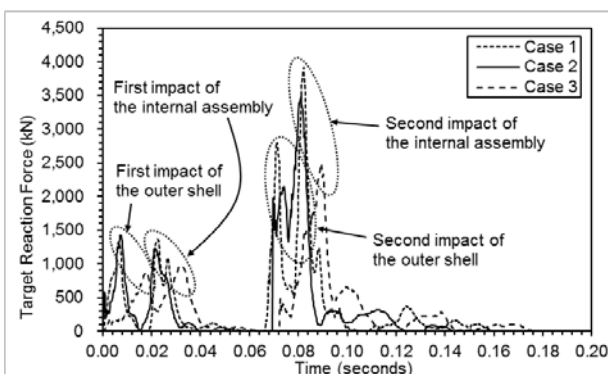

Fig. 7. Target reaction force-time history for each case

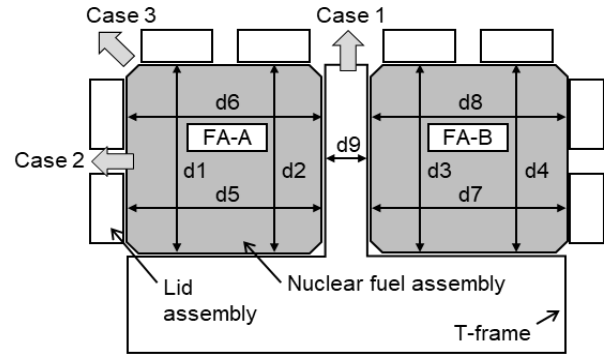

Fig. 8. The simplified cross-section geometry of internal assembly

presents the lower peak reaction forces than other cases because the shell pads which are installed on the upper shell and shock absorbers absorb the significant amount of impact energy.

For all cases, case 1 with the highest total acceleration in Figure 6 generates the highest impact force as shown in Figure 7. It means that the high acceleration transmits a large impact to the shipping container structures. It can lead to weakness of structural integrity.

4.3.4 Internal assembly deformations

The internal assembly deformation is related to structural integrity of confinement system in the shipping container. A severe dimensional change in the confinement system causes the nuclear criticality.

To compare the effect of the drop orientation on the confinement deformation, the deformations of cross-section area at location 1 which experiences the most severe acceleration were measured for each case. Figure 8 shows the simplified cross-section geometry of internal assembly and the region where the deformations were measured. Left-side is set to FA-A and right-side is set to FA-B as shown in Figure 8.

Figure 9 and Table 3 show the confinement deformations according to the distances in Figure 8. A positive value means that the distance increased after the drop. In general, the high deformations occurred in vertical measurement regions (i.e., d1 ~ d4) in case 1 and both FA-A and FA-B have similar deformations. On the other hand, FA-A closer to the point of impact has higher deformation than FA-B in case 2. The deformation of upper area (i.e., d6, d8) is higher than lower area (i.e., d5, d7) in horizontal measurement regions because the center of gravity is positioned higher than the cradle assembly. So, the shipping container rotates slightly along the longitudinal direction and then

Table 3. Deformation of confinement system for each case

Case	d1	d2	d3	d4	d5	d6	d7	d8	d9
1	3.1	3.9	4.8	3.2	0.9	1.6	0.7	0.9	0.1
2	5.2	3.5	1.5	0.9	2.3	4.2	0.8	1.4	-0.7
3	5.5	6.2	8.0	7.3	3.0	5.0	1.7	2.5	-0.2

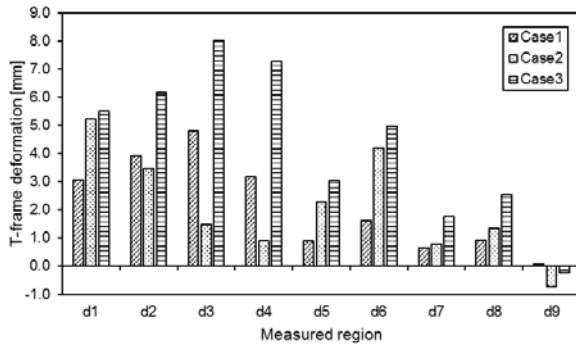

Fig. 9. Measured deformation of confinement for each case

is more shocked in the upper region in the second impact. Case 3 has higher deformation than others because the rectangular tubes which is a component of lid assembly do not support the behavior of fuel assemblies properly compared with other cases. The rectangular tubes are deformed and then absorb some impact energy. The distances at d9 in case 2 and 3 show the negative value and it means that the distance is decreased. The distance for most measurement regions are increased because these are a little away from the impact area and the shipping container is deflected along whole length, so the cross-sections of measured regions were expanded.

5 Conclusion

In this study, the effect of drop orientation on behavior characteristics of shipping container was considered. The analytical evaluations of the shipping container for the nuclear fresh fuel were performed in accordance with the regulatory requirements. The finite element model of the shipping container was developed for 9 m free drop conditions. The material properties were applied to the analysis model to predict the nonlinear transient behavior. Three types of drop orientations were considered to study the free drop characteristics of shipping container. Explicit transient analyses were performed using LS-DYNA program and some conclusions were derived in this process.

- The reaction force is related to the total acceleration.

- A significant impact energy is absorbed by the polyurethane foams and shock absorbers.
- The acceleration and reaction force are for the evaluation of containment system.
- The highest total acceleration and reaction force are occurred in case 1. As a result, case 1 is the drop orientation that has the greatest effect on containment system.
- The deformation of internal assembly is for the evaluation of confinement system.
- The highest deformation of internal assembly is occurred in case 3. As a result, case 3 is the drop orientation that has the greatest effect on confinement system.

The analysis results will be verified through comparison with the test results in the following study. The finite element model and the analysis results can be applicable to the container design modification and the shipping container development.

References

1. S. P. Ryu, J. H. Chun, J. J. Lee, N. G. Park, W. C. Hwang, GLOBAL2017 International Nuclear Fuel Cycle Conference, *The analytical evaluation of a PIONEER G nuclear fuel container based on the design requirements* (2017)
2. US NRC, 10CFR71, *Packaging and transportation of radioactive material* (2016)
3. MOSF, NSSC Notice 2017-56, *Guidelines for application of korea electric power industry code (KEPCI) as technical standards of nuclear reactor facilities* (2017)
4. IAEA, SSR-6, *Regulations for the safe transport of radioactive material* (2012)
5. LSTC, *LS-DYNA user's manual* (2007)
6. ASME, Section II Part D, *ASME boiler and pressure vessel code properties (metric)* (2013)
7. J. W. Straight, LA-8081-MS, *Nuclear shipping container secondary impact analysis*, Los Alamos Scientific Laboratory (1979)