

Improving quality of ac electric power supply of autonomous power sources using in agriculture

Olga Milashkina^{1,*} and *Vadim Zlobin*²

¹Ulyanovsk Institute of Civil Aviation named after Chief Air Marshal V.P. Bougayev, Ulyanovsk, Russia,

²Ulyanovsk State Agrarian University named after P. A. Stolypin, Ulyanovsk, Russia.

Abstract. Autonomous AC electricity supply systems are now widely introduced in agriculture. As the experience of operation of these electricity supply systems has shown, their various properties, determined largely by the type of voltage regulators and sensors used, do not always fully meet the constantly growing requirements for the quality of electricity. Further improvement of voltage regulation systems, and, consequently, the quality of electricity, is associated with the use of technology in them that can implement optimal control laws.

1 Introduction

The problem of electricity quality is closely related to the reliability and durability of various types of loads, moreover, particularly demanding loads can only function with high voltage quality. Long-term increase or decrease in the supply network voltage leads to a reduction in the service life of supply sources.

Today, it is most economically advantageous to use electricity quality correction devices with the help of regulators or sensors for one or more electricity quality indicators or related parameters of power consumers. Changes to the network structure or updates to all consumers lead to significant costs. Of course, the design of new networks and consumers must be carried out according to modern requirements, but in order to make reliable operation of already existing equipment, it is necessary to develop electricity quality regulators of various types and sensors of voltage non symmetric.

It is proposed to solve the issues of improvement of electric power quality indices of prospective power supply systems by means of implementation of optimal laws of voltage regulation in the system of AC generation with synchronous generator at application of voltage non-symmetric sensor with connection of additional capacitive resistance to the network.

* Corresponding author: milashkina.o@mail.ru

2 Main part

A nonlinear mathematical model of a synchronous generator has been developed in a MatLab environment and its adequacy to a real object has been proven; the efficiency of the voltage non-symmetric sensor under different modes of generator operation [1] compared to the current GOST 32144-2013 was analysed.

The results of the study of emergency modes in the electric power system, which showed ways for further extension of the possibility of diagnosing electric power systems, were obtained in the work.

The results of the study of voltage change properties in the system of AC generation with synchronous generator on the complex mathematical model (Fig. 1), developed in the Simulink application of the engineering programming environment MatLab in the mode of asymmetric load with the use of a non-voltage sensor [1,2] (Fig. 2) and with the connection of additional capacitive resistance to the network, are presented.

In the complex mathematical model of the AC generation system feedback on speed and voltage is organized, the operation of the excitation system of the synchronous generator [1,2] is considered. With the help of the developed models in different modes in the application MatLab -Simulink, oscillograms of transient processes of voltage of the AC generation system network, main characteristics of the synchronous machine with the use of a voltage non-simmetry sensor with connection of additional capacitive resistance to the network were obtained.

The voltage asymmetry sensor of a three-phase source (a. s. 19340) is shown in Fig. 2, which relates to the field of electrical engineering, to devices for measuring voltage asymmetry in power supply system

For the purpose of simplification, in the device one of the output signals of said sensor is formed by pairwise summing two other output signals thereof. Mathematically, the specified operation is described by the following expressions:

$$\mu 1 = (+U_{a\theta}) + (-U_{bc}) ; \quad (1)$$

$$\mu 2 = (+U_{a\theta}) + (-U_{ca}) ; \quad (2)$$

$$\mu 3 = -(\mu 1 + \mu 2) . \quad (3)$$

As a result, it is possible to reduce the number of diodes, resistors and potentiometers in comaparement to other devices for measuring voltage asymmetry of power supply systems. The purpose of working with this device is to simplify the voltage asymmetry sensor and reduce its weight and size indices

In the known device measuring transformers are equipped with two additional secondary windings, the number of turns of which is twice less than the number of turns of the main secondary windings, at the same time additional secondary windings of different transformers are connected in pairs in series and according to the obtained connections of windings one pair of different-named leads are connected to a common tire, and the other pair of different-named leads are connected to inputs of one of rectifiers.

In this device, it is possible to obtain information on all three linear voltages of the source using only two measuring transformers. At the same time each additional winding of measuring transformers in the form of two sections with equal numbers of turns, pairwise sequential connection of sections of different measuring transformers with subsequent connection of one pair of different terminals of the specified connections of the sections to the common point of the sensor circuit, and the other pair of different terminals - to inputs of one of rectifiers, which allows to formulate non-measured linear voltage of the source. This voltage is formed in the form of two different components, which provides for obtaining a middle point in connections of windings from which the specified voltage is

removed (middle points of secondary windings form a common point of the sensor circuit, relative to which output signals of the sensor are removed). Circuits are known for generating three linear source voltages based on two measuring transformers in electrical engineering, the most common of which is the Scott circuit.

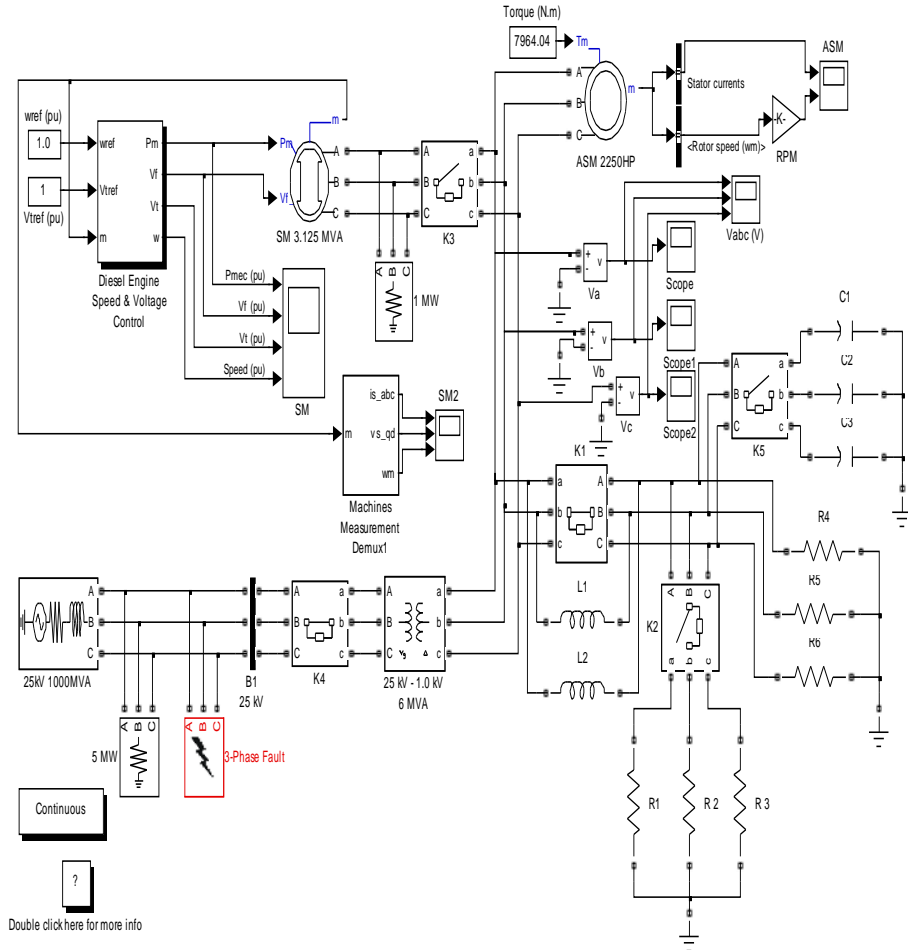

Fig. 1. Diagram of the stand-alone power supply model with additional capacitive resistance connected to the syste ofm

Three-phase source voltage of unbalanced sensor has two measuring transformers 1 and 2, primary windings which are connected to the phases of 3-5 source. Main secondary windings 6 and 7 of measuring transformers are connected to the rectifiers 8 and 9. Additional secondary windings of the different measuring transformers 10 and 11, 12 and 13 are connected in pairs in the series. At the obtained connections of an additional secondary windings one pair of the different-named leads is connected to a common point of circuit 14, and the other pair of the different-named leads is connected to the inputs of the rectifier 15. The middle points of the main secondary windings of the measuring transformers are connected to the common point of the circuit. Potentiometers 16 - 19 and 20 are connected to the output different-name terminals of adjacent rectifiers by means of a limiting resistors 21. The input of filtering element 22 and one of the inputs of summing element 23 are connected to the engine of one potentiometer. The slider of the other potentiometer is connected to the second input of the above summing element and to the

input of the filtering element 24. The outputs of the filtering and summing elements are 25 - 27 outputs of the sensor.

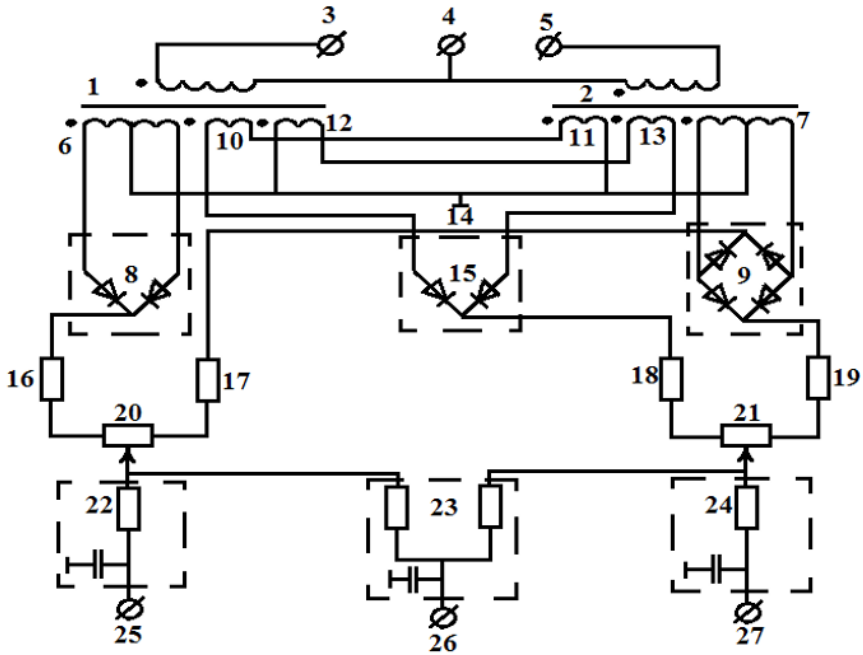

Fig. 2. Schematic diagram of the sensor of asymmetry of tension three-phase source

The work of the device is going like this. Two linear voltages of three-phase source U_{3-4} and U_{4-5} are supplied to primary windings of measuring transformers 1 and 2. The third linear voltage required to obtain signals carrying information on the degree of non-symmetry of the source voltages is formed by adding its other two linear voltages measured directly. At the same time for receiving an average point in the scheme of formation of linear tension U_{3-5} each measuring transformer is equipped with two additional secondary windings (windings 10, 12 and 11, 13) each number of rounds is twice less than number of rounds of the main secondary windings. These additional secondary windings connected in pairs in series make it possible to generate U_{3-5} voltage with the output of middle point. Middle points of secondary windings of measuring transformers are connected and form common tire 14 of sensor, relative to each its output signals are removed. Further the signals bearing information on the linear tension of U_{3-4} , U_{4-5} , and U_{3-5} by means of restrictive resistors 16-19 arrive on potentiometers 20 - 21.

Two output signals of a sensor are obtained as a result of filtering signals removed from engines of specified potentiometers. The third sensor output is generated by summing the signals output from the potentiometers 20, 21 and filtering them.

Three-phase source voltage non-symmetric sensor comprising measuring transformers; rectifiers connected to the secondary windings of measuring transformers; potentiometers, extreme conclusions which are connected through resistors to the opposite conclusions of neighboring rectifiers; filter elements whose outputs are the outputs of the sensor; a summing element, each input of which is connected to the input of one of the filter elements, and the output is the output of the sensor, characterized in that the measuring transformer has two additional secondary windings, the number of turns of which is two times less than the number of turns of main secondary windings and auxiliary secondary windings of different transformers are connected in series in pairs and in accordance with,

and the resulting connections of windings one pair of opposite conclusions connected to the shared bus, and the other pair of opposite conclusions is connected to the inputs of one of the rectifiers.

The presented study was carried out with a synchronous AC generator using a voltage nessesymmetric sensor with an additional capacitive resistance connected to the network, where the use of additional capacitances allows to improve characteristics of the diesel generator.

Figure 3-5 show the oscillograms of the voltage of the network with synchronous AC generator when using the voltage non-symmetric sensor with an additional capacitive resistance connected to the network

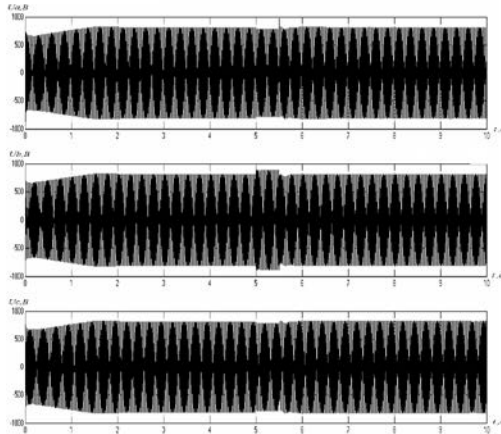

Fig. 3. Network voltage oscillograms with the synchronous generator

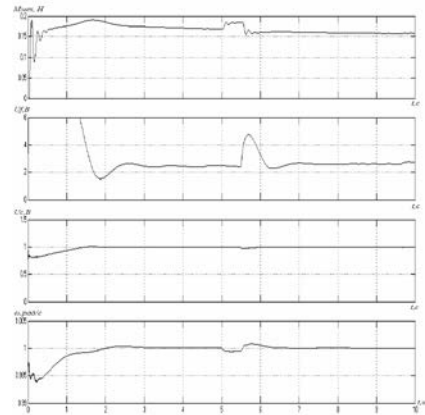

Fig. 4. Oscillograms of the main characteristics of the generator (M_{mx} moment on the shaft of synchronous generator, angular frequency and voltage change by frequency and time).

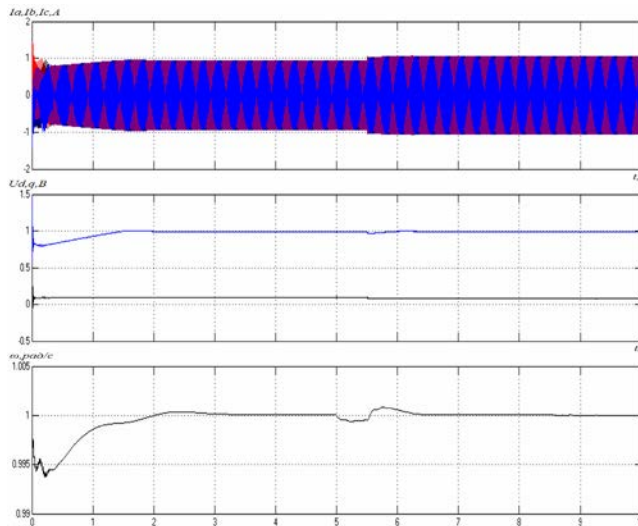

Fig. 5. Oscillograms of synchronous machine (currents in phases, voltage and angular frequency)

Let's analyse the received oscillograms. In Figure 3 there is no such voltage failure in phase C, acceleration and re-adjustment time is reduced both at acceleration and at activation of balancing device. Most importantly, as we can see from the oscillograms (Fig. 3-5), the stator currents of the generator are significantly smaller than in the experiment without introducing additional capacitive resistance. All this shows that the use of the additional tanks allows not only to improve the quality of electricity, but also to significantly improve the characteristics of the diesel generator itself. And the non-symmetric sensor significantly improves the electric quality of the autonomous power supply. At the moment when the asymmetric load is switched on, the speed of rotation of the synchronous generator falls, but due to the organized feedback on speed its value is equalized, and at the time of switching on the non-symmetric sensor the process of speed re-adjustment takes place, as well as reduces the load on the generator in such mode of its operation, which allows to avoid unnecessary overloads.

Inference. The results of the conducted studies, the developed voltage control system of the power generation channel with synchronous generator at application of the voltage non-symmetric sensor with connection to the network of additional capacitive resistance for improvement of electric power quality of the AC generation system show efficiency of the given system and with its help reduces limits of normal transient voltages. That will undoubtedly have a positive impact on improving the reliability of the receivers and improving the quality of the produced energy of the AIP used in agriculture. Thus, providing an improvement in the quality of electric power, both in the amount of re-regulation and time of transient processes and in the amount of static error, will undoubtedly have a positive impact on the reliability of the electric power receivers.

References

1. O.V Milashkina, *Improvement of the quality of electric power generated by autonomous diesel-generator plants*, dis. per search. Article k.t.n to, **special 05/09/03 Electrical complexes and systems, 2010.**
2. O.V. Milashkina, M.A. Borovikov, B.Bystritsky, *Voltage nessymmetry sensor of three-terminal source*, AMPERE-SECOND. NO. 19340, RUSSIAN FEDERATION, Büll.Invention. **Useful models. - № 8. _ 2001.**