

# Theoretical study of the forced oscillation effect on subsoil tillage

Ivan Masienko<sup>1,\*</sup>, Artem Vasilenko<sup>1</sup>, and Lyudmila Eranova<sup>1</sup>

<sup>1</sup>Kuban State Agrarian University named after I.T. Trubilin, Krasnodar, Russia, 350044

**Abstract.** The work presents a tillage machine with vibrational electronic elements mounted on the working bodies, which allow reciprocal oscillating movements of the chisel bit and duckfoot shovels. Theoretical studies of the dependence of traction resistance reduction of a tillage machine on the influence of oscillations of the working bodies on the soil and on the unit's speed. The oscillating movements of the working bodies will improve the quality of the main processing of heavy soils in gardens, reduce the energy intensity of a given process and increase productivity by increasing the unit's speed.

Recently, the use of various vibrational and impulse working organs has become most widespread in the designs of agricultural machinery. Agricultural machines with vibrating tools are much more economical and productive than machines with classic tools.

The main use of vibration of the working bodies of machines is aimed at the implementation of main tillage in gardens. This technological operation in the cultivation of many horticultural crops is the most material and energy-intensive compared to other operations in the adopted technology.

With the help of vibrating working bodies, it is possible to perform the operations of the main tillage in gardens under conditions in which machines cannot cope with the constantly acting efforts of the working bodies [1].

When using the most effective means to reduce costs to produce horticultural products, the use of combined high-performance machines in the designs of which it is also desirable to introduce working bodies with vibrational pathogeners are used more and more often. However, it is necessary to most fully study the effect of vibration on lowering the traction resistance of a machine, which should reflect on the development of new directions in the development of designs of agricultural machines with vibrating working bodies.

The developed technical device has several new design solutions that differ significantly from previous designs. In the design, a stand is added with a circular guide installed in the lower part. A chisel bit is installed on the guide. In addition, we fix the solenoid in the housing to the rack of the working body with screws. The solenoid is made in the form of a coil with a spring and a striker.

The design of duckfoot shovels has also been finalized, now they are fixed immovably in the bracket of the horizontal plane.

---

\* Corresponding author: [ivan.masienko@yandex.ru](mailto:ivan.masienko@yandex.ru)

The modernization of the working bodies' design of the tillage machine will allow reciprocal movements of the chisel bit and duckfoot shovels.

The striker in the process of vibration of the electronic element constantly interacts with the chisel bit, thereby providing small-amplitude perturbations. This property of the working bodies will improve the quality of the soil cultivation operation in gardens and will lead to a decrease in the energy intensity of a given process.

Figure 1 shows a diagram of the forces acting on the developed specialized tillage machine with a vibrating electronic element of directional action for work in the garden aisles.

Constant mobility of the working bodies of a specialized tillage machine is provided by a vibrating electronic element of directional action. The solenoid shaft creates disturbing force  $F$  and leads the working bodies to vibration, during which reciprocal movements are made along the movement of the unit. The working bodies of the tillage machine make oscillating movements in the vertical and horizontal planes with amplitudes  $A_x$  and  $A_y$  [2].

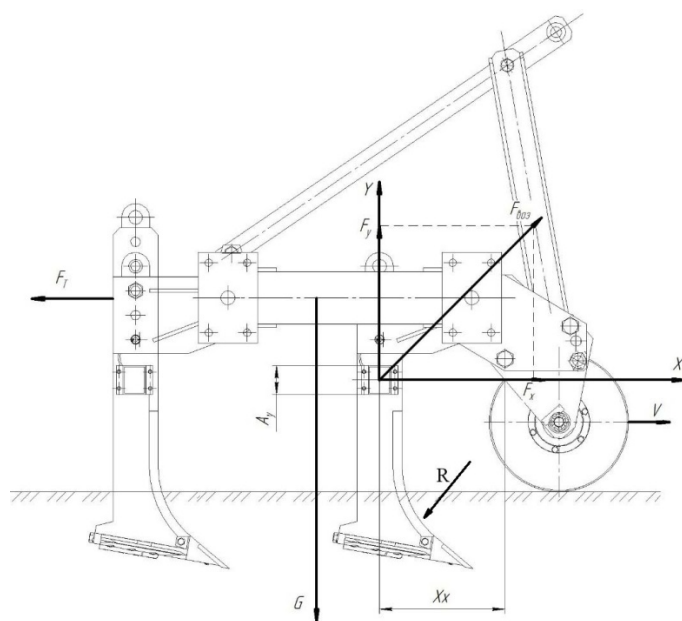

$F_x$  - disturbing force in the horizontal plane;  $F$  - disturbing force;  $R$  - force of action of the working body;  $F_y$  - disturbing force in the vertical plane;  $G$  - tillage machine weight;  $A_x$ ,  $A_y$  - amplitude of oscillations in horizontal and vertical planes;  $V$  - direction of movement of the tillage machine

**Fig. 1.** Diagram of forces acting on a specialized tillage machine with a vibrating electronic element mounted on working bodies

We will consider the working process only for steady forced oscillations of the working bodies. This is since over time, the own oscillations of the working bodies of the tillage machine, depending on the initial conditions, quickly taper out.

When performing the technological process of the main tillage, the vibrating working bodies actively interact with heavy soil between the rows of gardens across the entire depth of the cultivated layer. As a result, there is a softening of the soil under the influence of normal loads.

When the working body moves, vertical and horizontal loads arise. The working bodies of the machine for soil processing in the process of performing a technological operation are not removed from the soil to ensure the lowest energy loss.

To determine the main reactions, we accept that the stand and the frame of the working bodies with a vibrating electronic element are rigid structures and deformations do not arise in them. The working bodies oscillate strictly in the horizontal and vertical planes, therefore we neglect the angular oscillations in the longitudinal plane. To exclude unnecessary vertical oscillations due to field irregularities, we take the surface of the cultivated soil as flat [4].

Let us determine the value of soil resistance given its rheological model (Figure 2). To do this, we bring to point O the working bodies of an agricultural tillage machine.

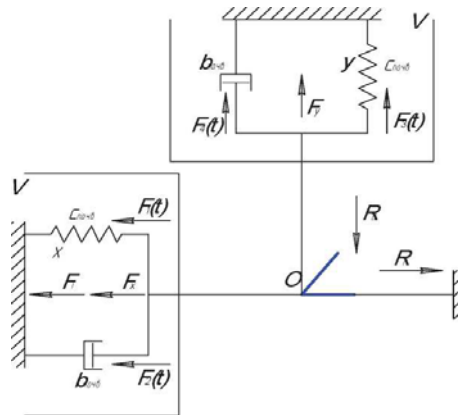

V – soil volume;  $b_{\text{пoчбм}}$  - viscosity element;  $C_{\text{пoчб}}$  – elastic element

**Fig. 2.** The diagram of excitation of oscillations of the working bodies of a tillage tool with a vibrating electronic element

The working body of the tillage machine for working in gardens is made in the form of a plane-cutting shovel, acting on the soil volume through point O in vertical and horizontal planes. In the construction, we will take into account that the action force of the working body R on the soil will be spent on the deformation of the elastic  $C_{\text{пoчбм}}$  and the viscous  $b_{\text{пoчбм}}$  of its elements. Then, the action force of the working body on the soil, causing resistance of the soil volume  $R_r$  and  $R_B$ , is determined considering the following expression:

$$R_r = n (F_1(t) + F_2(t)) + F_T - F_x, \quad (1)$$

$$R_B = n (F_3(t) + F_4(t)) - F_y, \quad (2)$$

where  $F_x, F_y$  - the amplitude value of the disturbing force relative to axes X and Y;

$F_1, F_3$  - forces spent on overcoming the elastic resistance of the soil, H;  $F_2, F_4$  - force spent to overcome the viscous resistance of the soil, H;

G - tillage machine weight, H;

$F_T$  - pull resistance of a tillage machine, H;

n - the number of working bodies of the tillage machine, pcs;

f - coefficient of resistance to movement of a tillage machine.

Let us determine the pull resistance of a tillage machine with a vibrating electronic element using the expression

$$F_T = (G - F_y) f, \quad (3)$$

Then we will determine the amplitude value of the perturbing force relative to the horizontal axis X and the vertical axis Y using the expression:

$$F_x = 2m4\pi^2v^2x\sin 2\pi vt, \quad (4)$$

$$F_y = 2m4\pi^2v^2ycos2\pi vt , \quad (5)$$

where  $m$  - the mass of the rod, which is installed in the solenoid, kg;

$x$  - the amplitude of the rod's oscillations, m;

$v$  - rod oscillation frequency, rad/s;

$t$  - rod oscillation time, s;

Effect of the vibrating working body of the tillage tool on the soil layer in gardens causes crushing and shift of soil particles. The movement of point O of the contact of the working body with the soil will consist of a movement in the direction of  $x$  and  $y$  axes and will take the form of the following expression [5].

$$x = V_{\Gamma} t , \quad (6)$$

$$y = V_B t , \quad (7)$$

where  $V_{\Gamma}$  – the speed of moving point O of the contact of the working body with the soil in a horizontal plane m/s.

$V_B$  – the speed of moving point O of the contact of the working body with the soil in a vertical plane, m/s.

Let us determine the movement of  $x$  and  $y$  from the following expression [3]:

$$x = \frac{F_1(t)}{C_{пoчвbы}} , \quad (8)$$

$$y = \frac{F_3(t)}{C_{пoчвbы}} , \quad (9)$$

where  $C_{пoчвbы}$  – the soil elasticity element

Let us put the values of displacements  $x$  and  $y$  in the equations (3.6 - 3.9):

$$V_{\Gamma} t = \frac{F_1(t)}{C_{пoчвbы}} , \quad (10)$$

$$V_B t = \frac{F_3(t)}{C_{пoчвbы}} , \quad (11)$$

After solving equations (10) and (11), we will obtain an expression for determining the forces spent on overcoming the elastic resistance of the soil:

$$F_1 = V_{\Gamma} C_{пoчвbы} t , \quad (12)$$

$$F_3 = V_B C_{пoчвbы} t , \quad (13)$$

The forces spent on overcoming the viscous resistance of the soil,  $F_2$  and  $F_4$  are determined through  $b_{пoчвbы}$  with the help of the expression proposed by S.P. Tymoshenko[3]

$$F_2 = b_{пoчвbы} V_{\Gamma} , \quad (14)$$

$$F_4 = b_{пoчвbы} V_B , \quad (15)$$

where  $b_{пoчвbы}$  – the soil viscosity element.

Assuming the same physical and mechanical properties due to the small distance between the particles in contact with point O of the soil, we will take the elastic  $C_{пoчвbы}$  and the viscous  $B_{пoчвbы}$  making up the soil in the vertical and horizontal planes as equal. After replacing  $C_{пoчвbы} \cdot t$  product with the dynamic viscosity of the soil layer  $\mu$ , we will derive the dynamic viscosity formula:

$$\mu = \nu\rho , \quad (16)$$

where  $\nu$  - the kinematic viscosity of the soil layer,  $m^2/s$ ;

$\rho$  - density of the treated soil layer,  $kg/m^3$ .

Let us determine the density of the soil using the following expression:

$$\rho = \frac{m_{\text{почвы}}}{V}, \quad (17)$$

where  $m_{\text{почвы}}$  - soil mass in the treated layer, kg.

The volume of the treated soil layer by the working bodies of the tillage machine is determined using the expression [6]:

$$V = Sa, \quad (18)$$

where  $S$  - soil layer area  $\text{m}^2$ ;

$a$  - the average depth of soil treatment by the working bodies of the machine, m.

Then the expression for determining the forces spent on overcoming the elastic resistance of the soil layer will be as follows:

$$F_1 = \frac{V_{\Gamma} v m_{\text{почвы}}}{S a}, \quad (19)$$

$$F_3 = \frac{V_B v m_{\text{почвы}}}{S a}, \quad (20)$$

When the working bodies of the tillage machine only produce oscillations, the impact speed for determining the residual displacement is taken according to the works by S.N. Drozdov [1].

Then the expression for determining the movement speed of point O of the contact of the tillage machine working body with the soil layer in the vertical plane is written in the following form:

$$V_B = \sigma_{nu} \sqrt{\frac{g}{E\gamma}}, \quad (21)$$

where  $\sigma_{nu}$  - limit of proportionality of the soil layer, Pa

$\gamma$  - specific gravity of the soil layer,  $\text{N/m}^3$ .

$E$  - modulus of elasticity of the soil layer under tension and compression, Pa;

Having substituted the obtained data into expressions (1) and (2), we will derive the equation for determining the movement speed of point O of the soil contact with the vibrating working body of the tillage machine in the vertical and horizontal planes [7, 8]:

$$R_{\Gamma} = nV_{\Gamma} \left( \frac{v m_{\text{почвы}}}{S a} + b_{\text{почвы}} \right) + (G - 2mr\omega^2 \cos\alpha) f - 2mr\omega^2 \sin\alpha, \quad (22)$$

$$R_B = n\sigma_{nu} \sqrt{\frac{g}{E\gamma}} \left( \frac{v m_{\text{почвы}}}{S a} + b_{\text{почвы}} \right) - 2mr\omega^2 \cos\alpha, \quad (23)$$

The final value of the resulting traction resistance of the tillage machine is determined by the expression

$$R = \sqrt{R_{\Gamma}^2 + R_B^2}, \quad (24)$$

The results of the derived equations (22) and (23) will be presented in Figure 3, on which the curves of the traction resistance of a horticultural machine without a vibrating electronic element and with it at different speeds of the unit are plotted.

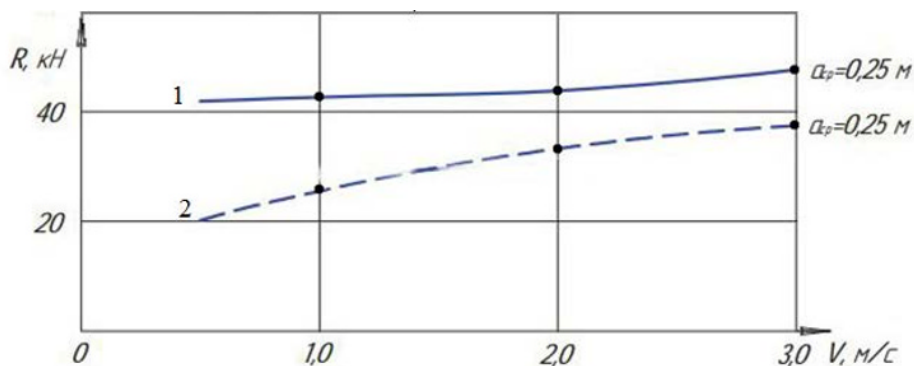

1 – the theoretical curve of traction resistance of a tillage machine without a vibrating electronic element; 2 - the theoretical curve of traction resistance of a tillage machine with a vibrating electronic element;

**Fig. 3.** Dependence of traction resistance of the tillage machine working bodies on the movement speed

Analyzing the results of theoretical studies, we can conclude that when a vibrating electronic element is installed on the working bodies, the traction resistance of the tillage machine will significantly decrease, which will improve the quality of the main processing of heavy soils and increase its productivity by increasing the speed of the unit.

The use of working bodies with a vibrating electronic element of directed action is most appropriate in the design of agricultural machines used in the main processing of heavy soils in the aisles of gardens.

## References

1. S. Drozdov, Use of vibration in tillage machines. *Izvestija Orenburgskogo gosudarstvennogo agrarnogo universiteta* [News of Orenburg State Agrarian University], 32, pp. 20-23, (2011)
2. V. Konovalov, Analytical study of the design parameters of the grinding unit of disk harrows, V. Konovalov, S. Konovalov, V. Igumnova, *IOP Conference Series: Earth and Environmental Science*, **403**, 012086, (2019)
3. S. Drozdov, Use of forced vibrations to reduce traction resistance of tillage machines, *Izvestija Orenburgskogo gosudarstvennogo agrarnogo universiteta* [News of Orenburg State Agrarian University], 1, pp. 34-39, (2013)
4. V. Vasilenko, D. Afonichev, Effect of vibration on the angle of soil friction according to the working tool, *Sankt-Peterburgskij gosudarstvennyj lesotekhnicheskij universitet* [St. Petersburg State Forestry University], 3, pp. 123-126, (2013)
5. S. Papusha, Interaction of rotary working body of roller type with the object of processing, Sergey K. Papusha S, Azamat E. Bogus, Vladimir I. Konovalov, *MATEC Web of Conferences*, **224**, 05007, (2018)
6. V. Konovalov, Constructive-technological diagram of the rotary-string cultivator and the definition of its main parameters, V. Konovalov, S. Konovalov, V. Igumnova, *E3S Web of Conferences*, **126**, 00039, (2019)
7. I. Masienko, Development prospects of mobile rice straw crushers, In the collection of papers *E3S Web of Conferences*, c. 00022, (2019)
8. V. Karpenko, Innovation process of machine harvesting of laid peas and its efficiency, Karpenko V., Masienko I., Eranova L.B, In the collection of papers *E3S Web of Conferences*, c. 00021, (2019)