

Development of environmental protection system for installation of chrome plating of the internal surfaces of hydraulic drives with hydrostatic guideways

Dmitrii Ardashev¹, Nizami Yusubov², Leonid Shipulin^{1,}, and Anastasiya Degtyareva-Kashutina¹*

¹South Ural State University, 76 Lenina Ave., Chelyabinsk, the Russian Federation, 454080

²Azerbaijan Technical University, 25 H. Javid Ave., Baku, Azerbaijan, 1073

Abstract. Electroplating is an electrochemical process when a metal layer is deposited on the surfaces of a product. As an electrolyte, a solution of the salts of the deposited metal is used, the vaporization and micro-spray of which have an extremely negative and dangerous effect on humans and the environment. In this work, we present an environmental protection system for implementing the process of chrome plating of the internal surfaces of a hydraulic drive with hydrostatic guideways is presented. The schematic diagram of the environmental protection system includes the first stage of air purification (drip collector), the second stage of air purification (granular filter), as well as a system of granular filter cleaning and a radial fan. To clean the exhaust air from harmful substances, such as aerosols of chromium oxides and sulfuric acid, as well as water vapor, a comprehensive gas purification system for emissions of pollutants is proposed, consisting of step-by-step cleaning in various devices, including a drip collector with two droplet-breaking elements and a granular filter. The presented design of the environmental protection system equipment of the installation for chrome-plating the internal surfaces of a hydraulic drive with hydrostatic guideways will make it possible to effectively neutralize the air environment by cleaning the air from chrome anhydride vapor and other pollutants.

1 Introduction

Electroplating is an electrochemical process in which a metal layer is deposited on the surfaces of a product. In this case, a solution of salts of the deposited metal is used as an electrolyte. Production conditions of galvanic sections are characterized by increased humidity, a significant concentration of harmful vapors and gases, dispersed mists and electrolyte sprays [1].

The existing general sanitary and hygienic standards establish requirements for the permissible content of harmful substances in the air of the work zone and workplaces.

* Corresponding author: shipulinlv@susu.ru

According to GOST 12.1.005–88 ‘General Sanitary and Hygienic Requirements for the Air in the Working Area’, the content of harmful substances in the air of the working area must not exceed the maximum permissible concentrations (MPC) used in the design of industrial buildings, technological processes, equipment, ventilation, for monitoring the quality of the working environment and the prevention of adverse effects on the health of workers. Thus, the maximum permissible concentration of chromic anhydride in the air of the working area is 0.01 mg/m^3 , and in the atmospheric air of populated areas 0.0015 mg/m^3 . The maximum permissible concentration of single sulfuric acid in the air of the working area is 1 mg/m^3 , and in the atmospheric air of populated areas - 0.03 mg/m^3 , the average daily - 0.1 mg/m^3 .

Cleaning industrial emissions is of great sanitary and hygienic importance in terms of environmental regulation and is one of the measures to protect jobs and atmospheric air in populated areas from harmful substances and impurities. The choice of the design of gas purification equipment and the technology of purification used is carried out depending on the nature of the production process, the composition of the gases formed, the required degree of purification, and other parameters.

2 Existing technical solutions to protect the environment when applying chromium plating

The main measures ensuring the maintenance of regulatory requirements for the working area air conditioning is creation of combined extract and input ventilation, which allows by exchanging air (suction the contaminated and supplying the fresh) to keep the content of harmful substances in the room air at a level that does not exceed sanitary norms.

The extract and input ventilation of industrial premises removes dirty air while supplying fresh air masses, while the distribution of flows can occur due to mixing or displacement [2].

Currently, ventilation hoods can be used as ventilation systems in galvanic workshops with some technological equipment inside; extraction canopies (caps) installed above the technological equipment and above the electroflotators; suction grills installed on the side of the equipment on its non-working side; side suction mounted at the top of the plating baths and surface treatment plants.

The ventilation hood isolates the room from harmful emissions from installations located inside the hood but makes access to the equipment difficult. The extraction canopy is easy to manufacture, but when using it, air consumption is high, since it is difficult to avoid air suction from the sides. The local suction device affects not only the ventilation efficiency, but also the performance of the galvanic process. The slot hoods can be manufactured separately or together with a plating bath. According to S.S. Vinogradov, slot hoods remove drops and heavy and light gases well [3]. However, the use of slot hoods increases the width of the equipment and, as a result, the local ventilation area.

The operation principle of a ventilation exhaust is that the air drawn in through a narrow intake slit forms a strong horizontal jet above the solution mirror, knocking down gases and drops coming from the solution from the vertical direction, which causes a significant mass of drops to fall back into the bath, and the remaining drops and gases are carried away to the exhaust. As you move away from the intake gap, the energy of the air stream rapidly decreases, as a result of which it is recommended to do one-way exhaust with a bath width of up to about 600 mm. On wider baths, exhausts are made from two opposite sides of the bath.

In systems of slot devices, it may be possible to install an individual filter for air purification. Also, the removal of harmful substances is performed in the general ventilation system [3, 4].

One of the methods for cleaning exhaust aerosols during galvanic treatment is the local cleaning of aerosols using drip collectors. Drip collectors are designed to separate liquid droplets from the gas stream and are apparatuses in which the trapped liquid does not accumulate but is immediately discharged into a lower container. The choice of a drip collector design mainly depends on the size of the droplets trapped.

In the devices for separation of droplet entrainment, inertial and centrifugal precipitation of liquid droplets is most often used. Inertial mist eliminators use various nozzles installed at the outlet of the gas stream from the apparatus, in the form of a layer 80–200 mm high from Rashig, Pall, Berl rings, rods (Carbait separator), fine nets, fibers, as well as ordinary mass transfer plates [5– 7].

To clean the gases from fog, you can also use traditional dust collecting devices - a nozzle scrubber, a Venturi scrubber, an electrostatic precipitator, etc. [8–11]

Another method of cleaning aerosol emissions from galvanic production is filters of various designs. The filtering partitions through which the air is filtered are different in structure, but mainly consist of fibrous or granular elements - fabric materials from natural, synthetic or mineral fibers; nonwoven fibrous materials (felts, glued and needle-punched materials, paper, cardboard, fibrous mats); cellular sheets (sponge rubber, polyurethane foam, membrane filters) [12–15].

3 Schematic diagram of the environmental protection system of the installation for chromium plating

Within the framework of the project ‘Creation of a high-tech production of hydraulic drives with a wide range of hydrostatic guideways with low resistance to movement of moving parts and an increased resource for bench test equipment’, with the financial support of the Russian Ministry of Education and Science, a schematic diagram of an environmental protection system for conducting the process of chrome coating on the internal surfaces of hydraulic drives has been developed with hydrostatic guideways. Fig. 1 shows a schematic diagram of a two-stage environmental protection system being developed for a chrome coating installation on the inner surfaces of a hydraulic drive with hydrostatic guideways.

The installation (2) for chrome plating the inner surface of the part (1) includes an electrolyte tank, two pumps supplying the electrolyte to the cavity of the part, which swirls to the upper part of the workpiece and merges into the central rod and returns to the tank. From above, the workpiece is pressed by a plate made of plexiglass resistant to electrolyte and a steel plate by tightening the side nuts [16].

The environmental protection system includes: the first stage of air purification - a drip collector (3), the second stage of air purification - a granular filter (4), the purification system of a granular filter (5) and a radial fan (6).

The first stage of purification is a drip collector (3), designed primarily to remove aerosol of chromic anhydride and residual water vapor [17]. The drip collector contains a housing with inlet, outlet and drain pipes and two drop-off elements installed coaxially in the housing, while the housing is made in the form of connected cylinders of different diameters: inlet pipes for cleaned mixtures are arranged at an angle (tangential) to the housing apparatus for creating additional swirling flow. At the same time, a drain pipe is made in the bottom of the upper wider cylindrical part, through grooves are made in the upper cylindrical part of the housing at the place of installation of the drop-off elements. Drop-off elements are made in the form of a disk with elliptical tangential holes of small and large sizes, directed from the periphery to the center, from top to bottom, evenly spaced along two circles of smaller and larger diameters, respectively. The design of drop-off elements in the form of a disk with elliptical tangential openings ensures elimination of

dropping liquid from the gas stream due to centrifugal forces at the periphery of the stream, thereby separating liquid droplets from gas.

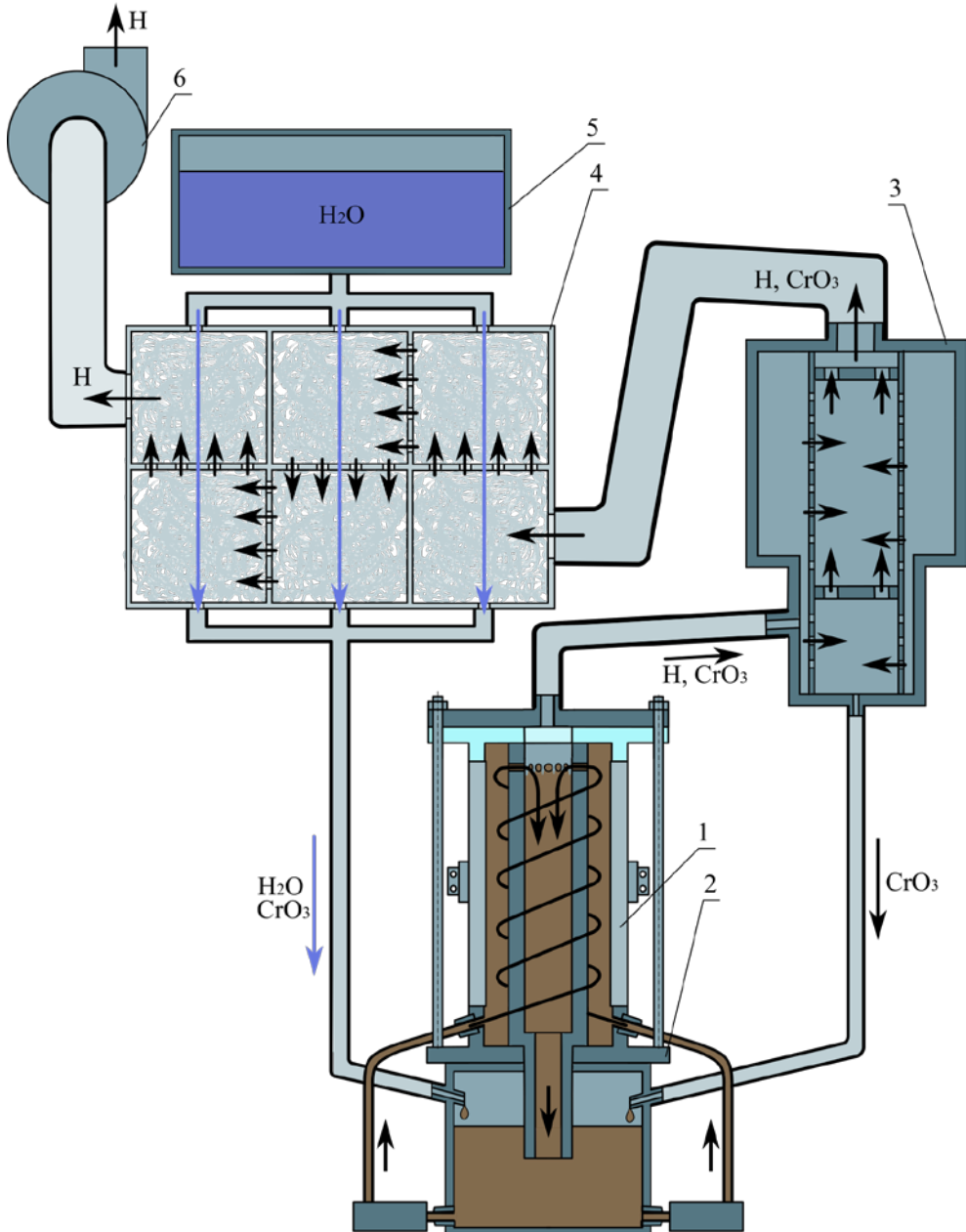

Fig. 1. Installation for chrome-plating the internal surfaces of hydraulic drives with hydrostatic guideways and an environmental protection system, including: 1 - chrome-plated part, 2 - installation for chrome-plating, including a tank and two pumps, 3 - the first stage of air purification (drip collector), 4 - the second stage of air purification (granular filter), 5 - granular filter cleaning system, 6 - radial fan.



Fig. 2. The first stage of the environmental protection system is a drip collector: on the left is its appearance, on the right are its components and drop-off elements.

The second stage of protection is a granular filter (5) for finer purification of exhaust gases from chrome anhydride vapors and other pollutants. The principle of the filter operation is to pass a stream of contaminated gas through the filter layer of granular materials made of acid-resistant materials, for example, fluoroplastic, of various sizes. The cleaning efficiency increases with decreasing grain diameter in the layer and increasing layer resistance. The gas flow is supposed to be directed through packets of granular materials of various sizes, starting with particles of larger diameter and ending with the smallest (6 chambers with different particle diameters). In a granular filter, aerosol capture occurs due to adhesion (adherence) of vapor and liquid droplets to the grains of the material, their condensation and subsequent enlargement. It is possible in the filter to repeatedly rotate the steam stream by 90° to improve cleaning due to inertial separation of heterogeneous systems. To prevent the entrainment of the grains of the filtering material with a gas stream, the bags are covered with a mesh made of an acid-resistant material with a hole diameter of a smaller diameter than that of the grains.

Since liquid particles settle on the filter material and a layer of solid chromium oxide is also formed, this gradually leads to an increase in aerodynamic drag and a decrease in filter performance. Upon reaching a certain pressure drop across the filter (for example, 700 Pa), it must be regenerated by washing granular materials with warm (30 ... 40° C) water.

The granular filter cleaning system (5) is designed to wash grains inside the apparatus housing using nozzles through the hatches in the upper parts of the filter draining the wash water into the electrolyte tank of the installation for chromium plating of the hydraulic drive's internal surfaces with hydrostatic guides.

A radial fan (6) provides a complete exhaust gases elimination at the local exhaust system of the chromium coating complex for internal surfaces. It is assumed that the flow velocity should be limited to 1 ... 2.5 m/s, since when this value is exceeded, secondary spraying of the captured liquid from the surface layer in the form of large drops begins, and the fan operating mode is an air flow rate of 60 m³/h and the speed flow rate of 2 m/s.

4 Conclusion

A schematic diagram of the environmental protection system of the installation for chrome plating of the internal surfaces of a hydraulic drive with hydrostatic guideways is developed. To clean the exhaust air from harmful substances, such as aerosols of chromium oxides and sulfuric acid, as well as water vapor, a comprehensive gas purification system for emissions of pollutants is proposed, which consists of step-by-step cleaning in various devices, including a drip collector with two drop-off elements and a granular filter. The presented design of equipment for environmental protection of the installation for chrome-plating of the internal surfaces of a hydraulic drive with hydrostatic guideways will make it possible to effectively neutralize the air environment by purifying air from chrome anhydride vapors and other pollutants.

This work was performed with financial support of Ministry of Science and Higher Education of Russian Federation as a part of complex project for development of high-technology production «Development of high-technology production of hydraulic drives with wide range hydrostatic guideways with low movement resistance of moving elements and increased resource for test-bench equipment» according to agreement № 075-11-2019-069 dd. November, 22, 2019 between Ministry of Science and Higher Education of Russian Federation and Ltd. «Ural Engineering Center» in cooperation with General Contractor Research and Technological Department - Federal State Autonomous Educational Institution for Higher Education «South Ural State University (National Research University)».

References

1. E.M. Sycheva, A.V. Baklanova, Problems of ventilation system of galvanic production of a machine-building enterprise Sib. State Aerospace University, Krasnoyarsk, pp. 291-292 (2016).
2. S.S. Vinogradov, Ecologically safe galvanic production (Globus, Moscow, 1998).
3. S.S. Vinogradov, Organization of galvanic production. Equipment, production calculation, rationing (Globus Publ., Moscow, 2005).
4. Jean-Claude Rebuschung, E.L. Simonov, Electroplating and surface treatment, 14 (1), pp. 46-53 (2006).
5. A.O. Dahl. About drop eliminators. – <https://daly.ru/zakazchikam/o-kapleulovatelyakh>
6. D. Egger Droplet separator (patent RU2447925, 2012)
7. Hao Yi, Lehua Qi, Jun Luo, Yongan Guo, Shaolin Li, Ni Li, Materials Letters, **216**, pp. 232-235 (2018)
8. A.R. Gallyamov, M.V. Nenashev, I.D. Ibatullin, Advanced technologies, properties and application of nanostructured coatings. *Sbornik trudov Mezhdunarodnoj nauchno-tehnicheskoy konferencii im. Leonardo da Vinchi* [Proceedings of the International Scientific and Technical Conference named after Leonardo da Vinci], 1, pp. 39–48 (2013).
9. Y. Xu, Zh. Yang, J. Zhang, Chemical Engineering Science, **171**, pp. 650-661 (2017)
10. Sung Joo Hong, Byung Ryeon Kim, Chang Hyun Lee, Sung Min Woo, Chan Woo Park, International Journal of Refrigeration, **104**, pp. 213-220 (2019)
11. R. Kouhikamali, S.M.A. Noori Rahim Abadi, M. Hassani, Applied Thermal Engineering, **67**, 1–2, pp. 214-222 (2014).
12. M. Kim, G-T. Lim, Y.-J. Kim, B.Han, Ch. G. Woo, H.-J. Kim, Journal of Aerosol Science, **117**, pp. 63-73 (2018)

13. S. Ma, M. Zhang, J. Nie, J. Tan, B. Yang, S. Song, Carbohydrate Polymers, **203**, pp. 415-422 (2019)
14. S. Shiratori, Y. Inami, M. Kikuchi, Thin Solid Films, **393**, 1–2, pp. 243-248 (2001)
15. LV-Engineering, Ventilation systems and air purification of galvanic production. – <http://www.galvanicline.ru/show.php?page=355>
16. D.V. Ardashev, L.V. Shipulin, A.S. Degtyareva-Kashutina, Lecture Notes in Mechanical Engineering, in print (2020).
17. S.G. Nitskaya, K.R. Smolyakova, I.V. Shmidt, Solid State Phenomena, 299SSP (2019)