

Diesel efficiency improvement strategy

Igor Ivanov^{1,*}

¹Don State Technical University, pl. Gagarina, 1, Rostov-on-Don, 344003, Russia

Abstract. This thesis presents the author's method of analyzing the indicator diagrams of a diesel engine at idle mode, which have a two-peak nature, based on the theory of catastrophes in order to improve the operation process in this mode, and offers suggestions for improving this process.

1 Introduction

Currently used agricultural production is used not only as essential consumer market but also is widely applied for exporting the domestic products. Moreover, the efficiency of exports largely depends on the productivity of agricultural machinery. At the same time, the main energy use of various types of agricultural machinery and transport is the diesel engine.

These engines are widely used in various fields of activity: in agricultural production in transport: road, railway, river, sea and in various energy systems. Despite the different modes of operation in various fields of activity, there are general principles and patterns, but meanwhile there are general problems [1].

Leading foreign companies and domestic enterprises that manufacture diesel engines have developed design parameters that allow one to obtain very good technical and economic indicators when the engine is running at nominal mode, but the idle and low load mode is one of the unsolved problems for all types of engines, and according to the conditions operation, these modes must be performed. Currently, to solve this problem, work is being carried out in the following directions:- adjusting in the fuel supply system [2], - changing the air supply process [3,4], changing the fuel composition [5], using the exhaust gas recirculation system [6-11]

2 Urgency

Idle running is a critical function of a diesel engine [12].

At low fuel supply modes, a sharp violation of the normal operation of the fuel equipment occurs, which leads to uneven operation of the cylinders, deterioration of the mixture formation and fuel combustion process, the appearance of incomplete burning and exhaust of unburned fuel due to poor atomization.

Therefore, improving the idling operation not only reduces fuel and oil consumption, but also reduces the formation of carbon deposits and oil dilution due to getting of unburned fuel into the diesel crankcase. At the same time, carbon deposits, formed mainly at

* Corresponding author: igoriv740@yandex.ru

idle speed, do not allow the maximum power of the diesel engine to be achieved when operating at nominal mode, and a decrease in oil viscosity contributes to a sharp increase in the wear of the piston group, which reduces the duration period of the engine.

As a result, the improvement of the diesel engine operation at idle and low load modes is one of the vital problems of diesel engine construction, and research is currently being carried out on this problem in various spheres.

2 Formulation of the problem.

Diesel operating at idle mode is a critical function of the diesel. Therefore, at present, various methods are being developed to improve the operational process at this mode. The peculiarity of this mode is the two-peak combustion process, which is reflected in indicator diagrams, which are difficult to assess unambiguously.

That is why the following tasks are stated: how to analyse the process of a diesel operation at idle mode using indicator diagrams and how to increase the efficiency of its operation at this mode.

3 The theoretical part

The diesel operation is accompanied by a great complexity of physical and chemical processes: spraying, self-ignition and combustion of fuel. At the same time, the spray has three phases: initial - with a high content of large particles and large inhomogeneity of the droplet size, medium - in the form of a homogeneous finely dispersed mass and final - similar in composition to the initial one. For self-ignition and combustion processes, atomized in the middle phase is most suitable.

At heavy load, the middle phase makes up essential part of the spray, which contributes to easy self-ignition and flame distribution in the combustion chamber.

At idle mode, when a small dose of fuel is injected, the middle phase is significantly reduced and an inhomogeneous spray with a large difference in particle size occurs.

Meanwhile, in the first period of time a very small part of the fuel ignites spontaneously, and then when the more roughly atomized fuel warms up, additional self-ignition occurs. As a result, the indicator chart has a two-peak character and such a chart is difficult to analyze with existing methods. It is important that such a process is observed in both two-stroke and four-stroke diesel engines.

For a definite assessment of such diagrams, the method of catastrophes was applied with the definition of pressure change in the form of a change in the stability of a system based on an assembly catastrophe, which has 2 maximums and one minimum, or vice versa.

$$P_{(a_1, a_2)}(t_i) = t_i^4 + a_1 \cdot t_i^2 + a_2 \cdot t_i. \quad (1)$$

Critical points appear when $P'_{(a_1, a_2)}(t) = 0$,
i.e. when

$$4 \cdot t_i^3 + 2 \cdot a_1 \cdot t_i + a_2 = 0, \quad (2)$$

and they merge when $P''_{(a_1, a_2)}(t) = 0$,
i.e. when

$$12 \cdot t_i^2 + 2 \cdot a_1 = 0. \quad (3)$$

Solving equations (2) and (3) together, we exclude t . As a result, we obtain an equation that determines the multitude of catastrophes C :

$$C = 8 \cdot a_1^3 + 27 \cdot a_2^2 = 0. \quad (4)$$

When $C > 0$ function $P_{i(a_1, a_2)}(t_i)$ has one critical point (minimum); at $C < 0$, it has two minima and one maximum, or vice versa.

For analysis by formula (1), the dependence of $P_{i(a_1, a_2)}(t)$, representing a fourth-order parabola as an approximate curve for the experimental one, is selected by the coefficients a_1 and a_2 by the least squares method:

$$W_{(a_1, a_2)} = \sum [P_i - P(t_i)]^2 \quad 8,5 \text{ пт} \quad (5)$$

where $W_{(a_1, a_2)}$ – the sum of the standard deviations of the real pressure P_i from $P_i(t)$, according to equation (5).

Substituting the value of formula (1) into formula (5), we obtain:

$$W_{(a_1, a_2)} = \sum [P_i - (t_i^4 + a_1 t_i^2 + a_2 t_i)]^2. \quad (6)$$

With the minimum standard deviation, the first partial derivatives should be equal 0.

$$\begin{aligned} \frac{\partial W}{\partial a_1} &= 2 \sum [P_i - (t_i^4 + a_1 t_i^2 + a_2 t_i)] (-t_i^2) = 0; \\ \frac{\partial W}{\partial a_2} &= 2 \sum [P_i - (t_i^4 + a_1 t_i^2 + a_2 t_i)] (-t_i) = 0 \end{aligned} \quad (7)$$

From these conditions, we obtain a system of 2 equations:

$$\begin{aligned} a_1 \sum_{i=1}^n t_i^4 + a_2 \sum_{i=1}^n t_i^3 &= \sum_{i=1}^n (P_i - t_i^4) t_i^2; \\ a_1 \sum_{i=1}^n t_i^3 + a_2 \sum_{i=1}^n t_i^2 &= \sum_{i=1}^n (P_i - t_i^4) t_i. \end{aligned} \quad (8)$$

Solving the system, we obtain the values of a_1 and a_2 :

$$\begin{aligned} a_1 &= \frac{\sum_{i=1}^n (P_i - t_i^4) \cdot t_i^2 \sum_{i=1}^n t_i^2 - \sum_{i=1}^n (P_i - t_i^4) \cdot t_i \sum_{i=1}^n t_i^3}{\sum_{i=1}^n t_i^2 \cdot \sum_{i=1}^n t_i^4 - \left(\sum_{i=1}^n t_i^3 \right)^2}; \\ a_2 &= \frac{\sum_{i=1}^n (P_i - t_i^4) \cdot t_i \sum_{i=1}^n t_i^4 - \sum_{i=1}^n (P_i - t_i^4) \cdot t_i^2 \sum_{i=1}^n t_i^3}{\sum_{i=1}^n t_i^2 \cdot \sum_{i=1}^n t_i^4 - \left(\sum_{i=1}^n t_i^3 \right)^2}. \end{aligned} \quad (9)$$

For the analysis of indicator diagrams, the obtained dependences in the form of formulas cannot be achieved in practice, since the numerator and denominator contain different physical quantities and it is difficult to evaluate their ratios objectively.

Therefore, the combustion process inside the cylinder, which was recorded by the change in pressure for the time being, was presented in relative units of pressure and time. To implement this method, the relative pressure was determined by the relative pressure value to the maximum value - P_z .

The value of time was estimated by the solidity of the angle of rotation of the lower crankshaft relative to the period of active combustion from 356° to 16° of rotation of the lower crankshaft. In this case, from 4° to 12° (the period of active combustion), the intervals were taken after 1° , and the remaining intervals - after 2° .

As a result, the coefficients a_1 and a_2 , calculated on the basis of processing indicator diagrams, will look like:

$$a_1 = \frac{\sum_{i=1}^n (\bar{P}_i - \bar{t}_i^4) \cdot \bar{t}_i^2 \sum_{i=1}^n \bar{t}_i^2 - \sum_{i=1}^n (\bar{P}_i - \bar{t}_i^4) \cdot \bar{t}_i \sum_{i=1}^n \bar{t}_i^3}{\sum_{i=1}^n \bar{t}_i^2 \cdot \sum_{i=1}^n \bar{t}_i^4 - \left(\sum_{i=1}^n \bar{t}_i^3 \right)^2};$$

$$a_2 = \frac{\sum_{i=1}^n (\bar{P}_i - \bar{t}_i^4) \cdot \bar{t}_i \sum_{i=1}^n \bar{t}_i^4 - \sum_{i=1}^n (\bar{P}_i - \bar{t}_i^4) \cdot \bar{t}_i^2 \sum_{i=1}^n \bar{t}_i^3}{\sum_{i=1}^n \bar{t}_i^2 \cdot \sum_{i=1}^n \bar{t}_i^4 - \left(\sum_{i=1}^n \bar{t}_i^3 \right)^2}, \quad (10)$$

where

$$\bar{P}_i = \frac{P_i}{P_z}$$

P_i – pressure from the indicator diagram at the end of the i -th interval;

P_z – maximum pressure from the indicator diagram;

$$\bar{t}_i = \frac{\Phi_i}{20}$$

where Φ_i – the angle of rotation of the lower crankshaft from the origin (356°) to the end of the i -th interval;

20 – the angle of rotation of the lower crankshaft from the origin (356° about) to the end of the i -th interval;).

To evaluate the proposed technique, experimental data were taken from five combustion processes in the O - D100 engine of the experimental compartment of the Vsesoyuzny Scientific Research Institute of Railway Transport. During these experiments, only one structural element was changed - the nozzle of the atomizer, of which 2 versions of serial samples and 3 versions of the nozzles developed by the author.

During the tests, all parameter measurements were recorded automatically and for each diagram the average arithmetic data of 9 automatic measurements of fuel consumption were taken.

The dependence of the calculation of C and fuel consumption G is shown in Figure 1.

Table 1. The dependence of the indicator C on fuel consumption G

№	Process name	G kg/hour	C
1	With standard serial nozzle	3,379	-129,272255
2	With standard running nozzle	3,414	-119,363938
3	With single-hole cylindrical nozzle	3,690	-76,170451
4	With single hole tapered nozzle	3,439	-103,592987
5	With three holes parallel to the shaft axis	3,254	-152,722012

The results of mathematical processing on a computer using the Mathcad system are presented in table.1, and the resulting linear regression in Fig. 1.

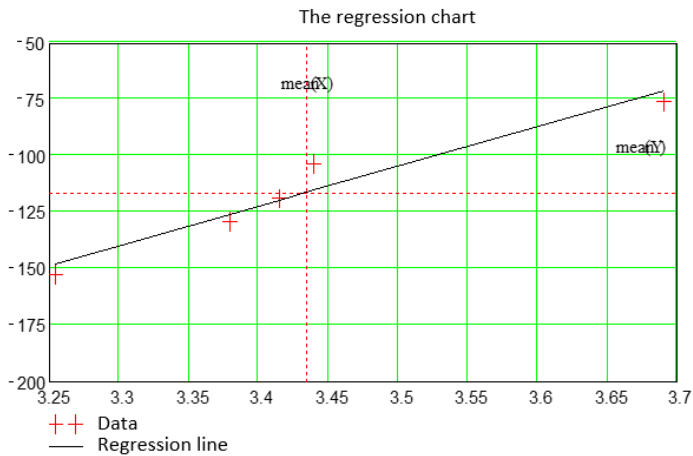

Fig. 1. Graphic dependence $C=f(G)$

Table 2. Linear regression

	0	1
0	3,254	-152,722012
1	3,379	-129,272255
2	3,414	-119,363938
3	3,439	-103,592987
4	3,690	-76,170451

Number of data points: $n=5$

Comparative analysis of the C index and fuel consumption for different types of atomizers made it possible to determine the dependence of these indicators in the form of linear regression. This makes it possible to improve the engine operation process at low cost at idle speed and low loads.

4 Practical suggestions

1 In order to improve the atomization and ignition of fuel, its equal supply through the cylinders at low loads and idle mode, the assignment was to increase the fuel supply without changing the pump adjustment.

To solve this problem, the TSIP system (the theory of solving inventive problems) [13, 14] was applied, on the basis of which a new technical solution was developed, patented in the form of a "Method of diesel operation at low supply and idle speed and a device for its implementation" [15].

The problem is solved by the fact that in this mode, the fuel supply is increased due to the hydraulic tightening in the nozzle by the formation of a hydro-locking channel by reducing the diameter in the middle part of the precision needle surface, and for an engine with diverging pistons, in addition, fuel is supplied in the form of parallel sprays in the direction of the upper piston.

The technical result of the proposed technical solution is to increase the efficiency, increase the duration of the transport diesel engine and reduce harmful emissions during its operation.

The scheme of a nozzle with a hydraulic tightening is shown in Fig. 2.

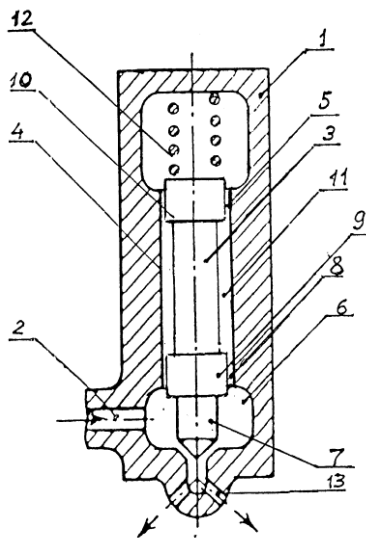

Fig. 2. Hydraulically tightened nozzles Diesel nozzle with hydraulic tightening -5 contains: 1 - case; 2 - fuel supply channel; 3 - locking needle; 4 - the inner surface of the case; 5 - gap between the outer surface of the needle and the inner surface of the case; 6 - sub-needle cavity; 7 - the lower part of the locking needle; 8 - throttling channel; 9 - a tightening lower belt; 10 - tightening upper belt; 11 - hydro-locking channel; 12 - spring; 13 - holes for fuel injection.

This injector operates as follows: fuel from a high pressure pump (not shown in the figure) enters the under needle cavity 6 through the fuel channel 2. In the under needle area 6, the pressure rises. In this case, part of the fuel through the throttling channel 8 penetrates into the hydraulic locking channel 11, which is formed by reducing the diameter in the middle part of the precision surface of the needle and is located between the tightening belts 9 and 10 and at the same time does not have time to get through the throttling channel 5 at idle speed. As a result, when the engine is running, there is fuel in channel 11 constantly, which is a hydro seal. The pressure in the sub-needle area 6 rises until the pressure force of the initial tightening of the spring 12, acting on the shut-off needle 3, is exceeded, and the needle rises and through the holes 13 fuel is injected into the combustion chamber. After that, due to the drop in pressure in the under-needle cavity 6 and the action of the spring 12, the shut-off needle 3 is lowered and seals the fuel passage to the holes 13.

Meanwhile, due to the hydraulic tightening in the nozzle (5), the fuel supply increases with a constant supply of the high-pressure fuel pump, which improves the process of self-ignition and combustion and contributes to an increase in efficiency and a decrease in harmful emissions during its operation at low loads and idle mode.

2. For an engine with divergent pistons in this mode, fuel is supplied in the form of parallel streams directed towards the upper piston. (Fig. 3.)

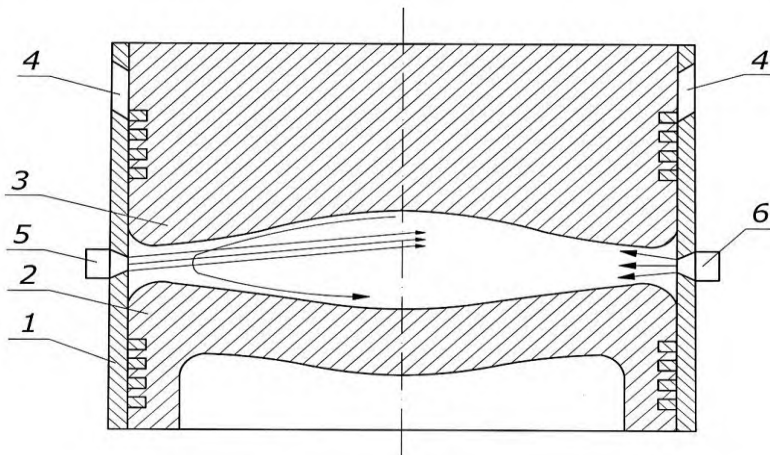

Fig. 3. Scheme of diagram of the basic design of the combustion chamber of an engine with diverging pistons

The combustion chamber contains: 1-cylinder liner, inside which there are 2-lower and 3-upper pistons; 4-scavenging ports for air supply; 5-injector with hydraulic tightening and parallel fuel injection; 6 - standard nozzle.

Diesel operates as follows: air from the atmosphere is sucked into a compressor (not shown in the drawing), where it is compressed and supplied through the scavenging ports (4) to the combustion chamber, where fuel is supplied through a nozzle (5) with a hydraulic tightening (nozzle (6) in modes of low supply and idle speed does not work). As a result, a high concentration of fuel with a finely dispersed atomization and a long time of the fuel burning are provided due to the creation of a vacuum on the inner surface of several parallel sprays moving with closely located axes.

As a result, the fuel consumption in this mode is reduced while the parameters of the nominal mode remain unchanged, which ensures an increase in the operational efficiency of the engine.

5 Conclusion

1. To improve the idle run of a diesel engine, a method for evaluating the efficiency by using a catastrophe model is proposed, which makes it possible to make further improvements to the design with an assessment of efficiency by analyzing indicator diagrams. This method can also be used for any system that has a non-linear measurement of process parameters.
2. To improve the efficiency of the diesel engine at idle mode and low loads, a method to increase the fuel supply due to the hydraulic tightening in the nozzle is proposed, which makes it possible to increase the efficiency, to enhance the duration of a transport diesel engine and to reduce harmful emissions during its operation.
3. For an engine with diverging pistons at this mode, a method for supplying fuel in the form of parallel sprays directed towards the upper piston is proposed, which ensures a high concentration of fuel with a fine atomization and a long time of the fuel burning, due to the creation of a vacuum on the inner surface of several parallel sprays moving with closely located axes.

References

1. V. Kvashin, V. Sherbakova, S. Zakharov. Bulletin of the Omsk State Agrarian University **2(30)**, 109-115 (2018)
2. I. Ivanov, *Improving the efficiency of transport power plants*. Monography 81-95 (2010)
3. V. Vedruchenko, V. Krainov, E. Lazarev, P. Litvinov, Omsk Scientific Bulletin. Ser. Devices, machines and technologies **6(150)**, 68-72 (2016)
4. E. Lazarev, A. Pomaz, A. Salov, *Bulletin of the South Ural State University. Series Machine Engineering* 132-136 (2013)
5. A. Ukhanov, D. Ukhanov, I. Adgamov, Journal: Niva of the Volga region. Publisher: Penza State Agrarian University (Penza) **1(34)**, 66-71 (2015)
6. United States Patent no. 10,634,101, issued on April 28, was assigned to MAGNETI MARELLI S.p.A. (Corbetta, Italy). "Exhaust gas recirculation valve actuator device (EGR) in an internal combustion engine and related exhaust gas recirculation valve assembly" was invented by Giancarlo Bartolotta (Corbetta, Italy), Stefano Domma (Corbetta, Italy), Matteo Avanzi (Corbetta, Italy) and Stefano Musolesi (Corbetta, Italy). The patent was filed on June 26, 2017, under Application No. 15/632,975. *For further information, including images, charts and tables, please visit: <http://patft.uspto.gov/netacgi/nph-Parser?Sect1=PTO2&Sect2=HITOFF&p=1&u=%2Fnetahhtml%2FPTO%2Fsearch-bool.html&r=1&f=G&l=50&co1=AND&d=PTXT&s1=10634101&OS=10634101&RS=10634101> (Last accessed 13.06.2020)
7. United States Patent no. 10,480,432, issued on Nov. 19, was assigned to CONTINENTAL AUTOMOTIVE GMBH (Hannover, Germany). "Exhaust gas recirculation valves for a forced-induction internal combustion engine with exhaust gas recirculation" was invented by Hong Zhang (Tegernheim, Germany). The patent was filed on Aug. 10, 2015, under Application No. 15/507,451. *For further information, including images, charts and tables, please visit: <http://patft.uspto.gov/netacgi/nph-Parser?Sect1=PTO2&Sect2=HITOFF&p=1&u=%2Fnetahhtml%2FPTO%2Fsearch-bool.html&r=1&f=G&l=50&co1=AND&d=PTXT&s1=10480432&OS=10480432&RS=10480432> (Last accessed 23.06.2020)

8. United States Patent no. 10,288,014, issued on May 14, was assigned to Ford Global Technologies LLC (Dearborn, Mich.). "Internal combustion engine with exhaust-gas recirculation arrangement and method for operating an internal combustion engine of said type" was invented by Ford Global Technologies, LLC (Dearborn, Mich.). The patent was filed on Sept. 29, 2017, under Application No. 15/721,587. *For further information, including images, charts and tables, please visit: <http://patft.uspto.gov/netacgi/nph-Parser?Sect1=PTO2&Sect2=HITOFF&p=1&u=%2Fnetahtml%2FPTO%2Fsearch-bool.html&r=1&f=G&l=50&co1=AND&d=PTXT&s1=10288014&OS=10288014&RS=10288014> (Last accessed 23.06.2020)
9. United States Patent no. 10,215,086, issued on Feb. 26, was assigned to FEV Europe GmbH (Aachen, Germany). "Exhaust gas recirculation system for an internal combustion engine and method for operating such an exhaust gas recirculation system" was invented by FEV GMBH (Aachen, Germany). The patent was filed on June 16, 2015, under Application No. 15/325,578. *For further information, including images, charts and tables, please visit: <http://patft.uspto.gov/netacgi/nph-Parser?Sect1=PTO2&Sect2=HITOFF&p=1&u=%2Fnetahtml%2FPTO%2Fsearch-bool.html&r=1&f=G&l=50&co1=AND&d=PTXT&s1=10215086&OS=10215086&RS=10215086> (Last accessed 23.06.2020)
10. United States Patent no. 9,574,526, issued on Feb. 21, was assigned to NISSAN MOTOR Co. LTD. (Yokohama-shi, Japan). "Exhaust gas recirculation control device and exhaust gas recirculation control method for internal combustion engine" was invented by NISSAN MOTOR CO., LTD. (Yokohama-shi, Kanagawa, Japan). The patent was filed on Dec. 24, 2013, under Application No. 14/763,933. *For further information, including images, charts and tables, please visit: <http://patft.uspto.gov/netacgi/nph-Parser> (Last accessed 11.07.2020)
11. United States Patent no. 8,555,864, issued on Oct. 15, was assigned to Volkswagen AG (Wolfsburg, Germany). "Internal combustion engine with an exhaust-gas recirculation and method for operating an internal combustion engine" was invented by Hans-Georg Nitzke (Wettmershagen, Germany), Jorg Larink (Haren/Ems, Germany), The patent was filed on Nov. 21, 2011, under Application No. 13/300,905. *For further information, including images, charts and tables, please visit: <http://patft.uspto.gov/netacgi/nph-Parser?> (Last accessed 11.07.2020)
12. I. Ivanov, G. Persiyanova, *Materials of the 7th International Scientific and Practical Conference, as part of the 17th International Agroindustrial Exhibition "Interagromash-2014"* 396-397 (2014)
13. M. Meerovich, L. Shragina, *Technology of creative thinking* 298-316 (2016)
14. I. Ivanov, G. Persiyanova, *Collection of articles of the 8th international scientific - practical conference "Interagromash -2015"* 592-596 (2015)
15. I. Ivanov, Patent Russian Federation №2734087 (2020)