

# Organization of data transmission in the developed communication system for implementation in the agro-industrial complex

*Dmitry Cheremukhin*<sup>1,\*</sup>

Far Eastern Federal University, Russia, Vladivostok

**Abstract.** This article is devoted to the discussion of the initial results of a research project devoted to the development of a magneto induction communication system, as well as the study of the main goal of the research at the moment: the search for profitable ways to build and transmit data. Based on the above goal, the physical meaning of the proposed method based on the electrohydraulic Yutkin effect was considered, which can be used to retransmit a signal under water between a network of antennas to increase the range of transmitted information. The creation of an experimental network of receiving and transmitting devices with a set of antennas will be the first step towards further research in the field of promising underwater wireless communications for use in the agro-industrial complex (AGP). The information presented in the text is recommended to a narrow circle of specialists, primarily in the field of information transmission, development of modern means of communication.

## 1 Introduction

Now, digital technologies cover most areas. Magnetic induction (MI) communication is a promising method of land and underwater transmission of useful information that can be widely used in agro-industrial areas, such as: fish farming (aquaculture), agriculture. In these areas, "smart" digital systems have recently been developed that will modernize the processes of collecting, processing, transmitting, and monitoring information. When implementing the development in fish farming, it is planned to check the condition of swimming pools, the environment (the content of dangerous substances in the air or water that exceed the norm). Agriculture will be able to collect information about weather conditions, the state of crops, precipitation, as well as about approaching dangerous and destructive phenomena (elements). Pro MI has the following advantages: a slight delay in signal propagation (the speed of propagation of the MI wave under water: 33300000 meters per second), the absence of multipath signal, as well as quiet and invisible properties of underwater operations.

This will enable real-time transmission of information between multiple underwater sensors, voice and text communication between shallow-water divers, monitoring of underwater equipment from surface vessels, telemetry of underwater objects, control of

---

\* Corresponding author: [dodgevipersrt15@mail.ru](mailto:dodgevipersrt15@mail.ru)

underwater equipment from surface ships, and environmental expeditions and search missions.

Future local networks of MI transmitters with antennas can be used in areas from the oil industry to aquaculture: pollution monitoring, climate accounting, forecasting of natural disasters (tsunamis, floods, etc.), search missions, and marine environment research. From my point of view, the development of innovative underwater wireless ocean surveillance systems is a major step towards a more complete understanding and maintenance of life on Earth [1-2].

Underwater communication based on MI differs from acoustic or optical waves in that it is implemented using a magnetic field that changes over time and allows information to be exchanged between the transmitting and receiving sides.

## 2 Materials and methods of the experiment

In MI-communication channels, information is transmitted and received using a pair of antennas (information is transferred by a time-varying magnetic field). This magnetic field is generated by a modulated sinusoidal current in the MI-antenna coil on the transmitter. The receiver receives information using a demodulated induced current in a spiral antenna, as shown in Figure 1. It is worth paying attention to the main feature of this communication, which is that in MI channels the transmission distance is less than the wavelength.

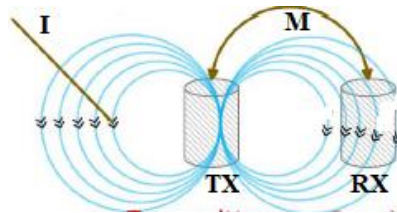

**Fig. 1.** MI data transmission system.

Earlier, in the process of completing the final work at the University, a magneto induction transmitting device with an antenna was developed, shown in Fig. 2.

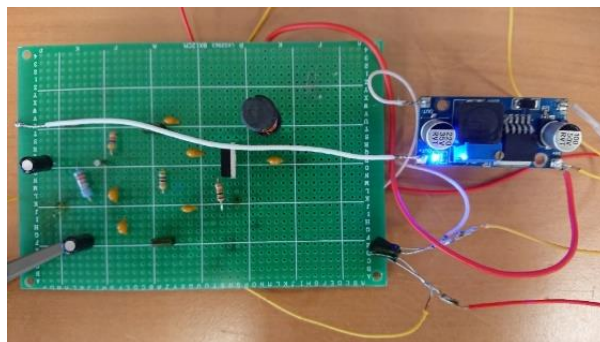

**Fig. 2.** General view of the transmitter Board with a DC Converter.

When checking the performance, a digital signal was sent to the low-frequency input of the transmitter Board, and it was set to the required voltage level. In order to lower the power supply voltage of the Board from +12 to +6 V, a DC-DC Converter was used, which was connected to the power source. After connecting the receiving antenna to the oscilloscope, and placing the antennas parallel at a distance, a signal was received from the transmitting antenna (shown in Fig. 3).

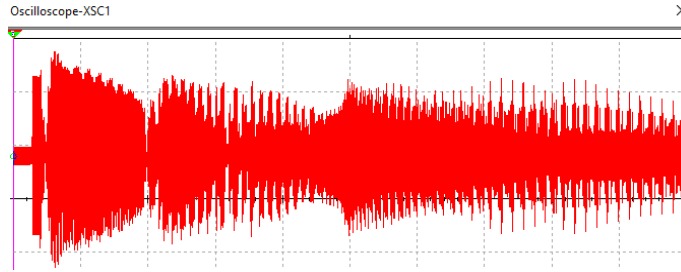

**Fig. 3.** Taken with the transmitter signal.

Having all the necessary software tools and electronic tools, the communication channel was simulated using the manufactured magnetic antennas shown in (Fig. 4).

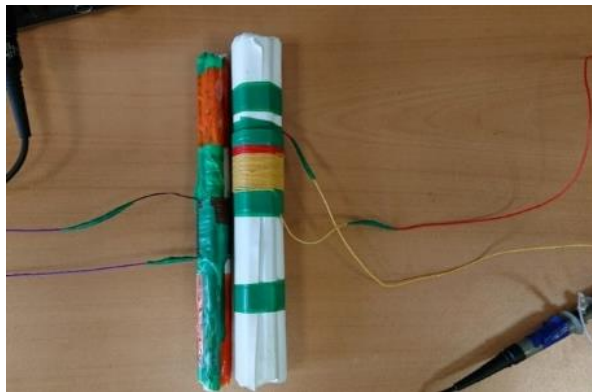

**Fig. 4.** Receiving and transmitting magnetic antennas.

For their production, it took: ferrite rods: 7 pieces (1 cm in diameter, 30 cm long); single - core wire-for winding the resonant coil (30 turns) and the communication coil for communication with the antenna wire (1.5-2 turns); a capacitor with a capacity of 3.9 nF.

Throughout the project, an important aspect is to evaluate the directional properties of these antennas. It is known that the magnitude of the electromotive force induced in the antenna by a magnetic field depends on its position in space and the maximum when the plane of the turns is directed towards the radio station. If the frame is rotated around a vertical axis, then in one full revolution the amplitude of the electromotive force induced in it will reach the highest value twice and decrease twice to almost zero. The directional pattern (DN) shown in (Fig. 5) will be a "figure eight".

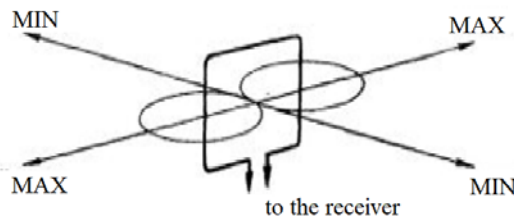

**Fig. 5.** Diagram directivity of the magnetic antenna.

By placing a core (ferrite) inside the antenna, the electromotive force that occurs in it under the influence of a magnetic field increases sharply (since it concentrates the field lines of force), so that the body is permeated by a magnetic flux of greater density [3]. The value that shows how many times the magnetic field in the core exceeds the value of the external

field is called the magnetic permeability of the core. It is higher, therefore, the receiving properties of the magnetic antenna are better.

As described earlier, the MI signal under water does not extend far (only within 10-15 meters). To increase the transmission distance over long distances and increase the bandwidth (without increasing the transmission power or receiver sensitivity), it is proposed to build a relay system from antennas. This method of communication is the transmission of data to the destination through one or more intermediate nodes (in our case, antennas) located between the source and the destination.

Retransmission can provide extended coverage and therefore higher reliability and throughput at lower cost and less complexity than traditional peer-to-peer communication systems.

The basis for creating such a network can be the electrohydraulic effect (EHE), which was developed by the Russian scientist Lev Yutkin, and is the formation of a hydraulic shock wave with a high efficiency when an electric current passes through a liquid.

In their scientific articles, many scientists (Mayer V. V., Meriin B. V., Blazin B. S., Kurets V. I., Eremin V. Ya., and others) described the opportunities that were achieved thanks to EHE, namely: building new technologies and principles of processing in the oil industry, crushing aluminum and polymer fractions from pharmaceutical waste blisters, disinfection of treated effluents, cleaning of wool and food; production and enrichment of peat; cleaning of livestock waste; cable laying, land reclamation, and soil treatment with the Yutkin effect allow you to grow crops without fertilizing the soil, and so on [4].

Some works, for example, are devoted to the development of a number of new devices based on the Yutkin effect. For example, a high-pressure fuel pump (electrohydraulic pump) based on the Yutkin effect can operate without an Electromechanical drive, which eliminates the energy consumption associated with a high-pressure fuel pump and reduces the noise produced by the internal combustion engine. It also allows you to create a higher overpressure than in serial high-pressure fuel pumps. This leads to an improved fuel supply to the combustion chambers and an increase in the performance of the internal combustion engine [5].

Returning to our own research, we suggest making a laboratory setup for reproducing and testing the Yutkin effect, shown in (Fig. 6) [6].

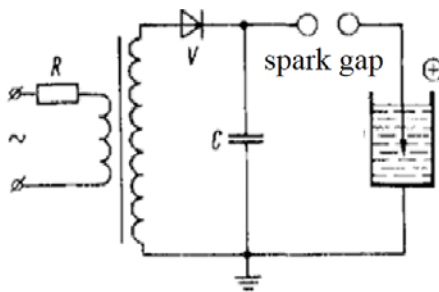

**Fig. 6.** Electrical diagram for testing the Yutkin effect.

The circuit consists of a charging resistance, a transformer, a rectifier, a gap forming a spark discharge, and a capacitance (capacitor) [6].

The principle of operation of the unit is based on the interaction of high-voltage electrical pulses with a liquid. First, the transformer generates a low voltage of 24 V and transmits it to the transformer coils, which in turn increase this voltage. The high voltage is then transmitted to a diode rectifier designed to "cut off" the negative half-cycles of the signal. After that, the signal is sent to the capacitor. To regulate both the required voltage values and the capacitance accumulated by the capacitor, a forming spark gap was introduced into the circuit, acting as a simple spark gap. It transfers the charge from the capacitor to one of the

electrodes through the air, and the rest of the charge from the capacitor goes directly to the other electrode. After that, a high-voltage breakdown occurs between the electrodes placed in the water, which causes the occurrence of an electro-hydraulic shock, which manifests itself as a loud pop with a local increase in pressure of several tens of thousands of atmospheres. After the excess pressure ceases, condensation (relaxation) of previously formed liquid vapors occurs.

In order to apply this effect to retransmission of signals under water, it is proposed to place a spark gap that creates pressure pulses in water in the focus of the parabola to form a flat front of directed acoustic radiation. Since the spark gap creates only short pulses, information transmission is formed by modulating these pulses in amplitude and time position. It is necessary to check the dependence of the power and voltage on the spark gap to form a pressure of 1 Pa at a distance of 1 m from the antenna, as well as the duration of the generated pulse at this distance.

### 3 Results and discussion

It was found that magnetic antennas should preferably operate at low frequencies in seawater due to attenuation and induced eddy currents that create a secondary field in the conducting medium.

The most important limiting factor of such systems is distance (since the transmission of various types of information through wired media, such as sea water, is only possible over short distances). The magnetic field loses its intensity with the distance traveled in the medium, and as it goes deeper into the water, according to the expression [7]:

$$\delta = \sqrt{\frac{2}{\omega \cdot \mu \cdot \sigma}} \quad (1)$$

Based on the tests, it was found that: the values of losses on the route of the MI system are higher than in fresh water due to the higher value of the conductivity of sea water; when organizing a communication channel in sea water, the penetration depth (with increasing frequency) of the signal is lower than in fresh water; the received signal power, which depends on the distance of the transmitter and receiver (in our case, 10 m), will be equal to 12 dB.

Figure 7 shows the experimentally determined dependence of the signal penetration depth on the frequency (sea water is blue ( $\sigma=4$  S/m) and fresh water is orange ( $\sigma=0.01$  S/m)).

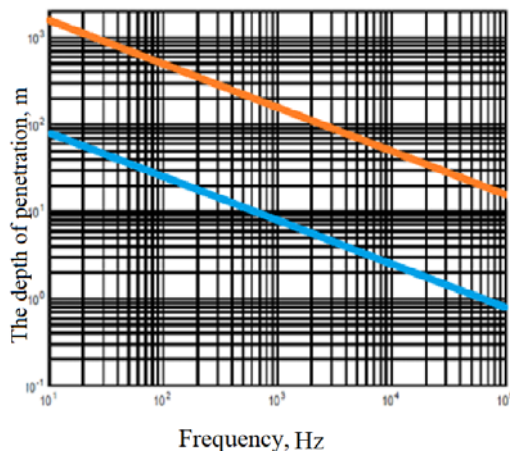

**Fig. 7.** The depth of penetration for marine and fresh water.

The following relationship, shown in Figure 8, shows the received signal strength, which depends on the distance of the transmitter and receiver.

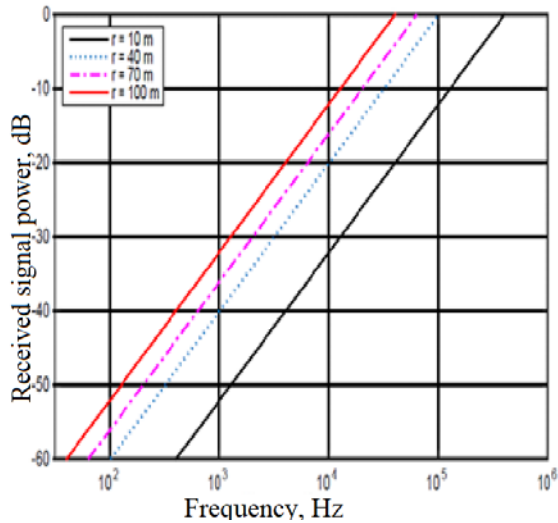

**Fig. 8.** Received signal power as a function of distance.

Assuming a bandwidth of 20000 Hz, the capacity (data transfer rate) for our communication system was calculated, which was about 30 kbit / s.

Based on the idea of an electro-hydraulic effect for the development of a communication network of antennas, upgraded Yutkin circuits were designed in the Multisim software package, which are currently undergoing tests and tests. The collected diagrams are shown in (Fig. 9).

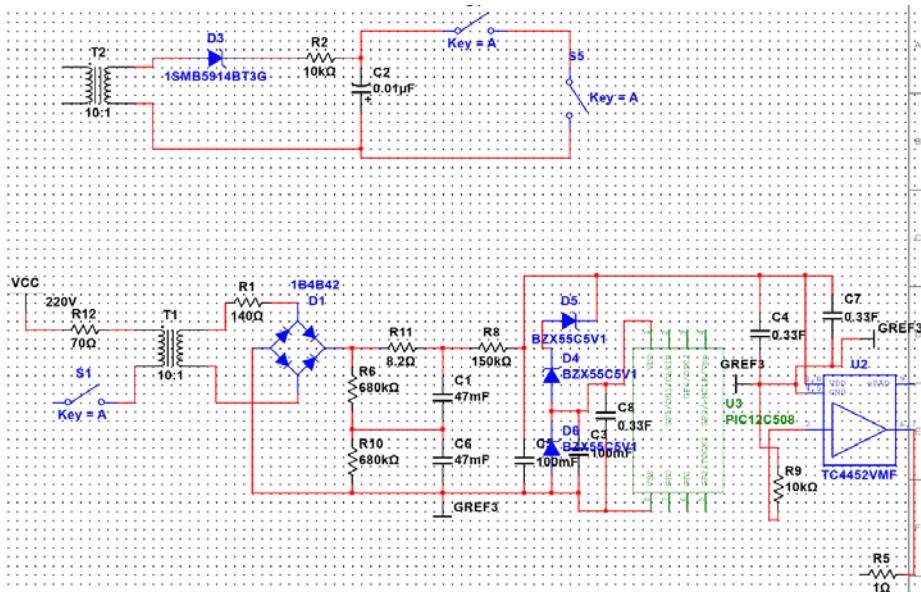

**Fig. 9.** Multisim program Window. Designed circuits for checking the electrohydraulic effect.

## 4 Conclusions

Magnetic-inductive communication is a promising method of ground and underwater data transmission that requires further development. The results obtained can be used in the further development of a relay network of antennas and their design for use in the agricultural industry. By implementing digital technologies, producers and farmers can control the full cycle of crop or livestock production, since "smart" devices measure and transmit parameters of soil, plants, microclimate, and so on. All this data from sensors, drones and other equipment is analyzed by special programs. Mobile or online applications can also be useful for determining, for example, a favorable time for planting or harvesting, calculating fertilizer schemes, forecasting crops, and much more [8].

In the future, it is necessary to work out the tasks of further searching for ways to reduce losses during signal transmission in water (both fresh and sea), determining the optimal range and speed of data transmission (search for solutions aimed at improving these parameters).

Need to pay special attention to the effect Yutkin, it is obvious that electro-devices based on Yutkin effect has found wide and useful application in various industrial sectors: construction, agriculture, oil industry, and as expected, the underwater wireless communication, using this effect will receive a new round of development. The final goal of the project will be to test the communication system in different conditions.

## References

1. I. Akyildiz, *Realizing underwater communication through magnetic induction* IEEE (Communications Magazine, 2015)
2. C. Domingo, *Magnetic Induction for Underwater Wireless Communication Networks* (IEEE transactions on antennas and propagation, 2012)
3. L.A. Aksenovich, *Physics. The energy of the magnetic field of the coil with current* (Minsk, 2017)
4. A. Kulkarni, *Optical filter enabled continuous disinfection of hospital rooms using multi-sensor feedback aided light source* (Procedia Computer Science, 2018)
5. Y.V. Maksimov, V.K. Sokovikov, A.A. Bekaev, P.I. Stokov, *New generation fuel pump* (Izvestia MGTU MAMI, 2012)
6. L.A. Yutkin, *Electrohydraulic effect and its application in industry* (Leningrad, Mechanical Engineering, 1986)
7. H. Guo, Z. Sun, *Multiple Frequency Band Channel Modeling and Analysis for Magnetic Induction Communication in Practical Underwater Environments* (IEEE Transactions on Vehicular Technology, 2017)
8. V. Borodin, *Fish Industry*, **4**, 20 (2011)