

A variant of the Fluidyne: the liquid piston ERICSSON engine

Ryma Chouder^{1,2}, Pascal Stouffs^{1,*}, Azzedine Benabdesselam²

¹Universite de Pau et des Pays de l'Adour, E2S UPPA, LaTEP, 64000 Pau, France

²Univ of science & technology Houari Boumediene (USTHB), Laboratory of Polyphasic Transport and Porous Environments (LTPMP), Algiers, Algeria

Abstract. A special configuration of Stirling liquid piston engine, known as Fluidyne, was invented fifty years ago and many works have been devoted to it since then. A variant of the Fluidyne is presented, in which the two ends of the U-tube containing the liquid piston are closed by valves, so that the system obtained belongs to the family of Ericsson engines rather than to the family of Stirling engines. This type of low-tech system is considered to be suitable for the production of low-power mechanical energy (up to ... 1... kW), for example for pumping or to drive an electric generator from renewable primary energy conversion (solar, biomass, hot gaseous effluents, ...). In the system considered, the working fluid of the Ericsson engine is air in open cycle. Different configurations are proposed for the extraction of mechanical energy. The preliminary design of a first demonstrator is presented. Results of a dynamic “intracycle” model of this liquid piston Ericsson engine are presented in the case of the coupling with a linear generator. The model allows to determine the frequency of operation of the engine, the instantaneous liquid piston position and the instantaneous working gas properties, so that the global performance of the engine can be predicted.

1 Introduction

In recent years, energy production and consumption have been increasing daily worldwide [1]. Many researches are devoted to find new technologies that use renewable energy as an energy source. Engines with external heat input such as Stirling or Ericsson [2] are proving to be a relevant technological solution for the valorization of thermal energy such as solar energy or biomass combustion to produce low power mechanical or electrical energy.

Amongst these systems, the Fluidyne, which is a liquid piston Stirling engine invented in 1969, is interesting, because it is simple, reliable, and inexpensive. However, it suffers from its bad efficiency.

Therefore, a variant of the Fluidyne is presented, in which the two ends of the U-tube containing the liquid piston are closed by valves, so that the system obtained belongs to the family of Ericsson engines rather than to the family of Stirling engines.

* Corresponding author: pascal.stouffs@univ-pau.fr

2 The Fluidyne

The first liquid piston Stirling engine was invented by C. D. West at the Harwell Laboratory in the UK in 1969, and the first machines known as Fluidyne were developed in 1970 [3]. These engines fall into the category of free piston Stirling engines (FPSE). Since the invention of the Fluidyne engine (Fig. 1), different models of liquid piston Stirling machines have been developed for a wide variety of applications. As water is generally used for the liquid piston, most liquid piston Stirling engines have been built for water pumping applications. There are three categories of liquid piston Stirling engines, which are the Fluidyne engine, the two-phase thermo-fluidic liquid piston engine and the hybrid solid-liquid piston Stirling engine.

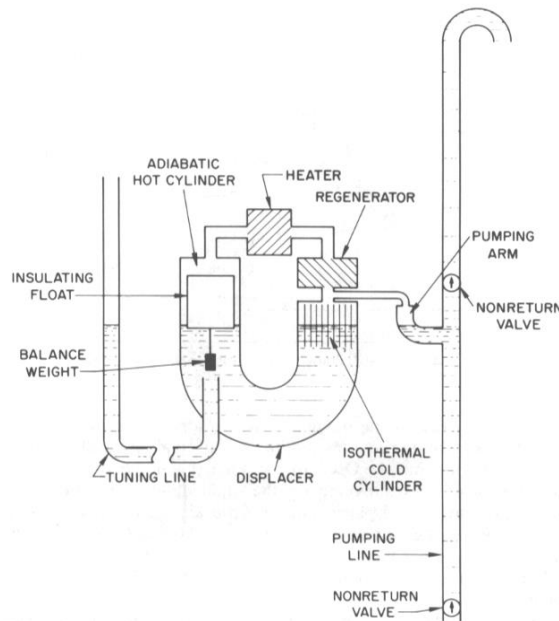

Fig. 1. The Fluidyne engine [4].

So far, several studies have been done on the development of this Fluidyne machine in order to improve its performance. At the beginning, liquid piston Stirling engines were studied theoretically by West [3–6], Elrod [7], Geissow [8] and Stammers [9] who explained the principles of operation and dynamics of these machines. West [4] reported on the history, scope and state-of-the art of the Fluidyne engine design. Among the earliest experimental studies of a Stirling pump was one built by West in 1971 [3]. This pump was able to deliver a maximum flow rate of 0.37 m³/h at an output power of 1.6 W and a maximum efficiency of 0.35%. Since then, several similar Fluidyne-based prototypes have been designed and tested [10–12], as well as Fluidynes that are powered by solar energy [13–15]. Recently, Goudarzi & al [16] built and tested for the first time a two-phase Fluidyne-based piston Stirling engine. The engine works by phase change (liquid-vapour) with a small temperature difference to produce electricity by exciting a permanent magnet. They tested three working fluids: acetone, chloroform and methane, with acetone showing the best performance due to its lower boiling temperature and low enthalpy of evaporation. They showed that the engine generates a maximum output power of 0.08 mW and a frequency of 2.9 Hz at a median fill rate of 18%. The thermal efficiency of the system is 0.3% for a temperature difference between the hot and cold source of 36°C.

Two-phase thermofluidic oscillators are classified as liquid piston Stirling engines because their configuration and critical operating characteristics are very similar to those of liquid piston Stirling engines, even though their thermodynamic cycle is not based on the Stirling cycle [17]. In 2004, Smith & al [18] proposed a two-phase non-inertial feedback thermofluidic engine that is similar to a wet Fluidyne engine. Many researchers have subsequently theoretically and experimentally studied the dynamics [19-20] and heat transfer of this engine [21-22]. The phase change characteristics allow the system to have the potential for higher power densities.

Some Stirling engines use both liquid and solid pistons. The first solid-liquid hybrid piston Stirling engine was developed by Orda [23] to improve the stability of Fluidyne operation by using a spring-loaded piston-actuator. Its thermal efficiency varies between 0.2 and 0.5%. Since then, many studies have been carried out to develop these hybrid piston Stirling machines [24-25] and some of which are powered by solar energy [23-25].

Liquid piston Stirling engines are based on a simple to build technology, with low cost materials. They are used for pumping applications or sometimes for generating electricity from industrial waste heat, solar energy or biomass. The advantages of these engines are the simplicity, reliability, low cost and ability to operate with a low temperature difference and a low frequency. But their major disadvantage is their low power, but especially their very low efficiency, i.e. less than 5% [17], as shown in Fig. 2, where the liquid piston Stirling engines are denoted by an asterisk.

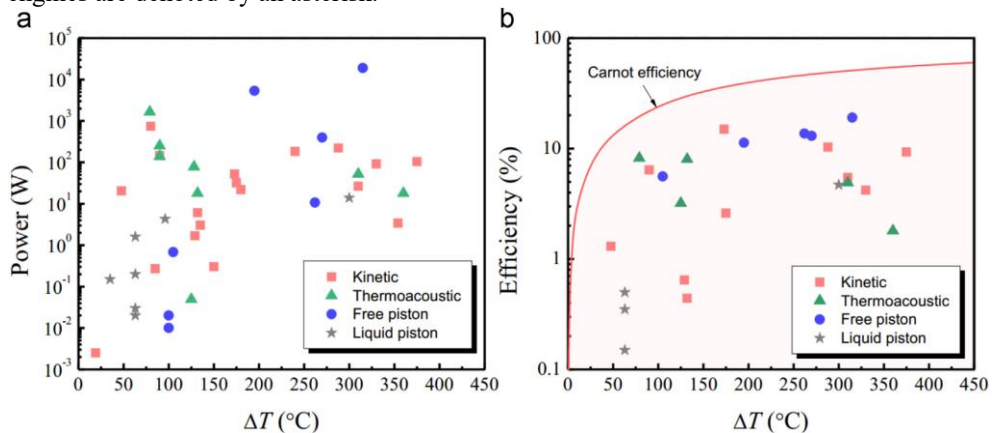

Fig. 2. Experimental results of (a) power and (b) thermal efficiency of Stirling cycle engines [17].

3 The liquid piston Ericsson engine

The family of “Hot Air Engines” comprises the Stirling sub-family, where all the working spaces are always in communication with each other, and the Ericsson family, where the compression and expansion cylinders may be isolated from the rest of the working spaces by valves [2]. The Ericsson configuration is a bit more complex technologically, due to the valves, but on the other hand, it presents some significant advantages. Among them, the fact that the exchanger volumes no longer have to be considered as dead volumes, so that the designer of an Ericsson engine does not have to face the difficult trade-off between minimising exchanger volumes and maximising exchanger surface areas as is the case with Stirling engines. Also, the performance of the Ericsson does not depend on the relative piston or piston/displacer motions and their phasing, so that simple mechanism can be used for the kinematic Ericsson engine, and the so called ‘tuning line’ (Fig. 1) is not needed for the case of liquid piston Ericsson engine. Therefore, it was considered appropriate to study a liquid piston Ericsson engine configuration.

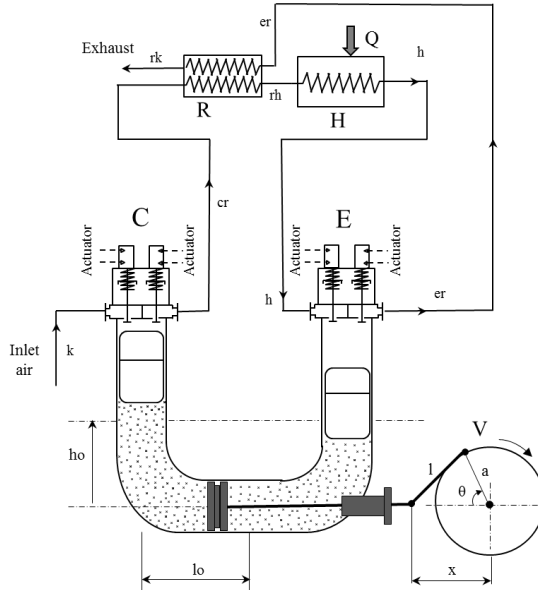

Fig. 4. The single U-tube liquid piston Ericsson engine configuration proposed by Chouder [28].

3.3 The single U-tube free liquid piston Ericsson engine

Modelling studies [29] have shown that by choosing appropriate design parameters, the kinematic mechanism can be eliminated, so that the engine comprises only one free liquid piston, whose instantaneous position is no longer dependent on a mechanical system, but only on the balance of forces applied to it. Different solutions can then be used to extract useful energy from this engine.

3.3.1 Pneumatic energy extraction

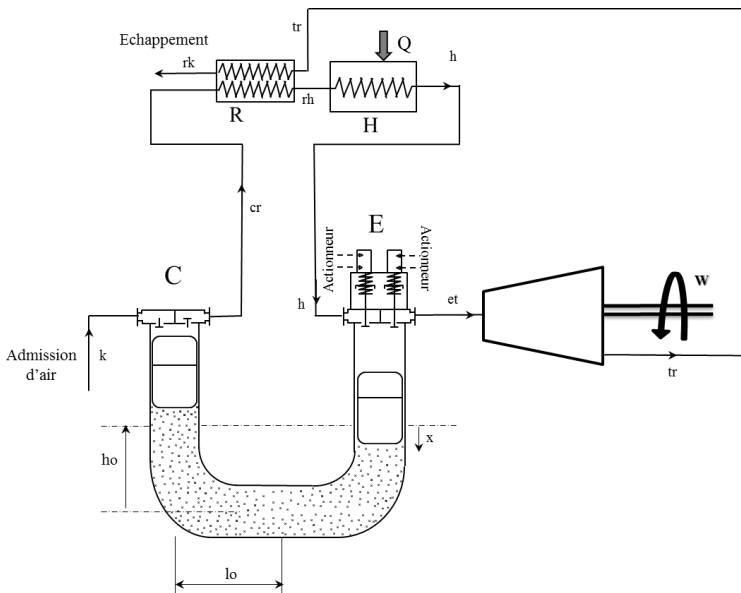

Fig. 5. The single U-tube liquid piston Ericsson engine with pneumatic energy extraction.

The useful mechanical energy can be extracted from the working fluid at the exhaust of the expansion cylinder. The working fluid, whose pressure has not been reduced to atmospheric pressure, completes its expansion in an external expansion machine, e.g. a micro-turbine (Fig. 5). In this sense, the Ericsson free liquid piston engine is similar to the gas generator of the free piston internal combustion engine originally invented by Pescara [30].

However, unlike the Pescara engine, the Ericsson free liquid piston engine allows an alternative pneumatic energy extraction configuration where the mass flow rate of the compressed fluid is divided into two parts, one of them going on through the Ericsson cycle, the other one being the useful energy extraction, for driving a micro-turbine for instance (Fig. 6).

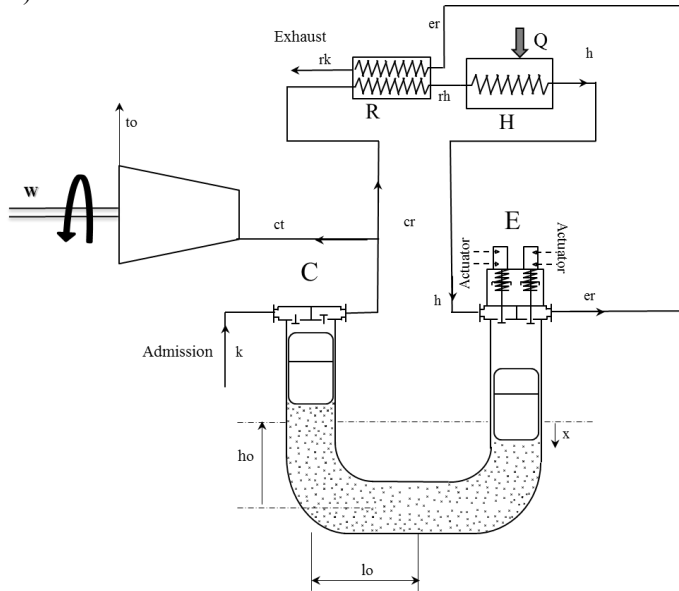

Fig. 6. Alternative pneumatic energy extraction for the single U-tube liquid piston Ericsson engine.

3.3.2 Hydraulic energy extraction

Figure 7 presents a configuration of a single U-tube free liquid piston Ericsson engine with hydraulic energy extraction. This configuration is the one that most closely resembles the original Fluidyne system. The useful energy can be used either for pumping application, or for providing mechanical energy or electricity if the pumped water drives a hydraulic micro-turbine. In this configuration, the valves in the pumped fluid line can be usual automatic check valves, or actuated valves.

Of course, the connecting line between the U-tube of the liquid piston and the pumping line can be equipped with a diaphragm, in order to avoid mixing between the liquid piston fluid and the pumped fluid. It is also possible to equipped the line with a free pumping piston one face of which being driven by the water in the U-tube, the other face driving the pumped fluid (Fig. 8). By having different piston surfaces on both sides, it is possible to decouple the pumping pressure from the pressure in the U-Tube.

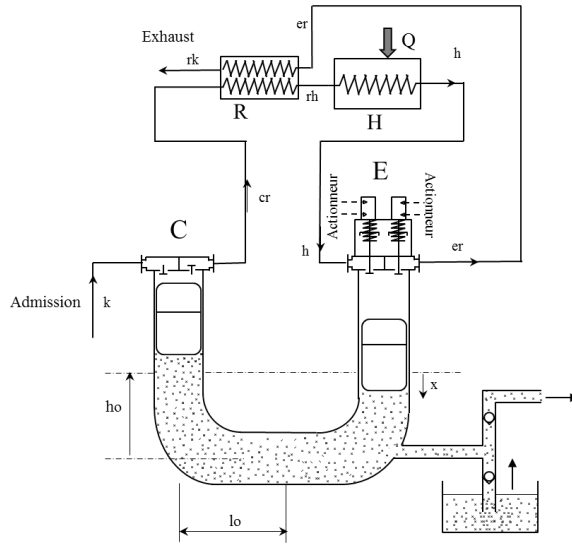

Fig. 7. The single U-tube free liquid piston Ericsson engine with hydraulic energy extraction.

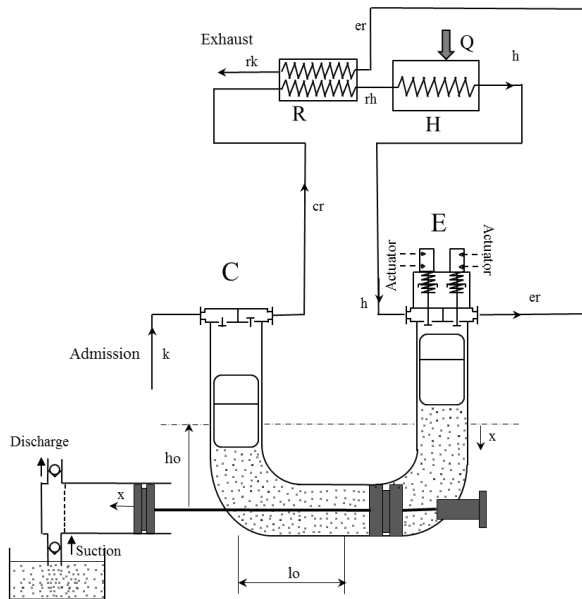

Fig. 8. The single U-tube free liquid piston Ericsson engine with hydraulic energy extraction by mechanical pumping.

3.3.3 Energy extraction by embedded electrical generator

Finally, it is also possible to extract the useful energy by means of an electrical generator directly embedded in the U-tube. Figure 9 presents a configuration with a linear alternator. The solid piston in the bottom of the U-tube carries a permanent magnet which forms the moving part of the linear alternator.

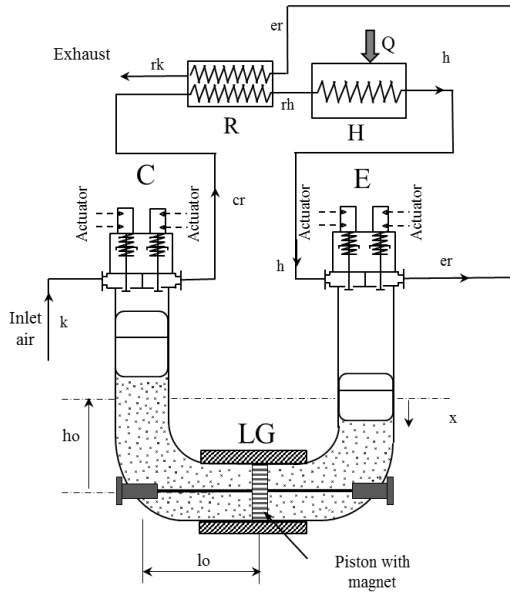

Fig. 9. The single U-tube free liquid piston Ericsson engine with a linear generator.

Another possibility is to place a small hydraulic turbine in the U-tube. This turbine drives an embedded generator. With a suitable kinematic mechanism, it is possible to ensure that energy is extracted by the turbine only during the expansion phase of the working fluid, with the turbine rotating freely on its shaft, without driving the generator, as the working fluid flows from the compression space to the expansion space.

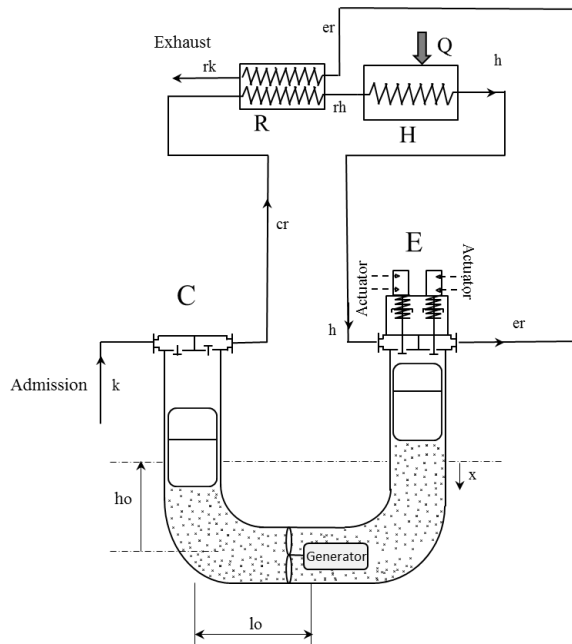

Fig. 10. The single U-tube free liquid piston Ericsson engine with a water turbine driving a generator.

4 Modelling results

The suitability and feasibility of the different Ericsson liquid piston engine configurations presented in Section 2 must be carefully assessed, in relation to the intended application. In the case of the free liquid piston configuration, designing a system with stable operation can be difficult or lead to technologically unacceptable solutions.

A model has been developed to describe the behaviour of the free liquid piston Ericsson engine equipped with a linear generator as presented in Fig. 9 [29]. The main characteristics of the modelled system are resumed in Table 1.

Table 1. Main characteristics of the modelled system.

Geometrical data	
Horizontal tube length, l_0	0.3 m
Equilib. liquid height, h_0	0.3 m
Tube diameter, D	0.175 m
Expansion relative dead volume, $V_{d,exp}$	0.95 -
Compression relative dead volume, $V_{d,comp}$	0.4 -
Maximum piston stroke, S	0.225 m
Expander valve timing	
Inlet Valve Opening (IVO)	TDC=0 m
Inlet Valve Closing (IVC)	0.08 m
Exhaust valve opening (EVO)	BDC=0.225 m
Exhaust valve Closing (EVC)	0.174 m
Compressor valve timing	
Inlet Valve Opening (IVO)	0.08 m
Inlet Valve Closing (IVC)	BDC=0 m
Exhaust valve opening (EVO)	0.138m
Exhaust valve Closing (EVC)	0.175 m
Operation data	
Working fluid	air
Liquid	water
Heat recovery effectiveness, ϵ_R	0.85
Comp. inlet temperature, T_k	300 K
Heater outlet temperature, T_h	633.2 K
Comp. inlet pressure, p_k	100 kPa
Expander outlet pressure, p_{rk}	100 kPa
Solid piston mass, m_p	10 kg
Linear Generator data	
Thrust constant, K_f	74.4 N A ⁻¹
Back EMF constant, K_e	49.6 V/(ms ⁻¹)
Stator resistance, r_s	7 Ω
Stator inductance, L	17.04 mH
External load, R_{LG}	40 Ω

With this characteristics, a stable operation of the system has been obtained by modelling, with a free piston travel of 0.2 m, within the maximum stroke of 0.225 m, and an operating frequency of 4 Hz. Fig. 11 presents the instantaneous pressure in the compression and the expansion space as a function of time. It can be seen that, in the first half of the cycle, the travel of the free liquid piston from the expansion space to the compression space is first driven by the pressure force, and then by the inertia forces, the pressure in the compression space being higher than in the expansion space, acting thus

against the motion of the piston. The same phenomenon occurs in the second half of the cycle when the free liquid piston moves back from the compression space to the expansion space. However, this phenomenon is amplified, as the pressure difference opposing the movement of the piston is greater when the liquid piston moves from the compression to the expansion space.

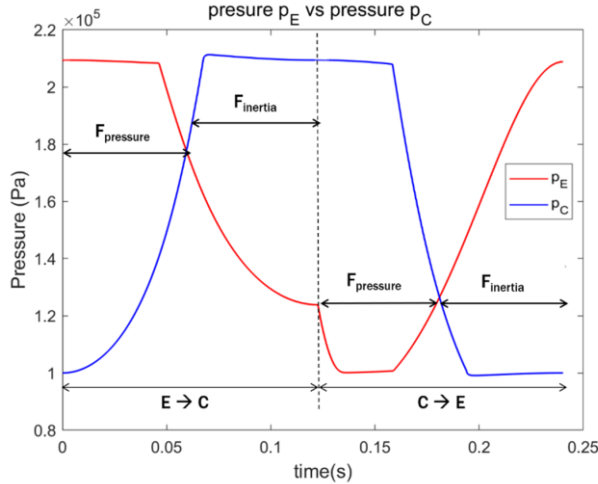

Fig. 11. Instantaneous pressure in the expansion and the compression spaces of the modelled engine.

In order to ensure the travel back of the liquid piston from the compression space to the expansion space, a delay has to be ensured in the closing of the exhaust valve of the compression space, as indicated on the indicator diagram of Fig. 12 (left).

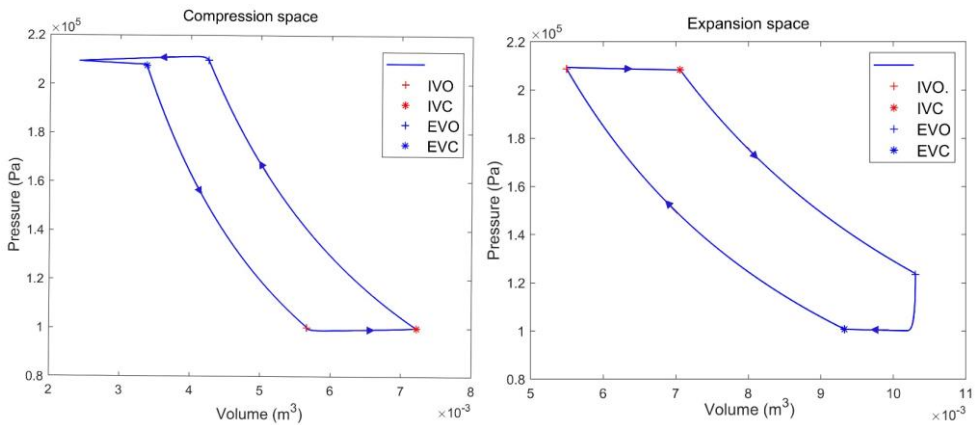

Fig. 12. Indicator diagram (pressure-Volume) of the compression chamber and expansion chamber.

The discharge valve opens as soon as the discharge pressure is obtained in the compression space, when the piston moves from the expansion to the compression space (point denoted + EVO, in Fig. 12, left). But actually, the discharge valve is still open for a while when the free liquid piston moves from the compression space to the expansion space (delay in closing the discharge valve up to the point denoted * EVC, in Fig. 12, left). The influence of the delay in the closing of the relief valve on the engine operation is to reduce the mass flow out of the compressor and to allow to complete the recompression phase in the expansion cylinder. This delay has a gas spring effect like bounce spaces in free piston internal combustion engine linear generators. Table 2 presents the cycle averaged

performance of the modelled engine. It can be seen that a net indicated power of 270 W has been obtained with a thermal efficiency of 27 %. The air mass flow rate in the engine is 7.4 10⁻³ kg/s.

Table 2. Cycle averaged thermodynamics performance of the engine.

$\dot{W}_{ind,c}$ [W]	$\dot{W}_{ind,E}$ [W]	$\dot{W}_{ind,net}$ [W]	\dot{Q}_H [W]	\dot{m} [g/s]	η_{th} [%]
543.16	-813.24	270.08	996.89	7.42	27.09

5 Conclusion

When it comes to the conversion of renewable energy sources (solar, biomass), the only existing technology with liquid piston is the Fluidyne which proved to have poor energy performance. In order to overcome this difficulty, new configurations of Liquid Piston Ericsson Engines are proposed. Simulation results show that the configuration with a free piston coupled to a linear generator has a stable behaviour with a good energy performance. Therefore, a prototype of the simulated free liquid piston Ericsson engine is under construction.

References

1. IEA, Key World Energy Statistics 2020, Paris, 2020. [Online]. Available: [//www.iea.org/reports/key-world-energy-statistics-2020](http://www.iea.org/reports/key-world-energy-statistics-2020).
2. T. Finkelstein, A. J. Organ, *Air engines* (London: Professional Engineering Publishing Ltd, 2001).
3. C. D. West, *The Fluidyne heat engine* (Harwell, UK, 1971).
4. C. D. West, *Liquid Piston Stirling Engines* (Van Nostrand Reinhold Company Inc, 1983).
5. C. D. West, Dynamic analysis of the Fluidyne, *Proceedings of the 18th Intersociety Energy Conversion Engineering Conference* (1983).
6. O. R. Fauvel, C. D. West, Excitation Of Displacer Motion In A Fluidyne: Analysis And Experiment, *Proceedings of the 25th Intersociety Energy Conversion Engineering Conference*, **5** 336–341, (1990) doi: 10.1109/IECEC.1990.747973.
7. H. G. Elrod, The Fluidyne heat engine: how to build one, how it works, *Conference report*, USA (1974).
8. A. D. Geisow, The onset of oscillations in a lossless Fluidyne, *Harwell*, UK (1976).
9. C. W. Stammers, The operation of the Fluidyne heat engine at low differential temperatures, *J. Sound Vib.* **63** 507–516 (1979) doi: 10.1016/0022-460X(79)90826-5.
10. C. D. West and R. B. Pandey, Laboratory prototype Fluidyne water pump, *Harwell*, UK (1981). [Online]. Available: <https://www.osti.gov/biblio/5052839>.
11. R. Ahmadi, H. Jokar, and M. Motamedi, A solar pressurizable liquid piston Stirling engine: Part 2, optimization and development, *Energy* **164** 1200–1215 (2018) doi: 10.1016/j.energy.2018.08.197.
12. J. W. Mason, J. W. Stevens, Design and construction of a solar-powered Fluidyne test bed, *International Mechanical Engineering Congress & Exposition IMECE2*, (2011).

13. Y. W. Wong, K. Sumathy, Solar thermal water pumping systems: a review, *Renew. Sustain. Energy Rev.* **3** 185–217(1999) doi: 10.1016/S1364-0321(98)00018-5.
14. G. C. Bell, Solar powered liquid piston Stirling cycle irrigation pump, *Research Report*, Center for Environmental Research and Development, New Mexico Univ., USA (1979).
15. J. W. Mason, J. W. Stevens, Characterization of a solar-powered Fluidyne test bed, *Sustain. Energy Technol. Assessments* **8** 1–8 (2014) doi: 10.1016/j.seta.2014.06.007.
16. H. M. Goudarzi, M. Yarahmadi, M. B. Shafii, Design and construction of a two-phase fluid piston engine based on the structure of Fluidyne, *Energy* **127** 660–670, (2017) doi: 10.1016/j.energy.2017.03.035.
17. K. Wang, S. R. Sanders, S. Dubey, F. H. Choo, F. Duan, Stirling cycle engines for recovering low and moderate temperature heat: A review, *Renew. Sustain. Energy Rev.* **62** 89–108 (2016) doi: 10.1016/j.rser.2016.04.031.
18. T. C. B. Smith, Power dense thermofluidic oscillators for high load applications, *2nd Int. Energy Convers. Eng. Conf.* **3** 1889–1903 (2004) doi: 10.2514/6.2004-5758.
19. C. N. Markides, T. C. B. Smith, A dynamic model for the efficiency optimization of an oscillatory low grade heat engine, *Energy* **36** 6967–6980 (2011) doi: 10.1016/j.energy.2011.08.051.
20. R. Solanki, A. Galindo, C. N. Markides, Dynamic modelling of a two-phase thermofluidic oscillator for efficient low grade heat utilization: Effect of fluid inertia, *Appl. Energy* **89** 156–163 (2012) doi: 10.1016/j.apenergy.2011.01.007.
21. C. N. Markides, A. Osuolale, R. Solanki, G. B. V. Stan, Nonlinear heat transfer processes in a two-phase thermofluidic oscillator, *Appl. Energy* **104** 958–977 (2013) doi: 10.1016/j.apenergy.2012.11.056.
22. C. N. Markides, R. Solanki, A. Galindo, Working fluid selection for a two-phase thermofluidic oscillator: Effect of thermodynamic properties, *Appl. Energy* **124** 167–185 (2014) doi: 10.1016/j.apenergy.2014.02.042.
23. E. Orda, K. Mahkamov, Development of ‘low-tech’ solar thermal water pumps for use in developing countries, *J. Sol. Energy Eng. Trans. ASME* **126** 768–773 (2004) doi: 10.1115/1.1668015.
24. K. Mahkamov, E. Orda, B. Belgasim, I. Makhkamova, A novel small dynamic solar thermal desalination plant with a fluid piston converter, *Appl. Energy* **156** 715–726, (2015) doi: 10.1016/j.apenergy.2015.07.016.
25. R. P. Klüppel, J. M. M. Gurgel, Thermodynamic cycle of a liquid piston pump, *Renew. Energy* **13** 261–268 (1998) doi: 10.1016/S0960-1481(97)00049-9.
26. H. Jokar, A. R. Tavakolpour-Saleh, A novel solar-powered active low temperature differential Stirling pump, *Renew. Energy* **81** 319–337 (2015) doi: 10.1016/j.renene.2015.03.041.
27. M. Ndamé Ngangué, P. Stouffs, Dynamic simulation of an original Joule cycle liquid pistons hot air Ericsson engine, *Energy* **190** (2020), doi: 10.1016/j.energy.2019.116293.
28. R. Chouder, A. Benabdesselam, P. Stouffs, Modélisation dynamique « intracycle » d’un moteur à air chaud ERICSSON à piston liquide, *Actes du Congrès de la Société Française de Thermique* **125** (2020) doi: 10.25855/SFT2020-125
29. R. Chouder, P. Stouffs, A. Benabdesselam, Dynamic Modeling of a Free Liquid Piston Ericsson Engine (FLPEE), *Proceedings of the ECOS conference* **203** (2021).
30. R. P. Pescara, Motor compressor apparatus, *Patent N° 1 657 641* (1928).