

Supply chain analysis of incense in North Tapanuli Regency

Sonya Naibaho and Yosef Manik*

Engineering Management Study Program, Faculty of Industrial Technology, Institut Teknologi Del, Toba, Indonesia, 22381

Abstract. Incense (*Styrax sumatrana* J. J. Sm) is a non-timber forest commodity in North Tapanuli Regency. This study aims to map out incense supply chain in North Tapanuli, to analyze the stakeholders who play role, and to determine the added value of incense throughout its supply chain models. Using snowball sampling, this study found different supply chain models and stakeholders who play role, namely farmers, village collectors, large village collectors, sub-district collectors, district collectors, agents, exporters, and consumers. Calculation of the added value of incense for each stakeholder throughout the supply chain was carried out using the Hayami method. The results indicate that farmers who sell their crops to sub-district collectors get the highest added value with R/C ratio of 2.18. Further, the stakeholders were also mapped out into quadrants based on power and interest in incense value chain. Unexpectedly, stakeholders who have high influence and interest are the collectors, while the farmers are only the subjects, namely actors who are high in terms of interest but low in influence. The result of this study is useful for developing of incense trade system that favors its community stakeholder.

1 Introduction

Incense (*Styrax sumatrana* J. J. Sm) is an endemic plant and mainstay commodity from Batak area in North Sumatra [1]. Incense from the *Styracaceae* is a sap-producing plant as a non-timber forest product that has high economic value. In general, only 4 types of incense are cultivated and have high selling values, that is Toba Incense (*Styrax parallel neurum* PERK), Durame Incense (*Styrax benzoin* DRYAND), Bulu Incense (*Styrax benzoin var. hiliferum*) and Siam incense (*Styrax tonkinensis*)[2]. In 2020, the planting area of incense in North Tapanuli is 16,077 ha, being the area that has the highest incense plantation area in North Sumatra. To get incense, farmers will tap incense trees that are 6-7 years old [3]. The incense harvest will be carried out 3-4 months after the tapping. The harvest of incense occurs once a year in December, January, and February. Raw incense which is rarely processed into a product that has added value and selling value in Sumatra, will then be sent to Java. After going through packing and screening, the incense will be exported abroad.

* Corresponding author: yosef.manik@del.ac.id

Based on the initial research that has been done, it is known that there is no processing of incense in the North Tapanuli area. The farmers will directly sell their crops to the collectors and in determining the selling price the bargaining power of the farmers is low enough so that the price they receive is more dominantly determined by the collectors who adjust the price to the request of the agent or company. Until now, there has been no systematic study that maps out the supply chain flow of incense in North Tapanuli and to know who has a role in the supply chain flow of incense.

Several studies related to supply chains and incense have been carried out by previous researchers. Research conducted by Raya [4] focuses on the marketing of incense in the Humbang Hasundutan area. This study analyzes the marketing pattern of incense and calculates the value of the marketing margin obtained for each marketing pattern. Then the researchers gave advice to the incense farmers based on a SWOT analysis. Research related to supply chains was carried out by Sorta Grace Pardede analyzing the Andaliman supply chain in Toba Samosir, Mestika Silalahi [5] analyzing the pineapple supply chain in Sipahutar, and Berlian Napitupulu [6] analyzing the corn supply chain in Toba Samosir. The supply chain is obtained using a descriptive method that shows the flow of products from farmers to consumers in several flow models. The supply chain also shows each stakeholder or actor who plays a role in the supply chain. By analyzing the supply chain, researchers can describe product flows, information flows, and financial flows. Researchers will also analyze how much profit is earned by farmers by calculating added value and also marketing margins. The added value obtained by farmers will be calculated using the hayami method which involves income and expenses while running a farming business. Marketing margin is calculated by taking into account the costs incurred for product marketing purposes and the percentage of profit.

Through previous research and research that has been done, it shows that there has never been any research related to the incense supply chain in North Tapanuli. For this reason, it is very necessary to conduct research that can describe the supply chain of incense in North Tapanuli Regency and to analyze the extent to which this sector affects the economy of stakeholders. This study aims to describe the supply chain of incense in North Tapanuli, by analyzing each actor involved in the supply chain. In this study, the added value of incense will also be calculated and will also test the feasibility or efficiency of farming by calculating the R/C ratio of incense farmers. In this study, strategic recommendations will also be given to increase the added value of Incense for Incense farmers in North Tapanuli Regency using the SWOT analysis method.

2 Research methods

This research was conducted in North Tapanuli between January and April 2021, in the sub-districts of Pangaribuan, Garoga, and Sipahutar. These sub-districts were selected since they are the highest incense producing sub-districts in North Tapanuli Regency.

2.1 Sampling

The sampling method used in this study is the snowball sampling method. The snowball sampling method is a method for identifying, selecting and taking samples in a continuous network or chain of relationships or can be analogous to a snowball that starts with a small snowball and will gradually increase in size due to the addition of snow when rolled in a snowflake [7,8]. Forty-five informants, consisting of incense farmers, collectors, and participated in this study.

2.2 Data collection

This study collected data from primary and secondary sources.

2.2.1 Primary data

To obtain primary data, the authors conducted interviews and direct field observations. Interviews were conducted with relevant agencies and stakeholders in the incense industry. The data collected during interview are in the role of actors in the incense supply chain, the value obtained by each actor, and data related to the problems studied. The data obtained will be used to describe the supply chain of incense, the selling and buying prices of incense, as well as an overview of the research location.

2.2.2 Secondary data

To obtain secondary data, a literature study will be conducted to obtain written information about incense plants and other information. In this study, secondary data that will be used is information from the Department of Agriculture and Plantations, the Central Bureau of Statistics of North Sumatra, and other literature. The secondary data include planting area and price of incense.

2.3 Data processing

In this study there are two analytical methods that will be used, that is qualitative methods and quantitative methods. Qualitative methods were used to identify each actor in the supply chain flow and mapped out the stakeholders into quadrants based on their power and interest in incense value chain. Quantitative methods were used to analyze the added value of Incense using the Hayami method. Hayami method produces added value received in each of its elements. This method is easy to understand and provides detail information for business actors [9,10].

2.3.1 Supply chain analysis

Supply chain is a series of activities that perform an interrelated function starting from the procurement of raw materials to delivering products to the hands of customers [11,12,13]. The supply chain analysis will start from the incense farmer to the consumer. The incense supply chain analysis was conducted to identify the incense supply chain map, the stakeholders involved, and the interrelationships between stakeholders in the Incense supply chain.

2.3.2 Value added analysis

Value added is the difference between the income obtained from the sale of products or services and the costs for purchasing the materials needed to produce these products or services. According to Hayami [14,15] the added value of a product occurs due to 2 things:

a. Value added during the processing

During the processing there are two factors that affect the added value, that is technical factors in the form of production capacity, the number of materials and labor, and also market factors in the form of output, labor wages, and raw material prices.

b. Value added during the marketing process

Value added distribution has a relationship with the technology used in the production process, the quality of the workforce in the form of skills and expertise, and also the quality of the raw materials.

The increase in incense added value can occur at any flow in the incense supply chain in the North Tapanuli during the marketing process.

The Hayami method [14] will also be used to determine the R/C ratio of each actor to assess the feasibility or efficiency of the business owned by the stakeholders [16]. With the following criteria:

- a. If the R/C ratio is >1 , then the business is feasible or efficient to run.
- b. If the R/C ratio <1 , then the business is not feasible or efficient to run.
- c. If the R/C ratio = 1, then the state of the business has reached the break-even point or has not been efficient to run.

2.3.3 Stakeholders analysis

In this study, the stakeholder is anyone who has an interest and influence on incense in North Tapanuli. The data to be used in stakeholder mapping is obtained by conduct observations and interviews with stakeholders such as farmers, collectors, agent, exporters, consumers, the government, and PT. Toba Pulp Lestari (TPL). Each actor will be classified based on the level of influence and importance they have, namely key player (high influence and importance), subject (low influence, however high importance), context setter (high influence, but low importance), and crowd (low influence and importance).

3 Result and Discussion

3.1 Supply Chain System

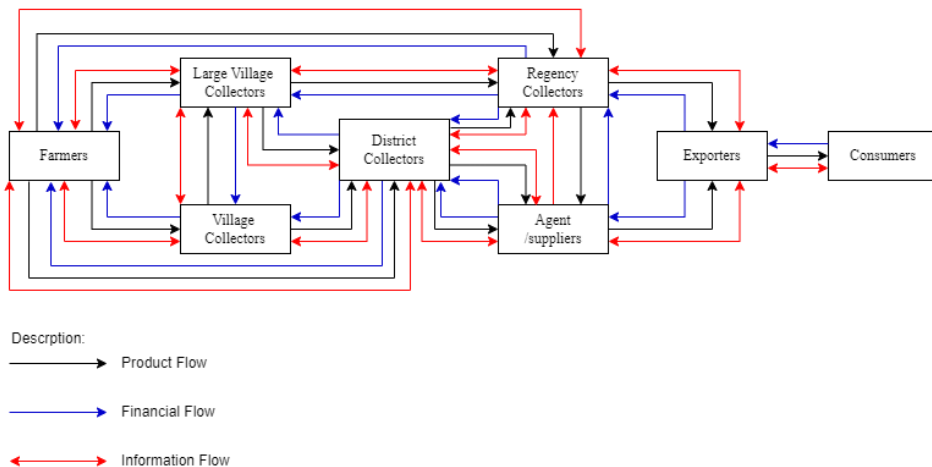

Fig. 1. Incense Supply Chain Flow

Actors or stakeholders in the supply chain flow of incense in North Tapanuli Regency are farmers, village collectors, sub-district collectors, district collectors, agents/suppliers, exporters, and consumers. Farmers have an important role in the supply chain flow of frankincense as a producer incense as a raw material. Village collectors are collectors who live in farmers' villages and buy incense only from farmers in the village. Sub-district

collectors are collectors who buy incense from farmers and village collectors by coming to villages. District collectors are collectors of incense in large quantities and receive incense from other districts. The agent acts as an extension of the collector to the company or acts as a provider of raw materials for processing products made from incense. Exporters play a role in exporting incense abroad, because in general incense is not processed domestically into finished products. The flow of the incense supply chain in North Tapanuli can be seen in Figure 1 below. In Supply chain these three flows are collaborated, coordinated and integrated each other [17,18].

3.1.1 Product Flow

The product flow is incense sap that comes from farmers. After harvesting, the farmers immediately sell their crops to collectors. Then the collector will dry the incense for 6-7 days. Every harvest season, village collectors or large village collectors will receive 25-100 kg, sub-district collectors are 300kg-500kg, district collectors 3-7 tons. After collecting, sub-district collectors and district collectors will distribute incense according to the number of requests of agents or the exporters.

3.1.2 Financial Flow

The financial flows is essential in supply chain [19] and need to be managed in a coordinated way [20]. It starts with exporters and agents who make purchases from sub-district collectors and district collectors. The two actors would then pay money to the large village collectors and village collectors, then finally to the farmers. To cultivate land and care for the incense trees, the farmers would use previous harvest yields and also get loans from collectors. After doing harvest, farmers would give their crops to collectors who give loans.

3.1.3 Information Flow

The flow of information that occurs between supply chain actors is information about the fluctuation of prices and the demand for incense. Information flows allow the various supply chain partners to coordinate their long-term plans [21], and to control the flow of goods and materials up and down the supply chain [22]. The flow of information about price fluctuations will involve members who are involved in financial flows, while the flow of the demand for incense will flow from agents and exporters and then to the collectors. The weakness of the flow of information in the incense supply chain is that there is no fixed price setting among collectors. This is because the collectors only differentiate the price through the size and color of the incense according to their perspectives. This causes sometimes there is quite a big price difference between the collectors.

3.2 Added Value

3.2.1 Added Value of Incense to Farmers

The added value to farmers will be calculated by analyzing the supply chain. In this study, researchers analyzed four supply chain model, that is (i) through village collectors, (ii) through large village collectors, (iii) through sub-district collectors, and (iv) through district collectors.

a. Harvest Period

In the calculation of the added value in harvest period, it is assumed that the area to be harvested is 1 ha (300-500 stems) with the number of harvests in the harvest period (once in 1 year) as much as 50 kg. The calculation of added value to farmers in harvest period can be seen in Table 1 below:

Table 1. Analysis of the Added Value of Incense to Farmers during Harvest

Land area 1 ha for 50 kg of “Kemenyan Nauli” incense (300-500 stems)					
No.	Variables	Farmer			
		Village Collector	Large Village Collector	Sub-district Collector	District Collector
1	Output/Product total (kg/period)	50	50	50	50
2	Input/Raw material (kg/period)	50	50	50	50
3	Input/Labor (HOK/period)	15	15	18	18
4	Conversion Factor (kg output/kg raw materials)	1	1	1	1
5	Labor coefficient (HOK/kg raw materials)	0.3	0.3	0.36	0.36
6	Output price (IDR/kg)	210,000	225,000	250,000	270,000
7	Average labor wage (IDR/hour)	7,500	7,500	7,500	7,500
Profit					
8	Raw material input price (IDR/kg)	110,000	110,000	110,000	110,000
9	Other material input contribution (IDR/kg)	2,000	2,000	2,000	6,000
10	Output value (IDR/kg)	210,000	225,000	250,000	250,000
11	a. Added value (IDR/kg)	98,000	113,000	138,000	134,000
	b. Value added ratio (%)	47%	50%	55%	54%
12	Labor income (IDR/hour)	2,250	2,250	2,700	2,700
	Labor share (%)	2%	2%	2%	2%
13	Profit (IDR/kg)	95,750	110,750	135,300	131,300
	Profit rate (%)	46%	49%	54%	57%
Service Materials and Each Factor of Production					
	Margin (IDR/kg)	100,000	115,000	140,000	140,000
	Labor income (%)	2%	2%	2%	2%
14	Other material input contribution (%)	2%	2%	1%	2%
	Entrepreneur's profit (%)	96%	96%	97%	94%
	R/C Ratio	1.84	1.97	2.18	2.11

From the calculation of added value using the Hayami method above, it can be seen that the added value obtained by farmers varies based on the marketing channels used by farmers. At harvest time, for farmers who sell their crops to sub-district collectors will get the highest added value, that is IDR138,000/kg or 55% of the output.

b. Post-harvest

In calculating the added value for post-harvest, i.e. taking the rest of the harvest, it is assumed that the area to be harvested is 1 ha (300-500 stems) with a total yield of 15 kg. The calculation of added value to farmers in post-harvest can be seen in Table 2 below:

Table 2. Analysis of the Added Value of Incense to Farmers in Post-Harvest

Land area 1 ha for 15 kg of Kemenyan Tahir (300-500 stems)					
No.	Variables	Farmer			
		Village Collector	Large village Collector	Sub-district Collector	District Collector
1.	Output/Product total (kg/period)	15	15	15	15
2.	Input/Raw material (kg/period)	15	15	15	15
3.	Input/Labor (HOK/period)	5	5	6,25	6,25
4.	Conversion Factor (kg output/kg raw materials)	1	1	1	1
5.	Labor coefficient (HOK/kg raw materials)	0,333	0,333	0,417	0,417
6.	Output price (IDR/kg)	90,000	95,000	100,000	120,000
7.	Average labor wage (IDR/hour)	12,000	12,000	12,000	12,000
Profit					
8	Raw material input price (IDR/kg)	70,000	70,000	70,000	90,000
9	Other material input contribution (IDR/kg)	500	500	500	4,500
10	Output value (IDR/kg)	90,000	95,000	100,000	120,000
11	a. Added value (IDR/kg)	19,500	24,500	29,500	25,500
	b. Value added ratio (%)	22%	26%	30%	21%
12	Labor income (IDR/hour)	4,000	4,000	5,000	5,000
	Labor share (%)	21%	16%	17%	20%
13	Profit (IDR/Kg)	15,500	20,500	24,500	20,500
	Profit rate (%)	0.172	0.216	0.245	0.171
Service Materials and Each Factor of Production					
	Margin (IDR/kg)	20,000	25,000	30,000	30,000
	Labor income (%)	20%	16%	17%	17%
14	Other material input contribution (%)	3%	2%	7%	7%
	Entrepreneur's profit (%)	78%	82%	82%	68%
	R/C Ratio	1.21	1.28	1.32	1.21

At post-harvest, farmers can produce incense with clean quality 3- 5 kg per week. From the calculation of the added value above, it can be seen that in post-harvest period, farmers who sell their crops to sub-district collectors, will also get the highest added value.

3.2.2 Added Value of Incense to Collector

Incense marketing in North Tapanuli involves collectors, that is village collectors, large village collectors, sub-district collectors, and district collectors. The calculation of the added value of frankincense for collectors can be seen in Table 3 below.

Table 3. Analysis of The Added Value of Incense for Collectors

No.	Variables	Village Collector	Large village Collector	Sub-district Collector	District Collector
1	Output/Product total (kg/period)	100	200	500	3,000
2	Input/Raw material (kg/period)	100	200	500	3,000
3	Input/Labor (HOK/period)	10	10	30	84
4	Conversion Factor (kg output/kg raw materials)	1	1	1	1
5	Labor coefficient (HOK/kg raw materials)	0.1	0.05	0.06	0.028
6	Output price (IDR/kg)	260,000	270,000	320,000	320,000
7	Average labor wage (IDR/hour)	7,500	8,125	9,375	10,000
Income Profit					
8	Raw material input price (IDR/kg)	230,000	245,000	260,000	280,000
9	Other material input contribution (IDR/kg)	2,000	2,000	1,000	300
10	Output value (IDR/kg)	260,000	270,000	320,000	320,000
11	a. Added value (IDR/kg)	28,000	23,000	59,000	39,700
	b. Value added ratio (%)	11%	9%	18%	12%
12	Labor income (IDR/hour)	750	406.25	562.5	280
	Labor share (%)	3%	2%	1%	1%
13	Profit (IDR/kg)	27,250	22,593.75	58,437.5	39,420
	Profit rate (%)	10%	8%	18%	12%
Service Materials and Each Factor of Production					
	Margin (IDR/kg)	30,000	25,000	60,000	40,000
	Labor income (%)	3%	2%	1%	1%
14	Other material input contribution (%)	7%	8%	2%	1%
	Entrepreneur's profit (%)	91%	90%	97%	99%
	R/C Ratio	1.12	1.09	1.22	1.14

From the results of the calculation of added value using the hayami method, it is known that the district collectors are collectors who obtain high added value, which is IDR 59,000/kg. The fact that all R/C ratio being greater than 1 indicate that the business run by all collectors is an efficient and feasible business to run. However, all the R/C ratio of collectors are lower than that of the farmers, meaning that the profit to the farmers is bigger than that to the collectors.

3.3 Stakeholders Analysis

Stakeholders have been identified and classified into four groups based on on-site circumstances and based on prevailing theories [23,24]. The classification is carried out based on the level of interest and influence of each stakeholder on the incense commodity [12].The result of the stakeholder mapping out can be seen in Figure 2 below.

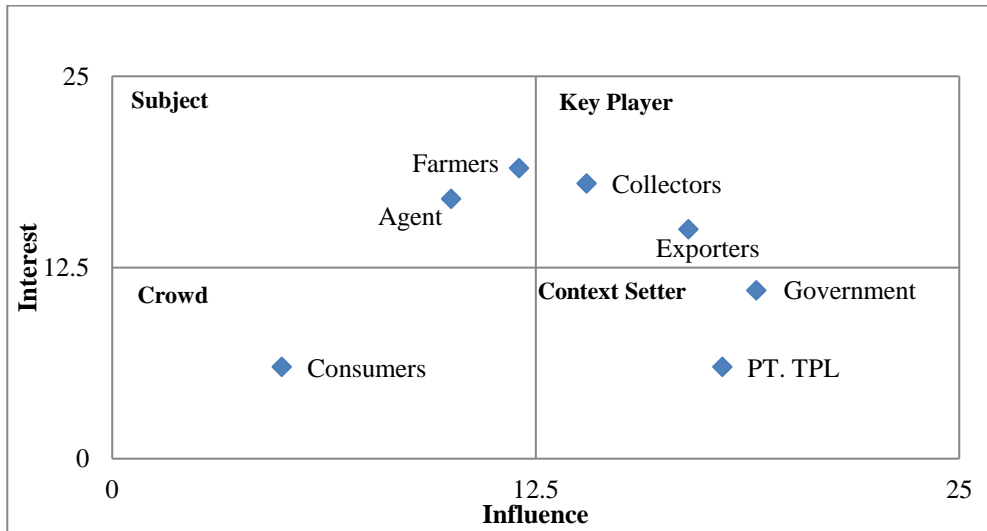

Fig. 2. Stakeholders' analysis.

3.3.1 Key Player

In the incense supply chain in North Tapanuli, the key players included are collectors and exporters. Collectors are included in the key player category because they have high interest, that is to get high profits and influence in determining the price of incense that will be received by farmers. Exporters are also a key player because they have a high influence on change in the price of incense in the market and by exporting, incense has a fairly high price.

3.3.2 Subject

The stakeholders included in the subject category are farmers and agents. Both of these stakeholders have a high interest, that is to obtain profits/commissions from incense or to meet the needs of each actor, while the influence they have for value addition of incense is quite low. The low influence of these two actors is due to the weak position of actors in determining decisions in the supply chain. However, farmers should be included in the key player category because farmers are the main actors in producing incense. The low position of farmers' influence in the supply chain will be a weakness that farmers have in developing incense commodities. To increase the influence that farmers have, it can be done by providing counseling to farmers, increasing cooperation between farmers and the incense processing industry, and also providing equal and fair information about the fluctuations in the price of incense in the market.

3.3.3 Crowd

Stakeholders who included to the crowd category are consumers. In mapping the stakeholders in the incense supply chain, consumers have low importance and influence. Based on the interests, motivations, and influence of consumers, consumers should be included in the context setter category, because they are the end users of processed incense. The causes of the low interest and influence from consumers is the lack of popularity of

incense processed products. There are still many people who do not know other uses of incense [16].

3.3.4 Context Setter

For the context setter category, the North Tapanuli Government and PT. Toba Pulp Lestari (TPL) is a stakeholder who included to this category. The North Tapanuli government is included to this category because they have high influence but low importance. This is because the North Tapanuli Government is not aware of the various benefits and potentials of incense in North Tapanuli. The North Tapanuli government should be included in the key player category because they have a high influence and interest in managing and adding incense added value. PT. Toba Pulp Lestari (TPL) is included in this category because they have a small interest in incense but has a fairly high influence on incense. This can be seen from the transition of several lands in North Tapanuli Regency which were previously customary forests or land where people took forest products provided by nature such as incense into industrial plantation forests. This transition resulted in many people changing jobs which were previously incense farmers due to the presence of PT. TPL, which is working on land included in the HPHTI, is planting Eucalyptus to meet their economic and company needs. Position of PT. This TPL will be a threat to the incense commodity in North Tapanuli Regency.

4 Conclusion

From the results of the analysis and discussion, it can be concluded that there are four models of incense supply chain flow in North Tapanuli, that is (i) through village collectors, (ii) through large village collectors, (iii) through sub-district collectors, and (iv) through district collectors. It is also found that there are eight actors or stakeholders involve in the supply chain, that is farmers, village collectors, village big collectors, district collectors, regency collectors, agents/suppliers, companies, and consumers. The flow of incense will start from farmers and will be marketed involving all actors in the incense supply chain to reach consumers.

Based on the added value analysis using Hayami method, the stakeholder who get the highest benefits in the frankincense supply chain is incense collectors at the district levels and the stakeholder who get the lowest profits is the farmers who sell their harvests directly to village collectors.

The analysis of the Hayami method on farmers shows that farmers who sell their corps directly to district collectors will get the highest added value, that is IDR 13,8000/kg for the nauli type and IDR 29,500/kg for the tahir type. The value-added analysis at the collector level shows that district collectors get a higher added value among all collectors, which is around IDR 59,000/kg.

From the results of stakeholder mapping out, there are three stakeholders who should not be included in the current category, that is farmers, the North Tapanuli Government, and consumers. The inaccuracy of this position shows the weaknesses of the stakeholders that make their level of interest/influence low. Especially farmers who have an important role and high interest in incense. Farmers and other stakeholders must establish good cooperation to increase the development of incense in North Tapanuli. Utilization of resources and developing technology can be an alternative that can be used to develop incense commodities.

References

1. M. H. Saputra and H. S. Lee, *Sustain.* **13**, 1 (2021).
2. I. Azhar, Z. Nasution, Delvian, Agussabti, Riswan, S. Sidabukke, M. Sianipar, and M. F. Srena, in *IOP Conf. Ser. Earth Environ. Sci.* (Institute of Physics Publishing, 2019).
3. BPS Kabupaten Tapanuli Utara, *Kabupaten Tapanuli Utara Dalam Angka 2020* (Badan Pusat Statistik Kabupaten Tapanuli Utara, 2020).
4. B. R. Simanjuntak, Y. Afifuddin, and R. Batubara, *Peronema For. Sci. J.* **1**, 1 (2012).
5. M. Silalahi and Y. Manik, *Talent. Conf. Ser. Energy Eng.* **2**, (2019).
6. B. Napitupulu and B. A. H. Siboro, *Talent. Conf. Ser. Energy Eng.* **2**, (2019).
7. J. Audemard, *BMS Bull. Sociol. Methodol. Bull. Methodol. Sociol.* **145**, 30 (2020).
8. M. C. Alam and T. Supriana, in *IOP Conf. Ser. Earth Environ. Sci.* (2018).
9. A. Brilliantina, E. K. Novitasari, B. Y. Pratiwi, and I. R. A. Sasmita, in *Second Int. Conf. Food Agric.* (2019), pp. 624–628.
10. K. F. Kodrat, S. Sinulingga, H. Napitupulu, and R. A. Hadiguna, *Int. J. Adv. Res.* **6**, 713 (2018).
11. T. M. Simatupang, *Manajemen Rantai Nilai Dalam Rantai Kreatif* (Majelis Guru ITB, Bandung, 2010).
12. S. Raum, *Ecosyst. Serv.* **29**, 170 (2018).
13. D. S. Levi, P. Kaminsky, and E. S. Levi, *Designing and Managing the Supply Chain Concepts, Strategies and Case Studies* (Mc Graw Hill, 2008).
14. Y. Hayami, *Agricultural Marketing and Processing in Upland Java* (CGPRT Centre, 1987).
15. M. T. Sundari, Setyowati, and R. K. Adi, in *IOP Conf. Ser. Earth Environ. Sci.* (2021).
16. Y. Manik and B. A. H. Siboro, *Solid State Technol.* **63**, 937 (2020).
17. F. Caniato, M. Henke, and G. A. Zsidisin, *J. Purch. Supply Manag.* **25**, 99 (2019).
18. S. Li, B. Ragu-Nathan, T. S. Ragu-Nathan, and S. Subba Rao, *Omega* **34**, 107 (2006).
19. F. L. Leng and S. Zailani, *Int. J. Manag.* **29**, 293 (2012).
20. D. A. Wuttke, C. Blome, and M. Henke, *Int. J. Prod. Econ.* **145**, 773 (2013).
21. N. Madenas, A. Tiwari, C. J. Turner, and J. Woodward, *CIRP J. Manuf. Sci. Technol.* **7**, 335 (2014).
22. K. Kleab, *Int. J. Sci. Res. Publ.* **7**, 397 (2017).
23. R. Tambun and Y. Manik, *J. Eng. Sci. Res.* **2**, 39 (2020).
24. M. Slabá, *Littera Scr.* **1**, 124 (2016).