

Research on Energy-fed Suspension Control System of New Energy Vehicles Based on Energy Flow Analysis

Jiageng Ding

Case Western Reserve University, Cleveland, OH 44106, USA

Abstract. Suspension is the general name of the device that connects the conductive force between the car body and the wheels. Among them, operational stability and ride comfort are two contradictory requirements in actual driving. In the traditional vehicle suspension system, in order to maintain the ride comfort of the vehicle, the vibration energy caused by uneven road surface is usually dissipated by passive shock absorber in the form of heat. If this part of energy can be recovered in an effective way, the energy demand of the whole vehicle system can be reduced. Usually, the stiffness of semi-active suspension is constant, and the damping coefficient will change automatically with the change of driving conditions. Its advantages are simple structure, no need to consume automobile power, and the damping coefficient will change with the change of automobile driving conditions, which can effectively improve automobile riding comfort and handling stability. This paper expounds the problems encountered by traditional suspension, and analyzes the semi-automatic control strategy of regenerative suspension of new energy vehicles from the perspective of energy flow.

Key words: New energy vehicles; Energy-fed suspension control; Energy flow

1. Introduction

Suspension is the general name of the device that connects the conductive force between the car body and the wheels. As one of the most important car body components, suspension should have the following functions: supporting the whole car body or the quality of the car body; Transfer all the forces and moments between the car body and the wheels, so that the tires are as close to the road as possible, so as to minimize the change of the balance posture of the car body caused by external factors and provide good operational stability; The axle and the car body are elastically connected together, and the impact from the uneven road surface can be effectively attenuated, suppressed and isolated, so as to provide good riding comfort [1]. When the vehicle is running, the vibration caused by the uneven road surface excitation is mainly attenuated by the suspension and then transmitted to the body [2]. Although the suspension of modern automobile has various structural forms, it is generally composed of three parts: elastic element, shock absorber and guiding mechanism. In the traditional vehicle suspension system, in order to maintain the ride comfort of the vehicle, the vibration energy caused by the uneven road surface is usually dissipated by the passive shock absorber in the form of heat [3]. If this part of energy can be recovered in an effective way, the energy demand of the whole vehicle system can be reduced. The vibration energy recovery of suspension is an effective means of

automobile energy saving, and it is also one of the research hotspots of suspension technology at present. The recovered energy can not only be used to drive the vehicle, reduce fuel consumption and increase driving mileage, but also be directly used to control the suspension and reduce its energy consumption [4].

As an important part of automobile, the performance of suspension system will have a vital impact on the ride comfort and handling stability of automobile [5]. Therefore, the requirements for automobile suspension are getting higher and higher. The traditional shock absorber mainly produces damping force through the friction of internal hydraulic oil to do work to attenuate vibration [6]. When the vehicle frame and the axle move relative to each other, the hydraulic oil in the shock absorber repeatedly passes through the damping hole with the movement of the piston, and at this time, the friction between the hole wall and the oil and the internal friction of the liquid molecules form a damping force, so that the vibration energy is converted into heat energy, which is absorbed by the oil and the shock absorber shell, and then dispersed into the atmosphere [7]. Usually, the stiffness of semi-active suspension is constant, and the damping coefficient will change automatically with the change of automobile driving conditions [8]. Its advantages are simple structure, no need to consume automobile power, and the damping coefficient will change with the change of automobile driving conditions, which can effectively improve automobile riding comfort and handling stability.

* Corresponding author: davyding65@gmail.com

Energy-feeding active suspension can realize active control of suspension, recover the vibration energy dissipated by shock absorber in the form of heat energy and store it in vehicle-mounted battery, which solves the contradiction between the economy and overall performance of suspension system to some extent, making it possible for it to be widely used in the future [9]. This paper expounds the problems encountered by traditional suspension, and analyzes the semi-active control strategy of regenerative suspension of new energy vehicles from the perspective of energy flow.

2. Problems encountered by traditional suspension

At present, most vehicles mainly use passive suspension due to technical and price reasons, and research and experiments have long shown that active suspension has superior performance, which can not only control the posture and height of the car body to adapt to various road conditions, but also improve the driving stability and ride comfort of vehicles by changing the damping characteristics of the suspension. Faced with the increasing shortage of petroleum energy and soaring prices, energy waste is widespread in the automobile industry. It has become an inevitable trend to develop environmental protection and energy-saving technologies in the automobile industry. Then the effective way to reduce the energy consumption of automobiles is to recycle these wasted energy, so as to achieve the purpose of saving energy [10]. If the motor can only run in a single quadrant, then the energy can only flow in one direction, that is, forward electric or reverse electric, and it can't be changed from power generation operation to electric operation, and vice versa. If you want to make the energy flow in two directions, you can only use a four-quadrant motor, that is, you can run in the starting state or the motor state. In the traditional passive vehicle suspension system, vibration energy is damped and converted into heat energy in the form of friction, and this heat energy is finally dissipated into the atmosphere and wasted. The amount of energy dissipated by the damping element is not only related to its friction coefficient, but also closely related to the vehicle speed, road bump and body weight. Then in order to recycle this part of energy, the necessary suspension system uses an energy recovery device to replace the damping element on the traditional passive suspension, and connects it in parallel with the elastic element to finally form the vehicle suspension.

3. Control system structure and energy flow analysis

The motor actuator is in the form of ball screw combined with motor. This kind of motor actuator has the advantages of low cost, high energy feeding efficiency, good reliability, high adaptability and simple structure, which meets the requirements of suspension system. In terms of energy storage, it adopts an energy storage device that combines a large-capacity battery with an energy

storage electrolytic capacitor. Different from the ordinary active suspension, the electromagnetic energy-feedback active suspension uses the energy-feedback damper as the active actuator, and controls the actuator through the executive circuit, so as to realize the function of active control and energy recovery of the energy-feedback suspension [11]. The electric energy recovered by the motor can be quickly stored in the electrolytic capacitor and then released into the storage battery, where the electrolytic capacitor plays a buffering role and avoids charging the storage battery with a large instantaneous current. When the vehicle driving environment is poor, it is hoped that the controller will restrain the vibration caused by uneven road surface to the greatest extent, so as to achieve good vehicle driving smoothness. Therefore, at this time, the actuator control current covers all its realizable areas, and this mode is called full active energy consumption mode. The energy flow process of regenerative suspension system is shown in Figure 1.

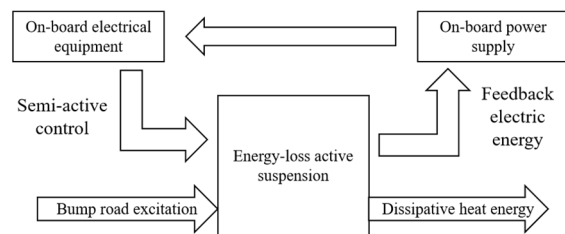

Figure 1 Energy flow process of regenerative suspension system

When the motor runs electrically, the electric energy needed is released from the electrolytic capacitor first, because the instantaneous discharge capacity of the battery is not enough to drive the motor to start with a large torque, which can not only prolong the service life of the battery, but also improve the driving capacity of the motor. By analyzing the simplified control circuit, it is known that different regions of the realizable range of control current correspond to different motor running states and energy flow states respectively. The motor used for the motor actuator of the regenerative suspension needs to meet the normal operation requirements of the whole suspension system, and the motor needs to move in the limited space between the car body and the tire, so the volume should be small. The rotating direction of the motor needs to be changed frequently and repeatedly, which requires it to have a strong ability to change direction. Because the weight of the suspension is changing, the motor must have a strong overload ability. The vibration of the car body causes the rotation of the motor to start and brake frequently, so the motor should have a small moment of inertia. When the on-board battery is too low and the requirement for road vibration suppression is not very high, the control current can be limited to be stable, so that the motor can work as a generator and charge the battery. This mode is called semi-active energy feeding mode.

4. Semi-active control of regenerative suspension

When the vehicle is running, the vibration of the vehicle is mainly caused by the irregular shape of the road surface. The greater the roughness of the road surface, the more intense the vibration of the vehicle and the worse the posture of the vehicle body. When analyzing the dynamic performance of active suspension, we must first determine what kind of road excitation to use. According to the different types of pavement, it can be divided into discrete pavement input and random pavement input. For the suspension system, the disturbance input can be expressed as pulse and step signals from the road surface, which expresses a fixed pothole [12] on the random road surface. According to common sense, this kind of disturbance signal we analyze has the characteristics of transient and sudden, so we can directly regard this kind of disturbance signal as pulse or step signal. When the car is running, the tire bumps and deforms due to the uneven road surface, which leads to the vibration of the whole car. At this time, the shock absorber produces vertical displacement, and the ball rolls on the threaded track of the lead screw, which converts the vertical displacement caused by road surface excitation into rotational displacement. At this time, the vehicle-mounted ECU calculates the ideal operating force through the controller, and the motor circuit supplies power to the motor according to the weak signal sent by the processor, so that the motor is in an active rotation state, so that the movement direction of the lead screw is opposite to the vibration direction, and the ball is in a follow-up state during this process.

Active suspension adopts active control mechanism, and the control law calculated by on-board ECU is transmitted to the actuator, so that it can provide driving force to resist road vibration. Energy-regenerative suspension is one of the active suspensions, which has the characteristics of energy recovery besides the related performance of active suspension. The main components of the energy-feeding active suspension structure are spring, suspension dynamic deflection sensor, drive energy storage circuit, main controller, vehicle battery and motor actuator, as shown in Figure 2.

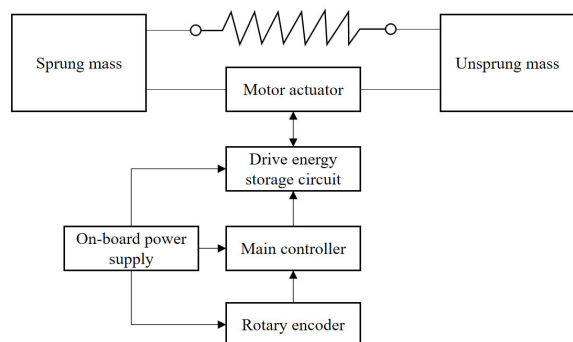

Figure 2 Energy-feeding active suspension structure

When the vehicle runs on uneven road, the energy-feeding suspension converts the linear motion between the sprung mass and the unsprung mass into the rotary motion of the energy-feeding motor, and the energy

conversion device composed of the ball screw mechanism and the rotary motor can recover the vibration energy and deliver it to the battery or capacitor for use in other parts of the automobile. The relative motion of the spring-loaded mass, at this time, the energy feeding mechanism will convert the kinetic energy of this relative motion into electric energy recovery; However, excessive vibration of the car body will make the rider feel uncomfortable, and the ride comfort and handling stability will also be affected. At this time, the controller calculates the required damping force according to the car body state and the pre-designed control algorithm, which is obtained by the current value of the motor control circuit. When the vehicle is running, the road roughness, as the vibration input of the vehicle, will cause the relative motion between the sprung mass and the unsprung mass. At this time, the energy feeding mechanism will convert the kinetic energy of this relative motion into electric energy recovery; However, excessive vibration of the car body will make the occupants feel uncomfortable, and the ride comfort and handling stability will also be affected. At this time, the controller calculates the required damping force according to the state of the car body and the pre-designed control algorithm, and the damping force is obtained by the current value of the motor control circuit.

5. Conclusions

With the growth of automobile industry, people have higher and higher requirements for the ride comfort and handling stability of automobiles. Suspension system is an important part of automobile, and its performance will have a vital impact on the ride comfort and handling stability of automobile. As an important part of automobile suspension, shock absorber has great influence on automobile performance. Due to the energy and environmental crisis, electric vehicles will become the future development trend of the future automobile industry. However, electric vehicles have the problem of short driving range, so how to improve the driving range of electric vehicles is also very important. The actual output control force of the actuator should always be consistent with the ideal active control force calculated by the controller. The direct current controller controls the energy feedback loop to adjust the motor winding current, so that the electromagnetic damping force of the linear motor can track the ideal electromagnetic damping force required by the system, and the motor damping force can be adjusted in real time. The vibration suppression ability and energy recovery ability of electromagnetic suspension system are mutually restricted. In full active mode, the controller can get better ride comfort on the premise of consuming battery energy. In semi-active mode, energy can be recovered to the battery, but the improvement level of ride comfort is reduced.

References

1. Ricciardi V, Ivanov V, Dhaens M, et al. Ride Blending Control for Electric Vehicles[J]. World Electric Vehicle Journal, 2019, 10(2):36.

2. Jiang B, Fitzgerald B. growth of a Rotary Screw Compressor for Electric Truck Air Brake and Suspension System[J]. SAE International Journal of Commercial Vehicles, 2021(3):14.
3. Hu X, Sun J, Chen Y, et al. Considering Well-to-Wheels Analysis in Control Design: Regenerative Suspension Helps to Reduce Greenhouse Gas Emissions from Battery Electric Vehicles[J]. Energies, 2019, 12(13):2594.
4. Urrea C, Garrido F, Kern J. Design and Implementation of Intelligent Agent Training Systems for Virtual Vehicles[J]. Sensors, 2021, 21(2):1-25.
5. Lu Y, Khajepour A, Liu Y, et al. Adaptive cabin suspension systems of commercial vehicles: a review of the state-of-art and future trends[J]. International Journal of Heavy Vehicle Systems (IJHVS), 2022(1):29.
6. Lv X, Ji Y, Zhao H, et al. Research Review of a Vehicle Energy-Regenerative Suspension System[J]. Energies, 2020, 13(2):441.
7. Kazemian A H, Fooladi M, Darijani H. Non-linear control of vehicle's rollover using sliding mode controller for new 8 degrees of freedom suspension model[J]. International Journal of Heavy Vehicle Systems, 2019, 26(5):707.
8. Dubrovskiy A, Aliukov S, Dubrovskiy S, et al. Adaptive suspension of vehicles with new principle of action: Theoretical bases and experimental investigations[J]. Engineering Letters, 2018, 26(4):526-534.
9. Liu Z, Hao H, Cheng X, et al. Critical issues of energy efficient and new energy vehicles development in China[J]. Energy Policy, 2018, 115(4):92-97.
10. Tan R, Lin B. Public perception of new energy vehicles: Evidence from willingness to pay for new energy bus fares in China[J]. Energy Policy, 2019, 130(7):347-354.
11. Hovgard M, Jonsson O, Murgovski N, et al. Cooperative energy management of electrified vehicles on hilly roads[J]. Control Engineering Practice, 2018, 73(4):66-78.
12. Liu Z, Liu X, Hao H, et al. Research on the Critical Issues for Power Battery Reusing of New Energy Vehicles in China[J]. Energies, 2020, 13(8):1932.