

# Analysis of technological and design schemes of machines for applying liquid complex fertilizers

*Alexander Serguntsov\**

Kuban State Agrarian University named after I.T.Trubilin, 350044 Krasnodar, Russia

**Abstract.** Plant additional fertilizing is one of the main operations for plant development, since the degree of its nutrition, and therefore its development, will depend on the correct application of fertilizers (in terms of timing and doses). Liquid ones can be applied using sprayers or a multi-injector. We also propose to introduce a pneumatic system into the design of the disk, namely, into the passage hole of the tooth, which will allow it to be blown after the tooth is found in the soil, contributing to the correct operation of the multi-injector. This design will allow working in the field even on waterlogged soils without violating agrotechnical requirements by eliminating the sticking of the hole on the needle of the multi-injector disk.

## 1 Materials and methods of research

Obtaining high and stable yields of agricultural crops is impossible without the use of fertilizers and agrochemicals. A significant effect is provided by the use of liquid complex fertilizers (LCF), even in comparison with granular ones. However, the lack of production of modern machines for the introduction of housing and communal services and the deterioration of the existing fleet hinders the use of technologies for the introduction of housing and communal services. Existing machines for the LCF application of work according to the general principle – the preparation of the working solution is carried out in a common tank with constant stirring to maintain a given concentration of fertilizers, with such a technology of preparation of the working solution, it is impossible to regulate the concentration of fertilizers during the operation of the machine, the problem is solved by combining the operations of dosing, preparation and supply of the solution of LCF. This method of preparing the solution minimizes the deposition of fertilizers, and is also effective when applying biological products to the soil, by reducing the mechanical effect on microorganisms contained in biological products, when they are applied, the duration of the mechanical effect on the solution with biological products plays a role, as well as when they are introduced into the soil, the holes in the needles on disk multi-injectors are often clogged, which disrupts the feeding process [1, 7-9].

---

\* Corresponding author: [sasha2008\\_9191@mail.ru](mailto:sasha2008_9191@mail.ru)

## 2 Results of research

The difference in the types of liquids used and the variety of ways of applying liquid fertilizers causes a large number of different machine designs. Local application of liquid fertilizers is carried out in three ways: the first - application in furrows; the second - application in wells; the third - mixed. The second method of application is commonly called focal. Currently, the first method has become the most widespread, due to its simplicity. To implement this method, standard feeding knives for granular tuks are used, it is also possible to use fumigators, plows, plane cutters adapted for the introduction of LCF, presented in Figure 1 [4, 5].

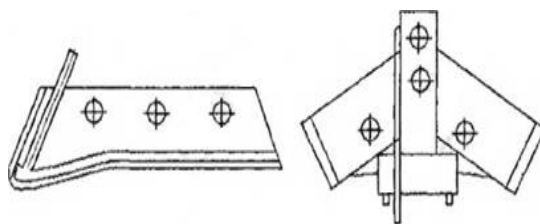

**Fig. 1.** Scheme of conversion of a ploughshare and a planar cutter for applying liquid fertilizers

The designs of specially created feeding knives presented in Figure 2 differ in a wide variety.

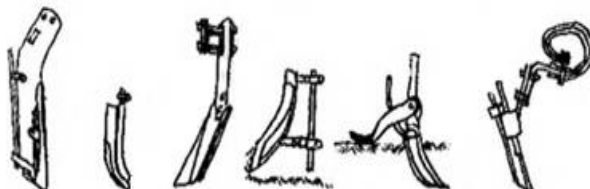

**Fig. 2.** Schemes of designs of feeding knives

Such working bodies are used mainly when applying liquid fertilizers for row crops. At the same time, they are installed on the transverse beam of the machine in one, two or three rows in an amount from 2 to 15 pieces. For this purpose, a frame cultivator KRN-4,2 is used. Abroad, special machines are made for the same purposes, consisting of a trailer or hinged frame, a container for fertilizers, transverse bars with loosening working bodies. At the same time, machines designed for row crops can have up to 40 working bodies and a gripping width of up to 25 m, shown in Figure 3 [2, 6].

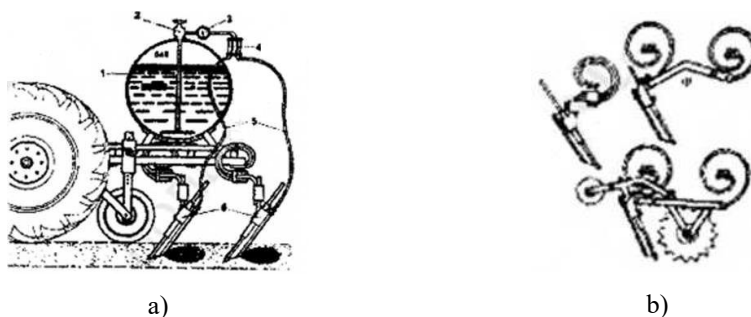

a, b – unit with cuttings knives "GLI" (Italy)

**Fig. 3.** Machines for furrowing intra-soil application of liquid fertilizers

However, such machines have serious drawbacks that do not allow them to be used effectively for applying liquid fertilizers for perennial plantings. Such a disadvantage is significant damage to the root system during the passage of coulters at a depth of more than 20 cm, as required by agricultural technology.

The use of working bodies for the focal application of liquid fertilizers will avoid this disadvantage. Let us further consider the design schemes of machines and working bodies for such an introduction [3, 5].

The beginning of their serious developments can be considered 1938, when K.P. Magnitsky proposed an injection method for introducing nutrient solutions into the soil. Then N.D. Kholin and G.L. Shendrikov in 1953 proposed a method for applying liquid fertilizers using manual hydraulic drills. A set of manual hydraulic drills of the GB 35/25 brand presented in Figure 4 was mass-produced, but one worker could make only 800 per shift...1000 holes, and large labor costs were required to fertilize one hectare.

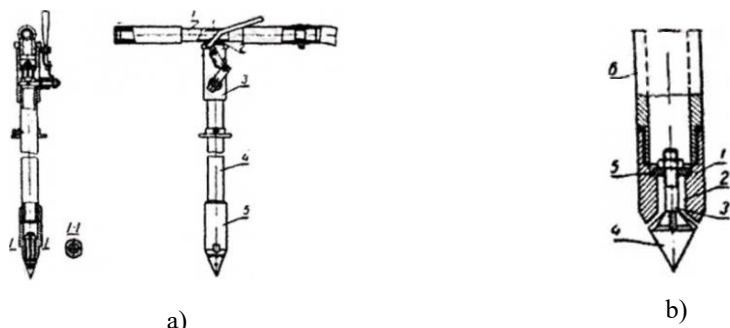

a) – general view: 1 – handle; 2 – fitting; 3 – lever valve; 4 – barrel; 5 – tip; b) – hydraulic drill tip diagram: 1 – tube; 2 – channel; 3 – stem; 4 – discharge valve; 5 – shut-off valve; 6 – barrel

**Fig. 4.** Hydraulic drill GB 35/25

Subsequently, a mechanized hydraulic drilling unit APV-10-2 was created, shown in Figure 5, in which ten hydraulic drills are assembled on one frame consisting of two transverse bars and two longitudinal water distribution pipes.

Under the action of hydraulic cylinders, the frame is lowered, sinking the needles, the liquid to which is supplied by a vortex pump from a trailer tank. The depth of the pits reaches 70 cm, the diameter of the hole is 6 cm. A similar unit was created for gardens by the institute "Projectgidromechanization".

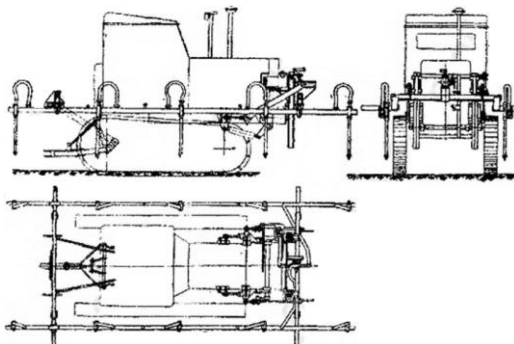

**Fig. 5.** The unit of mechanical hydraulic drills ALV-10-2.

The pressure intra-soil feeder NVP-1 is designed for root fertilization of fruit trees shown in Figure 6.



**Fig. 6.** Pressure intra-soil feeder NVP-1

The hydraulic drilling manifold, made in the form of a half-ring, was mounted on an E-153A excavator. The second variant of the NVP-2 feeder, shown in Figure 7, had two hydraulic drill collectors for feeding two rows at the same time and, consequently, higher productivity.

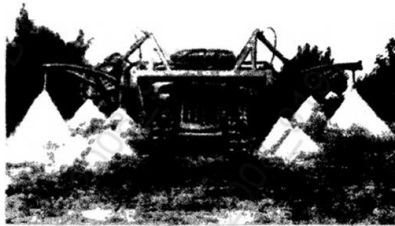

**Fig. 7.** NVP-2 machine for applying liquid fertilizers in gardens

The injection depth of these machines was also 70 cm.

The advantages of the machines described above include:

a) vertical entry of the needle into the soil, so that the size of the hole and the evaporation of fertilizers will be minimal;

b) sufficient depth of liquid application.

The main disadvantage of such machines is the frequency of action and, as a result, low productivity. In addition, the technological process of such machines requires a certain accuracy of maneuvering the tractor and the work of a tractor driver on such units is very stressful.

To increase the productivity of machines with vertically entering needles, the Moldovan NIISVIV together with the Chisinau GSKB for machines for mechanization of work in gardens and vineyards in 1963 developed a FDL machine (deep liquid fertilizer) presented in Figure 8.

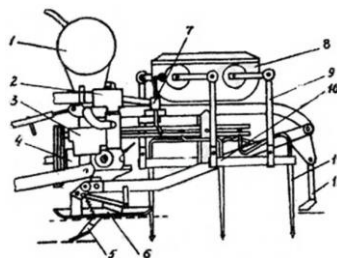

1 – reservoir; 2 – filter; 3 – pump; 4 – conical reducer; 5 – furrow openers; 6 – support slide; 7 – valve dispenser; 8 – reducer; 9 – parallelogram mechanism; 10 – cross beam; 11 – needles; 12 – spools

**Fig. 8.** A machine for applying fertilizer solutions of FDL

The possibility of simultaneous penetration of needles and continuous movement of the machine was carried out by a parallelogram mechanism. However, this did not give a tangible advantage in the speed of movement of the unit and the performance of the FDL machine remained low at 1.12 ha per shift.

For this consideration, the unit designed by B.P. Rytsev in the state farm "Yuzhny" of Krasnodar Territory for the introduction of nutrient solutions into the soil under the name "Yuzhanka" is of interest. From the diagram of the unit shown in Figure 9, it can be seen that the needles of this machine also vertically enter the soil. They are located on extendable rods in the corners of two tetrahedral frames located on the left and right in front of the tractor and connected by a shaft. When the car is moving, the frame is rolling. Liquid is supplied to the needles by a pump from a trailer tank.

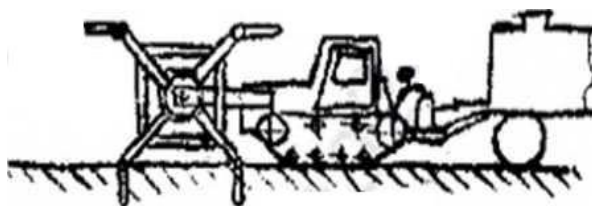

**Fig. 9.** The scheme of the machine "Yuzhanka"

Further improvement of agricultural machinery followed the path of creating high-speed, and therefore more productive equipment. The design features of the liquid fertilizer machines discussed below allow them to increase significantly operating speeds in comparison with hydraulic drilling units.

According to the principle of operation of the working bodies, these machines can be divided into hydraulic and rotary.

Currently, different types of machines are used for applying liquid fertilizers, both for deep and surface, these machines are shown in Figure 10.



a)



b)



c)

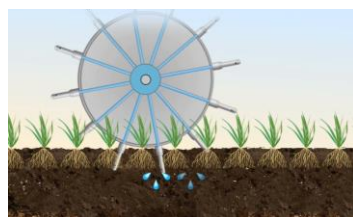

d)



e)

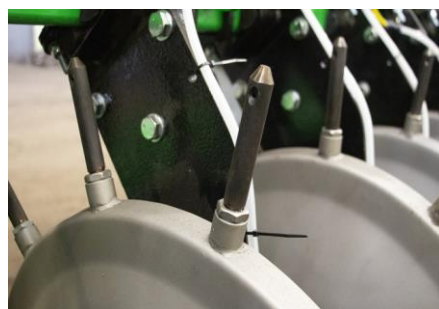

f)



g)



h)

a – chisel plow ("Truzhennik" GRS-4) with a CAS application system; b – cultivator-feeder mounted disk KPND-9.70; c – unit for intra-soil application of APVU-9; d – working body of the APVU-9 unit; e – unit for injection application of liquid fertilizers mounted Vulkan 12 VELES AGRO; f – the working body of the Vulkan 12 VELES AGRO unit; g – the multi-injector Tuman-2; h - the working body of the Tuman-2 unit

**Fig. 10.** Modern machines for intra-soil application of liquid fertilizers

It can be seen from Figure 10 that the most commonly used units have a disk working organ with needles through holes in which liquid fertilizers are fed into the soil.

### 3 Conclusion

The advantages of liquid fertilizer injection technology are high efficiency of application in any climatic zones, including arid ones, fertilizer injections made by a disk working body require less than 5% of the volume of moisture in the upper layer of the soil. Relatively small plant roots absorb ammonium, regardless of the water content in the soil. Liquid fertilizers do not need additional moisture to dissolve, so after application they are immediately available to the plant. A more uniform application and precisely dosed distribution over the area occurs. Thanks to rubber shock absorbers, injection wheels repeat the relief of the field, so fertilizers penetrate evenly on each section of the field.

### References

1. Serguntsov, A. Harrowing of sowings with synchronous additional fertilizing / A. Serguntsov, N. Malashikhin // MATEC Web of Conferences : 2018 International Conference on Modern Trends in Manufacturing Technologies and Equipment, ICMTMTE 2018, Sevastopol, 10–14 September 2018. Vol.224. – Sevastopol: EDP Sciences, 2018. – P. 05016. – DOI 10.1051/mateconf/201822405016.

2. Serguntsov, A. Optimization of parameters and operating modes of the rotary working body for harrowing agricultural crops / A. Serguntsov, V. Serguntsova // E3S Web of Conferences, Sevastopol, 07–11 September 2020. – Sevastopol, 2020. – P. 01021. – DOI 10.1051/e3sconf/202019301021.
3. Serguntsov, A. Operational parameters and modes of rotary working body for harrowing crops / A. Serguntsov, N. Malashikhin, V. Serguntsova // E3S Web of Conferences, Sevastopol, 09–13 September 2019. Vol.126. – Sevastopol: EDP Sciences, 2019. – P. 00023. – DOI 10.1051/e3sconf/201912600023.
4. Verkhovsky V.M. Investigation of the process of intra-soil application of liquid fertilizers and justification of the parameters of the hydromechanical working body. Thesis of PhD in Engineering. M., 1982, 36 p.
5. Verkhovsky V.M., Litvinov M.A., Mikheev V.V. Soil resistance to immersion of a hydromechanical working organ. Zh. Mechanization and electrification of social sciences, 1976, No. 10, pp. 40-41
6. Kainson A.Ya. Investigation of the intra-soil distribution of fluid for the creation of hydraulic drilling machines. Tr. VNIIGiM, 1968, issue 4, pp. 377-384
7. Mechanization of intra-soil nutrition of agricultural crops. M.: Kolos, 1970, 71 p.
8. A.A.W. Chestney. Fertilizer solution spreder. Journal of agricultural engineering, 1966, p. 307-309
9. Bill Zipf Flo-lizer and the big A. Fertilizer solution. 1966, №10(4), p. 26-28.