

# IoT-Powered UPS Battery Monitoring: Ensuring High availability and reliability for Critical Systems

Chandra Prasath S<sup>1</sup>, Darwin N<sup>1</sup>, Ramkumar R S<sup>1</sup>, Nithishkumar S<sup>1</sup>, Somasundharam P L<sup>2\*</sup>

<sup>1</sup> Electronics and Instrumentation Engineering, M.Kumarasamy College of Engineering, Karur, India

<sup>2</sup> Electrical and Electronics Engineering, M.Kumarasamy College of Engineering, Karur, India

**Abstract.** An Uninterrupted Power Supply (UPS) is a critical component in any high availability system. However, the effectiveness of a UPS depends largely on its battery backup, which must be continuously monitored to ensure that it is working properly. In the past, this monitoring has been done manually or through local monitoring systems, but advances in IoT technology now make it possible to remotely monitor the status of UPS batteries and receive real-time alerts if any issues arise. The proposed system will have several benefits over existing battery monitoring systems. First, it will be fully automated, reducing the need for manual monitoring and minimizing the risk of human error. Second, it will be accessible remotely, allowing system administrators to monitor the status of the battery backup system from anywhere in the world. Finally, the system will be scalable, allowing additional sensors to be added to the network as needed. Nevertheless, physically checking the UPS battery is highly challenging since it requires more money and time. Data center operators, at the centre of the digital economy, are under pressure from several directions. sustaining the highest level of availability at the most affordable level. A leading provider of battery management solutions.

## 1 INTRODUCTION

In today's digital world, high availability systems are critical to the smooth functioning of various organizations, including data centers, hospitals, financial institutions, and many more. These systems require a continuous power supply, and to achieve that, they rely heavily on uninterrupted power supplies (UPS). A UPS provides power backup during power outages and prevents downtime, which is crucial for high availability systems. However, a UPS is only as effective as its battery backup, which must be continuously monitored to ensure its proper functioning. In the past, UPS battery monitoring was done manually or through local monitoring systems. However, advances in IoT technology have made it possible to monitor UPS batteries remotely, enabling real-time monitoring and alerts. The proposed project aims to develop an IoT-based monitoring system for UPS batteries, specifically for high availability systems. This system will consist of a network of sensors placed in strategic locations throughout the battery backup system [1]. These sensors will collect data on critical performance indicators, such as voltage, current, temperature, and battery capacity. The collected data will be transmitted wirelessly to a central monitoring system accessible via the internet. The monitoring system will use data analytics and machine learning algorithms to analyze the data and detect any potential issues with the battery backup system. If any issue is detected, the system will generate real-time alerts, allowing system administrators to take prompt action and prevent downtime. The proposed system will have several advantages over existing battery monitoring systems. It will be fully automated, reducing the need for manual monitoring and minimizing the risk of human error. It will be remotely accessible, enabling system administrators to monitor the status of the battery backup system from anywhere in the world. Finally, the system will be scalable, allowing additional sensors to be added to the network as needed [2].

## 2 LITERATURE SURVEY

Here is described a different approach to the methods now in use for classifying batteries based on their chemistry. Battery testing equipment was used to age batteries with four distinct chemical compositions. The creation of a 'UPS battery management system' is discussed in this paper. This device assists in determining the status of batteries backing hours for both running and stationary modes by using an ATMEGA controller [3]. The BMS provides the analysis of SoC (State of Charging), DoD (Depth of Discharge) State of Health (SoH), battery life, and (Battery Management System). The battery's voltage and current are measured using the sensor and a 12 Volt sealed valve-controlled lead

---

\* Corresponding author: [somasundarampl.eee@mkce.ac.in](mailto:somasundarampl.eee@mkce.ac.in)

acid battery [4]. This study shows how the Internet of Things (IoT) can be used to monitor an electric vehicle's battery performance. It should go without saying that an electric car's battery serves as its primary energy source. Unfortunately, the vehicle's energy supply is steadily reducing, which results in performance decline. The manufacturing of batteries is quite concerned about this. This paper uses an Arduino board to demonstrate the design of a battery voltage sensor for a UPS (uninterruptible power supply). The battery sensor gauges the external battery voltage and contrasts it with the uninterruptible power supplies dc charging voltage. If there is a significant difference between the two voltages, an alarm is meant to notify the employees [5]. The majority of the time, UPSs lack sufficient sensors to safeguard the battery circuit and instead have sensors primarily designed to protect the rectifier and inverter circuits. Hydrogen and oxygen are released when lead acid batteries used in electrical substations are charged. If these gases are not adequately vented, they might be hazardous and pose a fire risk. Thus, the creation and installation of a network control panel for an HVACS is the aim of this study. To accomplish a cost-effective design, this is done by using a specialised set of controllers that includes more than thirty loops of proportional, integral, and derivative control [6]. The development of electric vehicles advanced the car industry globally. It contributes significantly to maintaining a clean environment. The battery for an electric vehicle is one of the key parts, thus it has been preserved for a longer lifespan. In order to increase the battery's longevity, metrics like voltage and SoC (Status of Charge) are therefore gathered and monitored. The battery's performance is also greatly influenced by the temperature. Monitoring systems play a crucial role in assuring the dependability and stability of power production systems, including those that use sustainable and renewable resources [7]. For the purpose of monitoring and evaluating the performance of PV installations, For the Saharan region's renewable energy research unit (URERMS) Adrar, a The creation of PV uninterruptible power supply. To maximize the power from the PV panels, the PVUPS includes a desktop PC UPS that is powered by the MPPT charge controller [8]. Modern battery powered applications, including electric cars, portable electronics, and storage for renewable energy sources, all benefit from battery management systems. Also, it improves the efficiency, condition, and life of the battery. This study focuses on tracking the battery's level of charge, temperature, and current for solar panels with batteries attached for residential use [9]. ESSs need a BMS algorithm that can control the status of the battery since ageing raises a battery's internal resistance and decreases its capacity. In order to control battery status, this research suggests a method for calculating battery efficiency. The suggested method for calculating battery efficiency makes use of the battery capacity, charging duration, and charging current. The suggested SoC and SoH calculations are used to a proposed algorithm that can reliably detect the battery condition [10]. Operating an electrical system requires a secure BMS. This research examines the specifics of BMS for stationary energy storage and electric vehicles. The examination covers a variety of BMS-related topics, such as testing, component functionality, 'topology', 'operation', 'architecture', and BMS safety issues. A evaluation of existing BMS-related standards and norms is also conducted.

### 3 PROPOSED METHOD

Proposed UPS battery monitoring system over IoT for high availability systems will consist of the following components: Sensors: The system will use a network of sensors placed in strategic locations throughout the battery backup system. These sensors will collect data on critical performance indicators, such as voltage, current, temperature, and battery capacity [11]. IoT Gateway: The sensors will transmit data wirelessly to an IoT gateway, which will collect and analyze the data. Also, the gateway will link the system to the internet, enabling remote access to the surveillance system. Data analytics and machine learning techniques will be used by the central monitoring system to assess the information gathered from the sensors. System will monitor the status of the battery backup system in real-time and generate alerts if any potential issues are detected. The monitoring system will have a user-friendly interface that allows system administrators to view the status of the battery backup system remotely [12]. The interface will provide real-time data on the performance of the UPS batteries, allowing administrators to take prompt action if necessary. Alert System: The monitoring system will generate alerts if any potential issues are detected with the battery backup system. The proposed system will have several advantages over existing battery monitoring systems. It will be fully automated, reducing the need for manual monitoring and minimizing the risk of human error. It will be remotely accessible, enabling system administrators to monitor the status of the battery backup system from anywhere in the world. Finally, the system will be scalable, allowing additional sensors to be added to the network as needed [13-14].

### 4 SOFTWARE DESCRIPTION

Microcontroller programming makes extensive use of the C and C++ programming languages. In addition to employing standard compiler toolchains, the Arduino project includes an IDE (integrated programming environment) based on the Processing language project. The Interaction Design Institute Ivrea in Ivrea, Italy, hosted a course in 2005 that served as the basis for the Arduino project. Its objective was to offer both professionals and novices a straightforward and cost-effective way to construct gadgets that use sensors and actuators to communicate with their environment. Common examples of the kind of technology targeted at immigrants include simple robots, motion detectors, and thermostats. Any language that can generate binary machine code for the intended processor can be used to create an Arduino application. One of the two development environments that Atmel provides for its microcontrollers is modern Atmel Studio. The Arduino project provides a Java-based, cross-platform programme called Arduino IDE (integrated



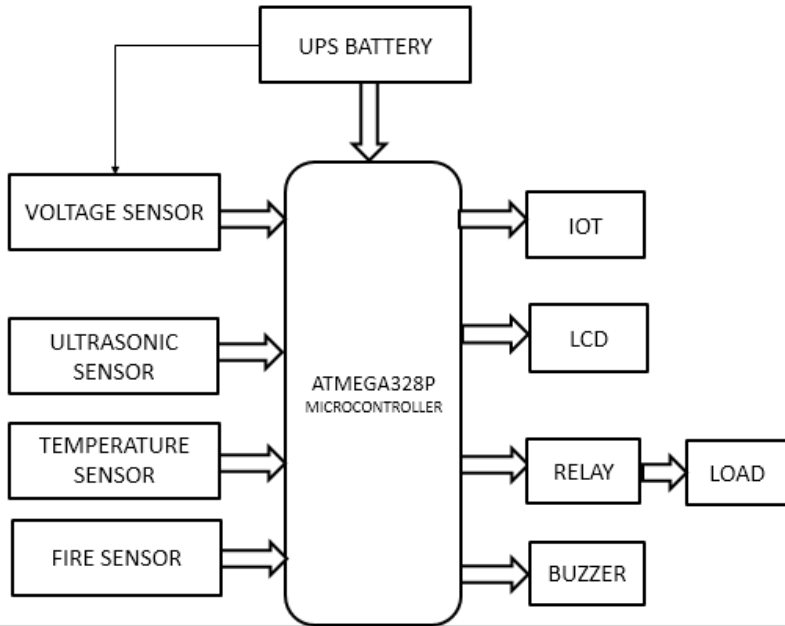

Fig. 3. Hardware Implementation

## 4.2 HARDWARE EXPLANATION

It is proposed to use an IOT-based battery management system for UPS. This system includes a voltage sensor that detects voltage and updates the IOT in Fig.3. A buzzer alert is delivered and shown on the LCD if the temperature of the battery increases, which is detected by the temperature sensor. To ensure safety, the system is linked to a fire sensor, which detects fire and issues an alarm. The acid level of the UPS battery is detected using an ultrasonic sensor. If any changes or uncertainties occur, such as a rise in temperature, a fire in the battery, or an increase in acid level, the load will be shut off immediately. The observed parameters are automatically updated in IOT for remote monitoring and presented on the LCD display.

## 5 METHODS

### Module List

- ATMEGA328P MICROCONTROLLER
- BATTERY
- VOLTAGE SENSOR
- TEMPERATURE SENSOR
- ULTRASONIC SENSOR
- FIRE SENSOR
- NODEMCU
- RELAY
- LCD
- BUZZER

### 5.1 MODULE DESCRIPTION

#### 5.1.1 Power Supply

Power supplies are devices or systems that supply electrical power to other devices or systems. It ensures that the system receives the proper amount and type of electrical power to function properly, making it a crucial part of any electrical or electronic system. A power supply can switch the electrical power's kind, such as from high voltage to low voltage or from AC (alternating current) to DC (direct current). Controlling power supplies, battery backup power

supply units, and uninterruptible power supplies are just a few examples of the many different types of power supplies available, each with its own specific features and benefits (UPS) in Fig.4.



**Fig. 4.** Atmega328p Microcontroller

The mega AVR family of microcontrollers includes the single-chip ATmega328, which was developed by Atmel. It features an 8-bit RISC CPU unit with a modified Harvard design. The 8-bit AVR-based microcontroller from Atmel includes a 6-channel, 10-bit A/D converter, 8 channels in TQFP and QFN/MLF packages, a programmable watchdog timer, 1 KB of EEPROM, 2 KB of SRAM, 23 general-purpose I/O lines, 32 general-purpose working registers, and 3 flexible timer/counters with compare modes. The device can function between 1.8 and 5.5V. The throughput of the gadget is extremely close to 1 MHz. When being sent to the MCU and when being received from the MCU, serial data is timed on the rising edge and the falling edge, respectively. When RESET and SCK are both set to 0, electricity is supplied to VCC. At least 20 milliseconds must pass before the programming allows the serial instruction "0xAC, 0x53, 0x00, 0x00." to be executed.

### 5.1.2 battery

Lead acid battery chargers typically do two things. Restocking capacity comes first, usually as soon as it is practical. The second is capacity preservation by compensating for self discharge. For the optimal performance in both cases, lead sulphate is converted into lead on the battery's negative plate and lead dioxide on the positive plate. Once the majority of the lead sulphate has been converted, over-charge reactions start, and they typically produce hydrogen and oxygen gas. The electrons that go from a terminal marked "negative" to a terminal marked "positive" are generated by an external electric circuit. Redox processes transform high energy reactants into lower energy products when a battery is coupled to an external electric load and the free energy difference is supplied into the external circuit as electrical energy. A "battery" used to be a device made up of several cells, however currently, devices made up of a single cell also come into this category in Fig.5.



**Fig. 5.** Battery

### 5.1.3 Voltage sensor

A voltage sensor is a sensor that measures and records the voltage level of an object. Voltage sensors are capable of measuring both AC and DC voltage levels. In addition to taking voltage as an input, the sensor can also produce switches, analogue voltage signals, current signals, or aural signals. Sensors are tools with the ability to detect and respond to specific electrical or optical signals. Traditional current and voltage measuring methods have been effectively replaced by the use of current sensor and voltage sensor approaches. details on the voltage sensor. The supply of voltage may be found out about, watched over, and measured using a voltage sensor. It has the ability to measure voltage levels at both AC and DC levels. The voltage sensor receives voltage as its input, and it can provide

outputs in the form of analogue voltage signals, switches, aural signals, analogue current levels, frequencies, or even outputs that are frequency modulated. To put it another way, certain voltage sensors can produce sine waves or pulse trains, but others can provide outputs that are modulated in terms of amplitude, pulse width, or frequency. Voltage dividers serve as the foundation for the measurement in voltage sensors. The two most common types of voltage sensors are resistive type voltage sensors and capacitive type voltage sensors in Fig.6.



**Fig. 6.** Voltage sensor

## 6 RESULTS

This picture explain to the voltage sensor is a component of this system that monitors voltage and updates the IOT. A buzzer alert is delivered and shown on the LCD if the temperature of the battery increases, which is detected by the temperature sensor. This illustration shows a voltage sensor, which is a component of this system that monitors voltage and updates the IOT in Fig.7.

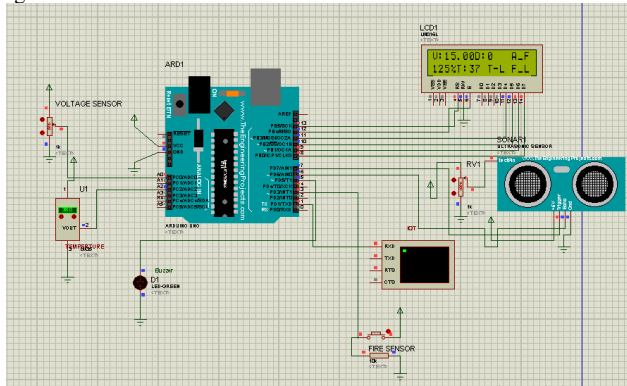

**Fig. 7.** Simulated output

The system is connected to a fire sensor, which detects fire and sounds an alert to protect safety. Using an ultrasonic sensor, the UPS battery's acid level is determined. The load will be quickly turned off if any alterations or unpredictabilities take place, such as an increase in temperature, a battery fire, or a rise in acid level. For remote monitoring, the observed parameters are instantly updated in IOT and shown on the LCD screen. If any the sensors value are normal so the output Of the LED is OFF.

If the temperatures of the battery rises and is detected by the temperature sensor, a buzzer alarm is sent and shown on the LCD. To ensure safety, the system is linked to a fire sensor, which detects fire and sounds a warning. The acid level of the UPS battery is detected using an ultrasonic sensor. If there are any changes or unpredictabilities, such as an increase in temperature, a battery fire, or a rise in acid level, the load will be instantly shut off. The detected parameters are promptly updated in IOT and shown on the LCD panel for remote monitoring. If any the sensors value are normal so the output Of the LED is OFF.

## 7 Conclusion

In conclusion, implementing an IoT-based UPS battery monitoring system for high availability systems can bring several benefits. By continuously monitoring the UPS battery status and sending real-time alerts, this system can help prevent unexpected downtime and minimize the risk of data loss or damage to critical systems. The use of IoT technology allows for remote monitoring and management, making it easier for IT administrators to access critical information and take necessary actions. This can save time and reduce the need for on-site maintenance, which can be especially important in large-scale data centers or other mission-critical environments.

In order to ensure battery performance degradation, the study focused on the design and implementation of an IOT based UPS battery monitoring system. We are building a system with an IOT model for UPS battery management by regulating critical factors like voltage and temperature. It is critical that the BMS is carefully maintained in terms of battery reliability and safety. This research examines the 'Battery Management System' and improves UPS power performances. Furthermore, implementing 'battery management system' can help in significantly reduce greenhouse gas emissions.

#### ADVANTAGES

- Real-time monitoring
- Remote management
- Predictive maintenance
- Customizable alerts
- Improved efficiency

#### APPLICATIONS

- Data centers
- Healthcare
- Banking and finance
- Manufacturing Retail

## 8 FUTURE WORKS

- Machine learning & Artificial intelligence: The combination of Artificial intelligence and Machine learning technologies can enhance the capabilities of UPS battery monitoring systems. These technologies can enable the system to learn from historical data, identify patterns, and provide more accurate predictions and insights into battery performance.
- Integration with other systems: An IoT-based UPS battery monitoring system can be integrated with other critical systems, such as HVAC and lighting systems, to provide a more comprehensive view of overall facility performance. This can help optimize energy consumption and improve overall efficiency. Increased automation: By incorporating automation capabilities, an IoT-based UPS battery monitoring system can streamline maintenance and repairs. For example, the system could automatically schedule maintenance or replacement when necessary, reducing the need for human intervention.
- Predictive maintenance: Thermal imaging and vibration analysis are two predictive maintenance methods that may be used to find possible problems before they arise. By detecting anomalies in battery performance, an IoT-based system can alert IT administrators to potential problems and enable proactive maintenance.
- Energy storage optimization: The integration of energy storage systems with UPS battery monitoring systems can help optimize energy usage and reduce costs. By storing excess energy during off-peak hours, energy can be used during peak demand periods, reducing reliance on the grid and lowering costs.

## References

1. M. Karupphasampandian, V. Agnes Idhaya Selvi, Paramathma, and M. Krishna. 2021 International Conference on Advancing Computing and Innovative Technologies in Engineering, "Development of Web Server Based Battery Management System for UPS" (ICACITE). IEEE, (2021).
2. Battery Checking framework Based on PLC, Worldwide Diary of Science and Exploration, D. S. Suresh, Sekar R, and Mohamed Shafiulla, **3**, 6 (2012).
3. Sardar, H. Naseer, E. Qazi, and W. Ali, "Shrewd Networks Wide Region Checking Framework for UPS Batteries Via GSM," in Towards a Better Pakistan: Second Global Multidisciplinary Conference, **1** (2012).
4. Selvabharathi, D., & Muruganatham, N. Utilizing a Feed-Forward Neural Network to Predict Lead-Acid Battery Health. Journal of Circuits, Systems and Computers, **31**, 5 (2022).
5. C Bhuvaneshwari, A Manjunathan, "Reimbursement of sensor nodes and path optimization", Materials Today: Proceedings, **45** (2021).
6. Wang Z-H, Hendrick, Horng G-J, Wu H-T, Jong G-J. A prediction method for voltage and lifetime of lead-acid battery by using machine learning. Energy Exploration & Exploitation, **38**, 1 (2020).
7. Kumar T.V, Mathankumar M, Manjunathan A, Sathiyaraj J," Time based costing of energy storage system with optimal scheduling and dispatch under demand" Materials Today: Proceedings, **45** (2021).
8. CH Liu and MT Tsai "Design and implementation of a cost-effective quasi line-interactive UPS with innovative topology", IEEE Transactions on Power Electronics, **18**, 4 (2003).
9. K Balachander, G Suresh Kumar, M Mathankumar, A Manjunathan, S Chinnapparaj, "Optimization in design of hybrid electric power network using HOMER", Materials Today: Proceedings, **45** (2021).

10. C Ambika Bhuvaneswari, ED Kanmani Ruby, A Manjunathan, R Balamurugan, P Jenopaul, Belachew Zegale Tizazu, Effects of Novel Material Field Effect Transistor for Heterogeneous Energy and Traffic-Aware Secure Applications”, *Advances in Materials Science and Engineering*, Article ID 9085854 (2021).
11. O. A. Mohamad, R. T. Hameed, and N. Täapus, *Design and implementation of real-time tracking system based on Arduino Intel Galileo*, 8th International Conference on Electronics, Computers, and Artificial Intelligence (ECAI), 30 June 2016 - 02 July 2016, Ploiesti, Romania (2016).
12. Yong Tian, Dong Li, Jindong Tian, *An optimal nonlinear observer for state-of-charge estimation of lithium-ion batteries*, Industrial Electronics and Applications (ICIEA), 12th IEEE Conference 18-20 June 2017, Siem Reap, Cambodia (2017).
13. G Gabriel Santhosh Kumar, A Manjunathan, T Sathesh Kumar, M Mathankumar, G Anushree, N Mohanasundaram, *Analysis on the Impacts of Light Emitting Diodes in Power System using FLUKE 430-II D Power Quality Analyser*, International Conference on Advancements in Electrical, Electronics, Communication, Computing and Automation (ICAECA), IEEE, 08-09 October 2021, Coimbatore, India (2021)
14. Kannadhasan Suriyan, Nagarajan Ramalingam, Kanagaraj Venusamy, Sathish Sivaraman, Kiruthiga Balasubramanian, Manjunathan Alagarsamy, *Bulletin of Electrical Engineering and Informatics*, **11**, 2 (2022).