

Study on computerized measurement-control system for determining the condition of electrical network insulation and permitted connections for electrical energy consumption

Narzullo Mirzoyev¹

¹Energoadit Department, Bukhara Institute of Engineering and Technology, Bukhara, Uzbekistan

Abstract. In this article electrical distribution in order to ensure the reliability and safe operation of networks, information is provided about the computerized measurement control system that allows determining the state of their insulation. In the article, the functional scheme of the computerized measurement and control system, which allows to determine the state of electrical network insulation and unauthorized connections to electricity, the structural diagram of the connection of the computerized measurement and control device to the electrical network, the structural diagram of the program developed for calculating the electrical network sizes, and the development of mathematical models developed.

1. Introduction

Energy is one of the most important sectors directly related to the country's economy. Therefore, the novelty of the decisions taken on the development of this industry is a realized need, as a result of which it will be possible to raise the quality of the energy sector of Uzbekistan to a new, modern level.

In recent years, a number of laws and decisions have been introduced in the Republic of Uzbekistan to save energy and improve energy efficiency. In the last two years, laws and efficiency decisions "On the use of renewable energy sources" and "On rational use of energy" have been developed in our Republic. The main purpose of these laws and decisions is to increase energy efficiency in the Republic and increase the use of alternative energy sources. In particular, the Resolution "On rapid measures to increase the energy efficiency of economic sectors and the social sphere, introduce energy-saving technologies and develop renewable energy sources" in the Republic of Uzbekistan, a republican commission on the issues of "Development of energy efficiency and renewable energy sources" was established in order to ensure its implementation. By determining the consumption of fuel and energy resources in industrial enterprises and developing energy saving measures on the basis of the statement No. 39 of the Republican Commission of August 18.2020 "Procedure on regulating the consumption of fuel and energy resources in the sectors of the economy of the Republic of Uzbekistan" Tasks were given to determine the consumption of progressive fuel energy resources [1-5]. To fulfill these tasks, it is necessary to create an energy monitoring system in industrial enterprises. In the implementation of the above tasks, industrial enterprises have technical and software problems. For example, there are no devices and software that detect hidden connections to electricity in district power networks. Monitoring of the electricity received from the meters only determines the status after the meter. There is no energy monitoring system in the pre-meter state. Nowadays, any enterprise has a personal computer and Internet networks. By effectively using these opportunities, any industrial enterprise has the opportunity to find a solution to these issues by introducing smart energy monitoring systems. There is no energy monitoring system in the pre-meter state. Nowadays, any enterprise has a personal computer and Internet networks. By effectively using these opportunities, any industrial enterprise has the opportunity to find a solution to these issues by introducing intelligent energy monitoring systems. There is no energy monitoring system in the pre-meter state. Nowadays, any enterprise has a personal computer and Internet networks. By effectively using these opportunities, any industrial enterprise has the opportunity to find a solution to these issues by introducing intelligent energy monitoring systems [5-8].

Currently, energy consuming systems distributed over a large area are of great interest. Most consumers are located far from the control center, which makes them difficult to monitor and manage. These systems include distribution networks, which are the main components in the generation, transmission and distribution of electricity. For the stable

and efficient operation of such networks, on the one hand, it is necessary to monitor and reliably manage the condition of distribution power networks, on the other hand, it is necessary to strictly consider energy resources, as well as ensure electrical safety. To solve these problems, it is necessary to create new information measurement systems, the level and quality of which are clearly insufficient in the systems under consideration [4-5]:

- a) there is no information about individual consumers in real time - whether they are turned on or not, what is their current load, there is no information about their technical condition;
- b) operational balances of supplied and consumed electricity are not available, as balances are drawn up with a long delay based on information provided by consumers in payment receipts;
- c) no diagnostics to determine damage locations and amount of lost electricity.

This problem is most acute in distribution networks that deliver directly to consumers.

The solution to the problem is to create a single computerized information-measurement system that combines the functions of monitoring isolation, accounting for unauthorized consumption of electricity and monitoring network operation modes, using current monitoring devices, dispatching control and electricity measurement.

2. Materials and Methods

Electricity distribution the reliability and safety of networks is mainly determined by the state of isolation of these networks. One of the ways to keep the insulation at the right level is its constant monitoring, which eliminates the occurrence of voltage in non-conducting metal parts, preventing an emergency accident. [10-15].

An analysis of emergency situations in the electrical network shows that about 60% of all power supply interruptions and related interruptions are associated with a decrease in the level of insulation resistance, which ultimately leads to its failure. In this regard, monitoring of the insulation condition in electrical distribution networks has always been and will be very relevant.

We consider insulation control for all active power and reactive power consumers.

A brief description of the technical requirements that must be met during the operation of electric distribution networks is as follows.

Assessment of the level of pollution from industrial enterprises is carried out using the pollution factor. The insulator breakdown current distance of insulators made of glass and porcelain and insulating structures is determined as follows:

$$L = \lambda_e \cdot U \cdot k, \text{ cm}$$

λ_e - the effective length of the current flow, cm/kV;

SHE IS- phase voltage, kV,

K-current utilization coefficient of length.

The specific length of the piercing current distance of the hinged and hanging insulator on metal and reinforced concrete supports should be taken from Table 1 depending on the degree of pollution [16-20].

Table 1. Insulator breakdown current distance

Pollution degree	Special effective displacement distance insulators, cm/kV
Firstly	1,980
Second	2,355
Third	3,000
The fourth	3,500

At an altitude of more than 1000 m above sea level, the effective length of air lines and suspension insulators is from 2000 to 3000 - 10% compared to the standard in Table 1; from 3000 to 4000 m - should be increased by 15%: In the electrical distribution network in question, the length of the path of the distance of the insulator piercing current $L=1*3*1000/220=13,6364$ cm will be.

Currently, uninsulated conductors are protected by self-distance. It is advisable to replace these wires with insulated conductors made using insulated conductors.

The reliability of the work of insulated conductors compared to non-insulated ones is the absence of climatic influences, for example, under the direct influence of wind and ice, the conductors do not break due to contact with tree branches. Due to the use of insulated conductors with mechanical strength, it is practically impossible to break the conductors. It is impossible to short-circuit conductors through various objects [10,15].

In self-insulated conductor insulation, damage detection is carried out to identify conductors with damaged insulation and the location of the damage.

Detection of damaged conductors is carried out by checking the insulation of each current conductor with respect to the neutral conductor and between the current conductors. Tests are carried out with a 1000 V megohmmeter after

disconnecting all consumers from the line.

Table 2. List of Airline Control Measures

1. Insulation monitoring	The condition of insulators and insulating products is controlled by external inspection.
2. Measurement of insulation resistance	Measurement of the resistance of porcelain insulators is carried out only with a megohmmeter for a voltage of 1000 V at a positive ambient temperature. The resistance of each insulator should be at least 300 MΩ.
3. Measuring voltage between ESS insulators	It is manufactured in support and tension wreaths with porcelain insulators in overhead lines, supported at positive ambient temperature.
4. Remote control of isolators	Control is carried out using infrared or electronic-optical devices.

The methods for detecting losses in high-voltage insulated wires are the same as for open conductors. The pulse method is used to determine the place of waste, induction and acoustic methods are used to determine the place of damage. After testing the SIP cables, all conductors should be grounded for a short time to remove the charging current. Automated energy recording systems developed for low-voltage networks do not have the function of monitoring the insulation condition. In practice, independent systems are used to monitor the condition of insulation in high-voltage networks.

Let's consider the capabilities of the proposed computerized insulation control and management system. One of the functions of the system is to provide the network manager and operational personnel with information on the insulation status of the network with respect to ground.

The system consists of a high-voltage power unit and a microprocessor control unit with interface elements with external circuits.

The microprocessor controls the insulation status of electrical consumers in the network with respect to the ground and, in the case of a single-phase ground fault, using information from zero-sequence current transformers. It consists of identifying damaged points, identifying phase breaks, lightning protection of the substation, opening the power unit of this phase according to a certain cyclorama, creating conditions for arc damage and extinguishing point to create conditions for restoring insulation by reducing insulation.

At the same time, electrical and fire safety conditions are improved at the location of the device.

In phase tracking mode, the current value is continuously monitored through a grounded circuit. Depending on the security situation, when the system parameters exceed a certain dangerous value, the switch is activated, the system is turned off and blocked.

If the fault has a relatively small contact resistance, the distance to the fault is determined by switching on the undamaged phase for about 150 msec.

It can also be widely used for cable diagnostics and monitoring. It can continuously monitor the technical condition of the insulation of up to 30 cable lines under a voltage of 6-10 kV. All monitored cable lines are connected to the switch and their working conditions are always under control.

The use of such a multi-channel monitoring system allows to reduce the overall costs of the monitoring and diagnostic system. On the other hand, it allows for more efficient tuning of high-frequency interference receivers in controlled equipment.

Most of the technical solutions aimed at continuous insulation monitoring mainly involve the use of some test signal set to the fundamental frequency without disconnecting the power line.

Such methods consist in supplying a non-industrial frequency signal to the network through an additional transformer, the secondary windings of which are connected to the phases of the controlled network, and the zero points are connected to the ground with an additional Z0 resistor. The signal generator G1 must be connected to the primary winding of the transformer. Figure 1 shows the functional diagram of the device that implements the method of continuous monitoring of the insulation of the system.

The device works as follows: the operating voltage produced by the G1-Generator supplies the phase conductors of the controlled network. The output signals of current transformers TA1 - TA3 passing through bandpass filters are subtracted from the X4 bandpass filter signal and fed to differential amplifiers. The signals of differential amplifiers 1, 2, 3 reach the synchronous and asynchronous detectors and the limit element in proportion to the impedances of phases A, B, C, respectively 7. the reference voltage of one of the windings of the additional transformer and the division into active and reactive power are recorded by measuring elements 10, 15.

In order to continuously and automatically determine the insulation resistance and capacity of a network with a grounded neutral to the ground, this device allows timely diagnosis of the insulation condition to increase the level of electrical safety during the operation of the network.

In a network with a voltage of up to 1000 V with an earthing neutral, the influence of the value of the insulation

capacity with respect to the earth on the value of the breakdown current passing through the insulation and, accordingly, the level of electrical safety of the network was provided.

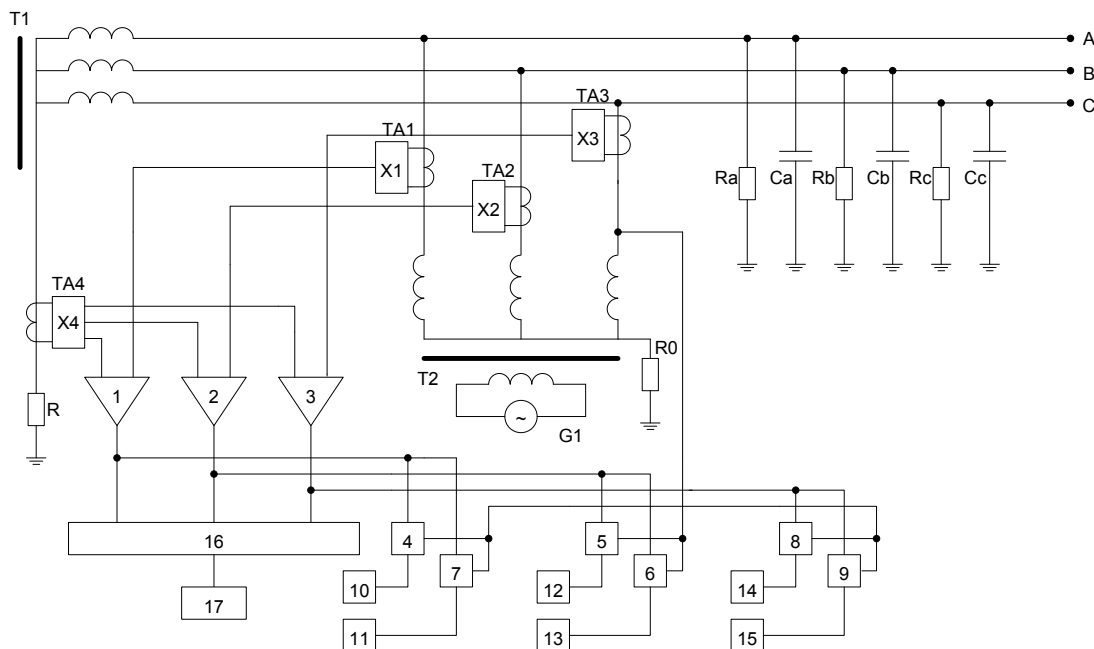

Fig.1. Functional diagram of insulation monitoring device

The considered network includes very common small power consumers up to 1,5 kW. During its operation, a significant part of failures in electrical consumers is caused by damage to the insulation of the coil, which accounts for 85-95% of the total number of motor failures. The percentage of damage to the pipe insulation is calculated as follows. 93% - intermediate coils, 5% - phase windings, 2% - body. Damage to any electrical consumers increases the probability of a short circuit in the body of this motor and leads to its failure and, as a result, a violation of technological modes.

The problem of protection of uninsulated conductor lines from single-phase short circuits to the ground is one of the important tasks. Supply of electricity to consumers is carried out mainly through overhead power lines made up of non-insulated conductors.

Analysis of accident statistics from various information sources shows that 40-50 damages are caused to 100 km of power lines every year. About 62% of them are dangerous for humans and animals. The most common fault in overhead lines is single-phase short circuits to ground. This results in the generation of currents and step voltages, which are dangerous for people and animals and can also cause fire.

To protect against single-phase short circuits, current protection based on the use of fuses and automatic circuit breakers is most commonly used in electrical networks with an earthed neutral. Based on the research results, the protective coverage of these devices applies only to the first part of the network and in some cases does not exceed 100-300 m, depending on the power of the supply transformers.

The device is designed to protect networks from open-phase modes caused by cable breaks and increase the level of electrical safety. When the phase conductor is broken, the computerized measurement and control device sets the negative sequence voltage changes at the end of the line with its short-circuit effect. Creates an artificial short circuit, the power line protection installed on the head automatically disconnects from the source. The device consists of an inverse sequence voltage filter, limiting devices, a time-interval hold adjustment device and an executive device.

A device of the type of computerized measurement-control device is connected to the neutral and line cables at the end of the protected part of the line (Fig. 2).

Under normal operating conditions of the overhead power line, there is a balancing voltage signal at the output of the reverse sequence voltage filter, which is not sufficient to operate the filter and the limiting device based on the value of the controlled network indicators.

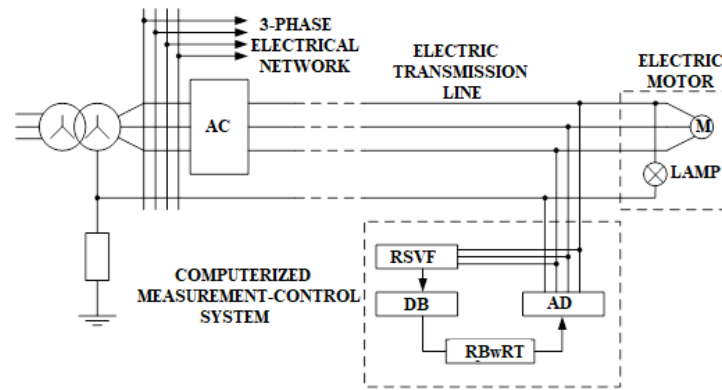

Fig. 2. Structural diagram of the connection of the computerized measurement and control device to the electrical network

When the reverse sequence voltage filter RSVF- output is disconnected in the line, the voltage spikes, triggering the software. The adjustment device causes the AD control time CT delay to work with them. After a predetermined time, the signal from AD arrives at the ED input of the playback device. When the line is activated, the artificial ED creates a two-phase short circuit to earth. An automatic circuit breaker AC installed at the beginning of the controlled line eliminates this short circuit. The short-circuit device has an additional circuit breaker that uses the electrical energy of the short-circuit current for more reliable operation. After disconnecting the line and eliminating the conductor break, the device will automatically return to its original state.

Based on the above power supply scheme, we will develop its mathematical models.

Figure 3 shows the equivalent circuit for one phase of a three-phase power supply with electrical energy consumers. We can simplify the model of this scheme to accurately calculate the data. We can symmetrically distribute the load in the electric network by phases. We distribute the load of electricity consumers equally to the network. Taking the same average values of electricity consumers, we get the daily consumption in each sale. In this way, we ensure the conductor symmetry of the input voltage and take the current in the zero phase as zero.

The electrical equivalent circuit consists of the following elements:

- z -Resistance of the line at a distance of 100 m of one phase between EE consumers, Ohm;
- y -Consumer load, optional mince can be given,
- I_k - EE current of consumers, A;
- J_k -line current, A;
- $II1, II2$ - the extent of insulation allowed, A;
- U_k -EE consumer voltage, V;
- S_k -digital counters;
- Sk -Current controller.

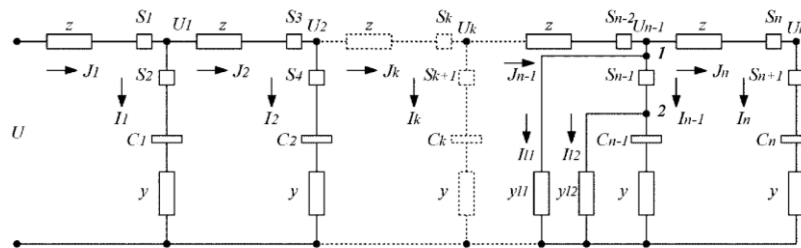

Fig. 3. Equivalent circuit for one phase of a three-phase power supply line

The active and inductive resistances of the line and the sub-subunits of the line are also taken into account. It is not taken into account due to the smallness of the capacitance.

We use the created current controller in two ways:

The first is in all parts of the line and at the entry points of all electricity consumers. It is installed after the counter.

The second is the current controller in all parts of the power line. It is not necessary to install electricity consumers.

We use digital meters to transmit data without a current controller. A digital counter is also needed to collect statistical data to ensure continuous operation of the devices. We choose the method of installation of the current control device based on the proposal of the line and the district electric network company, because it depends on the financial costs.

It is known to us that one feeder has residents living in several residential complexes and three-phase consumers. It is expensive to install each current controller separately. If it is necessary to control the electricity consumption of the electric network, it is necessary to install several current monitoring devices at the same time on single and three-phase lines. The above points should be taken into account when using a current control device.

When installing a current control device, it is necessary to take into account the characteristics of the conductor.

Placement of devices taking into account the technological waste of the network allows to monitor and control the average values of current and voltage in the network. Electricity and power balances in real time also identify places of unauthorized connection to electricity. It compares the voltage and current values with the meters, taking into account the exact state of the network. The cost of installing such a current controller is expensive. But it is convenient and clear to control the operating modes of networks through such an installation. The location of the current controller after the meter is reliable.

The current monitoring device only takes the value of the current in the line sections of the installation of the electric line parts. Based on the exact values of the voltage and current in the line sections, calculates the voltage and current in the electricity consumers. Monitors power balances in real time, taking into account technical waste of electricity.

In Figure 3, electricity from node Un-1 allows to determine the places of unauthorized electricity connections in parts 1 and 2. Let's consider the processes that occur in currents I11 and I12. When an unauthorized load is connected to the network at node 1 in the figure, the current controller I11 is an error in the load Sn-2, and its direction is calculated by expressions 1 and 2, formulated according to Kirchhoff's first law.

$$J_{n-1} = I_{n-1} + J_n \tag{1}$$

$$J_{n-1} = I_{n-1} + J_n + I_{11}. \tag{2}$$

When determining places of unauthorized connection to electricity, current vectors consisting of the current measured at the branches of the power line and the current of consumers are constructed. We construct raw vectors for the case where all elements in the scheme are zero. After the counter, the vector of the difference in the basic data will not be equal to zero to determine the location of unauthorized connections and electricity consumption.

Unauthorized load connected to the network is correlated for the current for the case connected to the 2nd part of the circuit, but the balance of the active power is disturbed. These equilibrium equations are given in expressions 3 and 4.

$$P_{n-1} = P_k - P_{ik}, \tag{3}$$

$$P_{n-1} = P_k - P_{ik} - P_{il}. \tag{4}$$

The maximum power of the network Sk, the indicators of the electricity meter, the directions of the power Pk and Pn-1 are determined from the known measured values.

Based on the above, it is possible to determine the location of unauthorized electricity connection with a probability of almost 100% as a result of installing current control devices on the line and consumers.

3 and 4 allow definition of active power and determination of power factor. This allows the controller to use the current to perform additional tasks.

To solve this problem, it is more promising to use non-insulated conductors in controlled areas and compare the current at the beginning and end of the line.

3. Results and Discussion

For example, we consider the modes of operation of consumers with and without unauthorized connection to the power grid. Calculations were performed at a load power factor of 0.75.

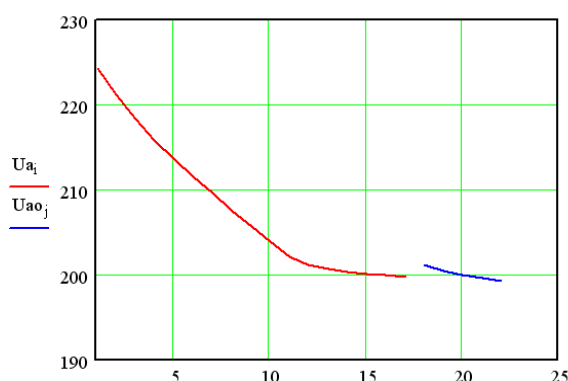

Fig. 4. Change in voltage in phase A

The voltage across the main supports 1 - 17 is linear in red, and from the main support 11 it is observed to change non-

linearly. Discontinuities are shown in blue, mainly bases 18-22 (Figure 4). It can also be seen in the line currents that the voltage drops in the same direction in the line phases (Figure 5).

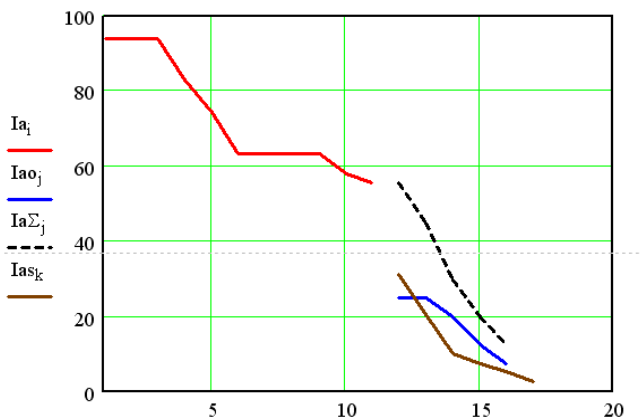

Fig. 5. Current variation in phase A

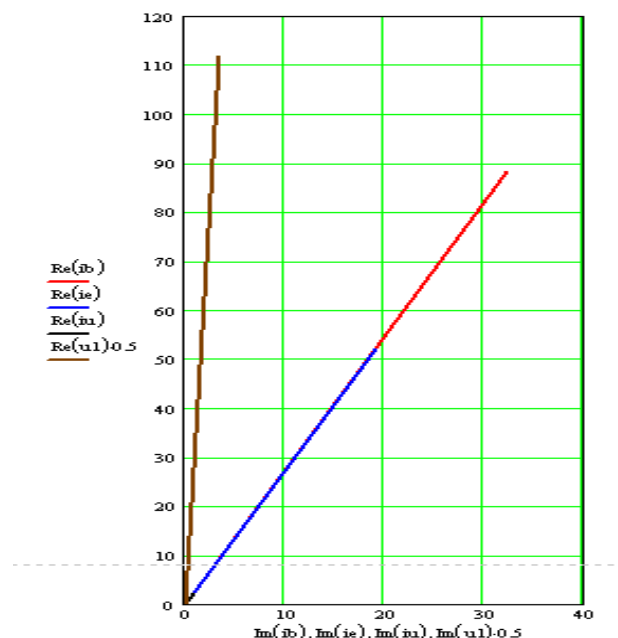

Fig. 6. Current and voltage vector diagram of phase A: $u1$ - voltage at the head of the brown electrical network; ib - red current at the beginning of the electrical network; the current between the electrical network is blue; iu is the current at the end of the black electrical network

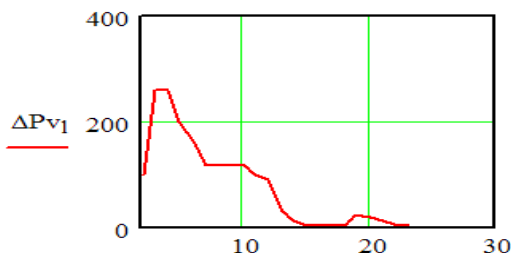

Fig. 7. Change of technological waste in phase A

In Figure 6, the red color shows the current at the beginning of support spans 1 to 11; in brown, between 12 and 17 supports, in blue between 18 and 22 supports, and in black at the end of the network. It can be seen that the network is working stably. The insulation condition of the tram is good. No unauthorized connections.

In this graph (Figure 7), the change in process waste is obtained by active power, and the process waste is increased

only due to the transient process that occurs in the start-up mode and then it fell to the norm. In the next operating mode, $\cos\varphi=0,7$. We get analytical graphs of unauthorized connection of consumers to the power grid with a power factor of 0,55 and 1 kW.

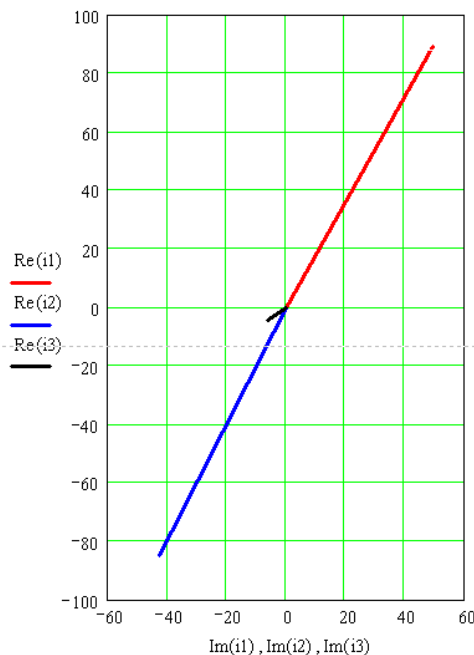

Fig. 8. Vector diagram of the current in the circuit 1 and 2 at the beginning of the electrical network

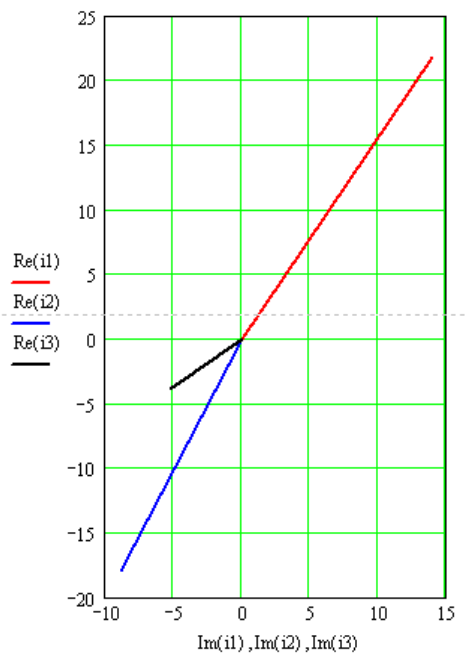

Fig. 9. 11, 12, 13 intermediate current vector diagrams of the electrical network

It is possible to determine where there are unauthorized connections in different places of the graph (Figure 8): basically, the presence of unauthorized connections can be seen from the current values at the beginning, middle and end of the electrical network. i_1 - red color at the beginning of the electrical network; i_2 - the current at the end of the blue color and i_3 - the current from the unauthorized connection to the electrical network is given in black (Figure 9, 10).

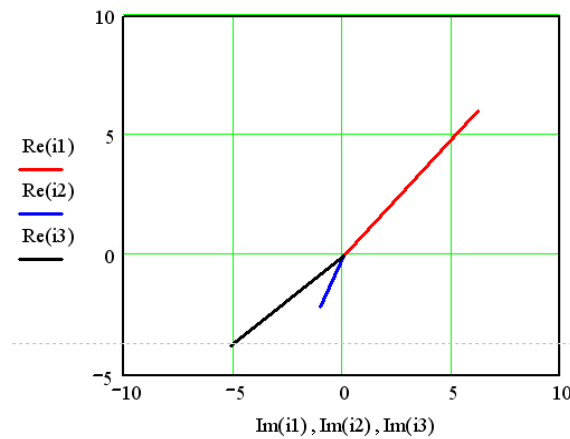

Fig. 10. Current vector diagram in the last part of the electrical network 12, 16, 17

Table 3 shows the places of unauthorized connection to electricity in phase A of the electrical network and the values of current in the phase. The letter *i* is the instantaneous value of the current in phase A. *i_{fb}* - at the beginning of the phase, *i_{fo}* - at the end of the phase, *i_{ru}* - current values in unauthorized connections and I phase.

Table 3. places of unauthorized connection to electricity in phase A of the electrical network and the values of current in the phase

Parts of phase A	Active power of consumers connected to electricity without authorization, kW					
	12	12 - 13	16 - 17	12	12 - 13	16 - 17
<i>i_{fb}</i>	97,7-j42,25	22,2-j13,3	6,34-j6,5	95,8-j39,2	20,1-j10,13	4,3-j3,6
<i>I_{fb}</i>	107,13	24,91	9,25	104,11	21,95	5,87
<i>i_{fo}</i>	93,9-j35,4	18,1-j7,1	2,5-j1,1	93,9-j36,3	17,9-j6,9	2,8-j1,1
Expression	100,61	18,91	2,75	100,65	18,88	2,77
<i>g_o</i>	4,65-j6,47	4,01-j6,05	4,11-j6,1	2,4-j3,5	2,03-j2,45	2,0-j2,9
<i>I_{ru}</i>	8,1	6,78	6,87	4,22	3,65	3,98
<i>I_{ru} / I_{fb}</i>	6,95	26,87	75,56	3,85	18,2	60,0
$\frac{I_{fo} - I_{fb}}{I_{fb}}$	6,22	22,98	73,01	3,06	12,99	55,36
Error, %	17,03	14,02	4,89	19,01	25,2	7,99

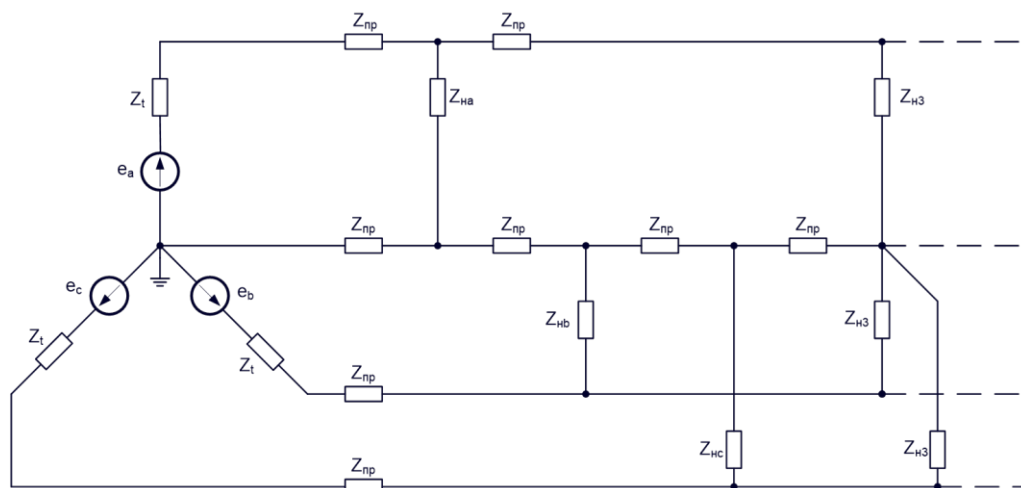

Fig. 11. Equivalent circuit of the electrical network

As can be seen from the last row of the table, the imbalance in the current value in the electrical network causes an error of 4,89 to 25,2%.

As a mathematical model of the electrical network, the equivalent circuit created in the phase coordinate system includes all current-carrying elements of the electrical network, transformers and consumers of electricity. In Figure 11, we can see a part of the equivalent circuit of the head of the line.

In the equivalent scheme, Z_t is a step-down power transformer, Z_{pr} is a line wire, Z_{one} , Z_{nb} , Z_{nc} are single-phase and Z_{n3} are three-phase consumers. EP in the transformer phases is equal to the phase voltage that increases by 5% with a phase shift of 1200.

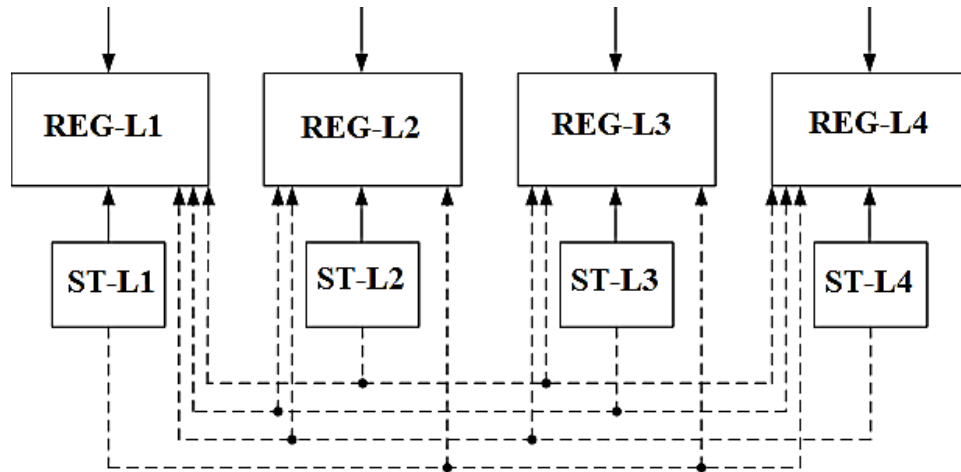

Fig.12. The structural scheme of the program developed for calculating the electrical network sizes

A large number of nodes and points of an equivalent circuit makes it necessary to describe its topology using a directed graph, which is divided into parts along separate lines. For this, the initial information about individual lines is placed in separate files of the program for calculating network modes, as shown in the block diagram of the program (Fig. 12). In the upper row of the diagram above, there are modules for calculating the operating mode of individual network lines, and in the second row there are modules for the initial data of these lines. These modules are programmed based on the following mathematical models.

$$\begin{aligned}
 \text{Form_P}(V, U_{zl}, s) &:= \begin{cases} \text{for } i \in 1 \dots \text{rows}(V) \\ \quad n \leftarrow V_{i, s+1} \\ \quad k \leftarrow V_{i, s+2} \\ \quad \text{if } n \neq 0 \\ \quad \quad \text{rw} \leftarrow \text{Poz}(n, U_{zl}) \\ \quad \quad P_{\text{rw}, i} \leftarrow -1 \\ \quad \quad \text{if } k \neq 0 \\ \quad \quad \quad \text{rw} \leftarrow \text{Poz}(k, U_{zl}) \\ \quad \quad \quad P_{\text{rw}, i} \leftarrow 1 \\ \quad P \end{cases} \\
 \text{Poz}(n, U_{zl}) &:= \begin{cases} \text{for } j \in 1 \dots \text{length}(U_{zl}) \\ \quad \text{if } U_{zl}_j = n \\ \quad \quad \text{pz} \leftarrow j \\ \quad \quad \text{break} \\ \quad \text{pz} \end{cases} \\
 Y_v &= [\text{diag}(Z_v)]^{-1}, \\
 Z_v &:= V^{<4>}. \\
 Z_t(U_k, P_k, S_n) &:= \begin{cases} r \leftarrow \frac{P_k \cdot U_n^2}{S_n^2 \cdot 10^3} \\ r + \sqrt{\left(\frac{U_k}{100}\right)^2 - \left(\frac{P_k}{S_n}\right)^2} \cdot \frac{U_n^2}{S_n \cdot 10^3} \cdot i \end{cases}
 \end{aligned}$$

$$\begin{aligned}
 \text{ng1}(P, \text{co}) &:= \begin{cases} z \leftarrow \frac{220^2 - 0.001}{P - \frac{P}{\text{co}} \sqrt{1 - \text{co}^2} \cdot i} \\ zr \leftarrow z \cdot (0.5 + \text{rnd}(1)) \text{ if } \text{fr} = 1 \end{cases} \\
 \text{ng3}(P3, \text{co}) &:= \begin{cases} P \leftarrow \frac{P3}{3} \\ z \leftarrow \frac{220^2 - 0.001}{P - \frac{P}{\text{co}} \sqrt{1 - \text{co}^2} \cdot i} \\ zr \leftarrow z \cdot (0.5 + \text{rnd}(1)) \text{ if } \text{fr} = 1 \\ Z_{\text{u}} = Y_{\text{u}}^{-1} \end{cases} \\
 \text{Uteth}(\text{pr}, \text{Pu}) &:= \begin{cases} \text{for } i \in 1..Nv \\ \quad \begin{cases} o \leftarrow V_{i,1} \\ lo \leftarrow \text{strlen}(o) \\ lpr \leftarrow \text{strlen}(\text{pr}) \\ \text{if } \text{search}(V_{i,1}, \text{pr}, 0) = 0 \wedge lo = lpr \\ \quad \begin{cases} v1 \leftarrow \text{submatrix}(V, 1, i-1, 1, 4) \\ v2 \leftarrow \text{submatrix}(V, i+1, Nv, 1, 4) \\ v3 \leftarrow \begin{pmatrix} \text{concat}(\text{pr}, \text{"Ut"}) & V_{i,2} & \text{"Ut"} & V_{i,4} \cdot 0.5 \\ \text{concat}(\text{"Ut"}, \text{pr}) & \text{"Ut"} & V_{i,3} & V_{i,4} \cdot 0.5 \\ & \text{"ut"} & \text{"Ut"} & 0 \end{pmatrix} \\ \text{Vn} \leftarrow \text{stack}(v1, v2, v3) \end{cases} \end{cases} \\ \text{Vn} \end{cases} \\
 \text{Obruv}(\text{pr}, \text{Rz}) &:= \begin{cases} lpr \leftarrow \text{strlen}(\text{pr}) \\ \text{for } i \in 1..Nv \\ \quad \text{if } \text{search}(V_{i,1}, \text{pr}, 0) = 0 \wedge \text{strlen}(V_{i,1}) = lpr \\ \quad \quad \begin{cases} io \leftarrow i \\ \text{break} \end{cases} \\ v1 \leftarrow \text{submatrix}(V, 1, io-1, 1, 4) \\ v2 \leftarrow \text{submatrix}(V, io+1, Nv, 1, 4) \\ v3 \leftarrow (\text{concat}(\text{pr}, \text{"Ob"}) \quad V_{io,2} \quad 0 \quad \text{Rz}) \\ \text{Vn} \leftarrow \text{stack}(v1, v2, v3) \\ \text{Vn} \end{cases}
 \end{aligned}$$

The graph description is made in the form of a matrix of the first and last nodes of the branches of the equivalent circuit. To increase the visibility and visibility of the results of such a large number of elements, a traditional description of the nodes and branches of the simulated electrical network was first used.

Secondly, taking into account the relative independence of the operation of parallel connected lines, the distribution network model uses the initial equivalent of all other lines adjacent to one, for which a detailed calculation is made.

Among the features of the developed distribution network model is the possibility to consider the mutual induction between the conductors of two lines whose sections are located on the same supports.

4. Conclusions

The computerized insulation control and management system performs the following diagnostic functions:

1. Continuous monitoring and analysis of the insulation condition of the high-voltage cable line. Determining the type of defect in insulation, its development level and analyzing its risk.
2. The system is implemented by automatic localization of places where insulation defects appear, detected by partial discharges, both in the couplings and in the cable itself. The uniqueness of this important diagnostic function is realized in "on-line" mode. That is, cable lines or electrical networks are also monitored under voltage.
3. As a result of the comparison of the currents between the supports in the phase, it is possible to make unauthorized

connections to the electrical network.

4. By assessing the condition of the insulation, it prevents electrical consumers from breaking down due to accidents and the costs of emergency repairs.

References

1. N.N. Mirzoyev, Information software and devices for energy efficiency management and control, *Chemical Technology, Control and Management* **5**, 68-75 (2021)
2. N.N. Mirzoyev, Analogical Model Development Methodology For Mathematical Modeling Of Energy Efficiency Control System, *The American Journal of Engineering and Technology* **02**, 55-61 (2020)
3. N.N. Mirzoyev, Intelligence devices for monitoring and control of energy efficiency of enterprises, *Chemical Technology. Control and Management* **5-6**, 172-181 (2020)
4. N.N. Mirzoyev, O.H. Sayfiyev, T.O. Temirov, Investigation of unauthorized connection to electrical networks, failure to detect their phase interruptions and short circuits to ground, *ResearchJet Journal of Analysis and Inventions* **3**(10), 130-143 (2022)
5. N. Mirzoyev, S. Sobirov, Study of violations of quality indicators of electricity supply network, *Central Asian Journal of Education and Innovation* **28**, 83-86 (2023)
6. N. Narzullo Mirzoyev, O. Shohjahon Sobirov, Computerized measurement control system of unauthorized connection to electrical networks and isolation control detection, *Science and Education* **25**, 488-502 (2023)
7. I.Kh. Siddikov, A.A. Abdumalikov, M.T. Makhsudov, The Dynamic Characteristics of Sensors of Primary Currents of Energy Sources to Secondary Voltages, *International Journal of Innovative Technology and Exploring Engineering* **9**, 2529-2534 (2020)
8. M.T. Makhsudov, D.D. Karimjonov, Research of dynamic characteristics of current converters for control and management of reactive power of asynchronous motors, *Problems of energy and resource conservation* **3**, 240-248 (2021)
9. Z.U. Boixanov, I.X. Siddikov, D.D. Karimjonov, Software for monitoring and evaluating the reactive power of an induction motor, Certificate of official registration program for electronic-highlight machine, № DGU 16087
10. I.Kh. Siddikov, A.A. Abdumalikov, M.T. Makhsudov, Modeling and research multiphases signal transducers of power control systems, 2020 International Conference on Information Science and Communications Technologies (ICISCT 2020), Hunan University of Finance and Economics, Hunan (2020)
11. I.X. Siddikov, M.T. Makhsudov, D.D. Karimjonov, Research of static characteristics of three-phase current sensors for control and monitoring of asynchronous motor filter-compensation devices, International Conference on New Intelligence Technology: Past, Present and Future, Turin Polytechnic University in Tashkent, Tashkent (2022)
12. S.F. Amirov, D.Sh. Rustamov, N.K. Babanazarova, Research of dynamic characteristics of electromagnetic current transducer, *European Science Review* **3-4**, 95 (2019)
13. D.D. Karimjonov, Control and management of an asynchronous motor based on a current converter signal, *Scientific-technical journal NTJ FerPI* **25**, 85-90 (2021)
14. A.E. Fitzgerald, Jr. Charles Kingsley, S.D. Umans, Electric machinery, Power and energy, McGraw-Hill, New York (2003)
15. I.X. Siddikov, D.D. Karimjonov, Research of the effect of rotor parameters on the output signal of an asynchronous motor three-phase current converter, *Scientific and Technical Journal Machine Building* **2**, 139-146 (2022)
16. I.Kh. Siddikov, Z.U. Boikhonov, D.D. Karimjonov, Elements and Devices for Monitoring and Control of Energy Efficiency, *The American Journal of Engineering and Technology* **29**, 136-148 (2020)
17. H. Schaumburg, Werkstoffe und Bauelemente der Elektrotechnik, Sensoren, Stuttgart (1992)
18. I.X. Siddikov, Z.U. Boixanov, Current-to-voltage converter, Patent. № FAP 01943
19. H. Schaumburg, Werkstoffe und Bauelemente der Elektrotechnik, Sensor-anwendungen. Stuttgart (2012)
20. H. Schaumburg, E. Ritchie, R.Kh. Khamdamov, A.A. Adilov, D.D. Bistrov, T.Z. Zakirov, A.Kh. Abdullaev, M.N. Musaev, I.Kh. Siddikov, Sh.Sh. Kayumov, B.A. Mazgarov, M.O. Kim, Long Distance Training in Uzbekistan, The final report of the Project EC T JEP-10845-99. TUHH – Gamburg – Harburg (Germany), AAU – Aalborg (Denmark), TashGTU, Tashkent (1999-2004)
21. I.X. Siddikov, M.T. Makhsudov, D.D. Karimjonov, Method of determination of stator current and power factor based on asynchronous motor three-phase current sensor, *Chemical technology control and management* **2**, 30-38 (2022)
22. I.X. Siddikov, M.T. Makhsudov, D.D. Karimjonov, Electromagnetic current converters for control of reactive power sources, *Scientific and technical journal machine building* **3**, 103-110 (2022)