

# Improvement of hydraulic parameters of heat supply water heating boilers

*Aybek Arifjanov*<sup>1</sup>, *Kozim Kurbanov*<sup>2</sup>, and *Sardor Xoshimov*<sup>1\*</sup>

<sup>1</sup>National Research University “Tashkent Institute of Irrigation and Agricultural Mechanization Engineers”, Kari Niyazov 39, 100000, Tashkent, Uzbekistan

<sup>2</sup>Namangan Engineering-Construction Institute, Islam Karimov street, 12, Namangan, Uzbekistan

**Abstract.** Practical and theoretical research has been carried out to optimize thermal energy use and incorporate energy-saving methods in consumption and production processes. This article presents an analysis of research on heat transfer by improving its hydraulic parameters in order to increase the energy efficiency of water heating boilers designed for heat supply of private residences and social facilities today. The research includes both practical experiments and theoretical analysis to ensure efficient thermal energy utilization. A program was developed to use the least squares method for analyzing test results on pipes of various cross-sections, aimed at evaluating the efficiency of heat transfer surfaces. The study found that pipes with corrugated inner walls in heat exchangers exhibited 15-20% higher efficiency compared to regular pipes, enhancing the plant's thermal energy efficiency. Implementing the proposed device for boiler pipes in manufacturing enterprises could allow for the construction of additional facilities, such as greenhouses, fruit drying shops, and service buildings. This innovation enables the production and use of low-cost hot water, potentially generating additional income in the production of bricks or porcelain.

## 1 Introduction

In 2020, coal power contributed to 35% of global electricity generation [1]. Although advanced countries are reducing their reliance on coal due to CO<sub>2</sub> emission-reduction efforts, coal is expected to remain a significant power source for the foreseeable future [2]. Additionally, NO<sub>x</sub> emissions from coal combustion are a major concern because they contribute to the formation of secondary particulate matter in the atmosphere [3]. Therefore, achieving clean and efficient combustion in coal-fired power plants is essential to minimize environmental impacts [4].

To reduce NO<sub>x</sub> emissions, primary measures such as air staging and low NO<sub>x</sub> burners, and secondary measures like selective catalytic reduction, are widely used in commercial plants [5]. In air staging, most of the combustion air (70%-90%) is supplied with the fuel in the burner zone, creating a fuel-rich atmosphere with low flame temperatures, which moderately suppresses NO<sub>x</sub> formation. The remaining combustion air (10%-30%) is

---

\* Corresponding author: [xoshimov.50907@gmail.com](mailto:xoshimov.50907@gmail.com)

introduced above the burner zone as burnout air or overfire air through air ports or nozzles to complete combustion. The placement of the injection ports and the mixing of OFA jets with hot gases are critical for achieving efficient combustion with low NO<sub>x</sub> levels [2, 6]. Energy efficiency has become a crucial issue today. As living standards improve, energy consumption grows. Achieving efficient heat production involves optimizing boiler load to make the best use of energy. Another significant concern is protecting the environment from pollution. Burning various fuels for heat or energy releases emissions that can harm the environment. Reducing emissions from heating plants during production is a key solution to improving air quality. One way to improve fuel efficiency is by developing high-performance domestic energy equipment, particularly compact hot-water boilers for autonomous heating systems [7]. Enhancing boiler efficiency involves lowering the temperature of the exiting flue gases, which can be accomplished by adding extra heating surfaces [8, 9].

The potential of preheating and humidifying the combustion air to enhance boiler efficiency and reduce harmful emissions in flue gases was examined. Boiler efficiency values were measured before and after implementing this system, and flue gas analysis was conducted using a Testo 350 analyzer to determine the impact on emissions [8]. The article explores different configurations for a water boiler and a remote economizer, and it includes preliminary design calculations for the economizer using various boiler layout schemes in the Boiler Designer software. Based on the study results, a configuration with a three-way boiler and a two-way remote economizer was selected. The proposed design features a three-way fire tube hot water boiler and an external economizer with internally arranged collectors, positioned above the boiler in a block-modular boiler house. This setup facilitates servicing both the remote economizer and the hot water boiler. Thermal, hydraulic, and aerodynamic calculations for the newly developed fire tube boiler were conducted using the Boiler Designer software package. The boiler design was optimized to achieve the necessary 94% efficiency for crude oil combustion [9, 10]. Coal is currently one of the primary fuels used for thermal energy. Despite being the most affordable and economically viable option, coal usage comes with several drawbacks, including significant heat losses due to incomplete combustion and adverse environmental impacts from harmful emissions. Consequently, low-power solid-fuel hot-water boilers are commonly used for heating and hot water supply. This method has both benefits and downsides. On the positive side, solid-fuel hot-water boilers can reduce thermal energy costs and enhance energy independence [11]. On the negative side, they can increase harmful emissions, particularly when fuel quality is poor and combustion efficiency is low [12, 13]. For this reason, many studies are being conducted by scientists of the world aimed at creating technical specifications necessary for the development of perfect technological and structural parameters that increase the energy efficiency of thermal energy processes and devices, as well as control schemes that ensure the continuity of hydrodynamic and thermal processes [14]. In particular, attention is being paid to the production of modern energy-efficient water heating boiler devices based on the improvement of the calculation methods of the heat-carrying current, hydraulic resistances and structural parameters and changing the elements of the heat-carrying current [15].

In the territory of our republic, many social facilities, including pre-school educational institutions, schools, family polyclinics and other public buildings are provided with individual boilers for heating in the winter season. These heating boilers work on solid fuel (coal) and natural gas. FIK (efficiency coefficient) of these heating boilers does not exceed 70-75%. In this regard, complex measures are being implemented to improve the efficiency of the heat supply system in order to use energy sources rationally [16, 17]. In addition, in the development strategy of the President of the Republic of Uzbekistan for the period of 2022-2026, including "...development of the engineering communication and social infrastructure system of the regions and the service and service sectors, as well as housing - in order to create comfortable conditions for the population in public utilities, social sector

facilities and other areas, the important tasks are defined on the wide introduction of efficient and renewable sources of energy in providing heat to buildings. Therefore, today, the creation of energy-efficient heating boilers, taking into account the movement of heat flow in various modes and heat exchange processes in heating boilers, remains one of the most urgent issues [18, 19].

## 2 Materials and methods

To assess the efficiency of thermal processes in a boiler, we employ a method that integrates the principles of the First and Second Laws of Thermodynamics. The energy balance method is utilized for the thermodynamic evaluation of boiler efficiency. This approach is grounded in established research by K.F. Roddatis, A.N. Poltoratsky, V.M. Fokin, E.G. Volkovyskiy, N.B. Lieberman, and Yu.L. Gusev. Additionally, the works of A.V. Vikhrov and L.K. Ramzin, which explore solid fuel combustion organization and the design features of boiler units with layered construction furnaces, are noteworthy [12]. An experimental device was created in order to increase the efficiency of the pipeline of the heat supply device. During the preparation of the experimental device, the existing heat exchange devices were familiarized. The preparation of the experimental device was based on a small sample of the existing boiler device [16, 20].

In the construction of the experimental device, we used a steel pipe with an outer casing diameter of 250 mm, a length of 1.10 m, an internal heat pipe diameter of 50 mm, a length of 0.7 m (Fig. 1). By changing the outer surface of the inner tube of the experimental device, it is necessary to evaluate the heat transfer efficiency of this device.

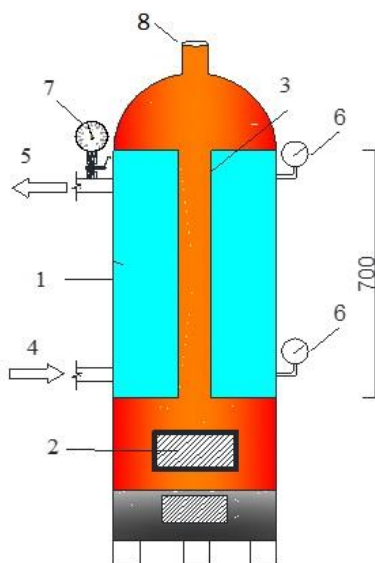

**Fig. 1.** General view of the laboratory device: 1-boiler body, 2- fuel stove, 3- heat moving pipe, 4- return heat carrier 5- heat carrier flow to the heat system, 6- temperature gauge, 7- manometer, 8- fume hood.

The main purpose of conducting experimental work is to determine the coefficient of heat transfer of the pipe of the heat supply device. In the implementation of this task, the heat supply efficiency has been increased by changing the outer surface of the internal pipe of the heat supply device with the help of special ribs. Experiments in laboratory conditions were

carried out in the following order. Initially, the dimensions of the outer surface of the internal pipe of the boiler device are  $0.2 \times 1.4 \times 70$  sm. with one rib installed (Fig. 2) and its heat transfer efficiency was determined.[21-26]

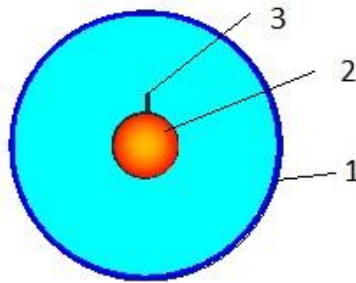

**Fig. 2.** Cross section of a single rib boiler unit: 1. Outer casing, 2. Heat carrier inner tube, 3. Rib.

The boiler unit created in the laboratory study was filled with 19.5 liters of water at a temperature of 20 0C, and then coal fuel was burned in the boiler unit. The temperature of the heated water was monitored using a thermometer installed in the boiler device, and the experimental test process was continued until it reached 95 0C. When the temperature of the water in this boiler device reached 95 0C, the time taken to complete the experimental process was determined by a stopwatch, and the determined results were recorded in the table. The main purpose of the experiment is to increase the external surface of the internal pipe of the boiler and to reduce fuel consumption. To achieve this goal, several samples of the experimental device were made. At the next stage of laboratory research, we increased the number of ribs installed in the internal pipe of the boiler device as above. That is, the dimensions of the outer surface of the internal pipe of the boiler device are  $0.2 \times 1.4 \times 70$  sm. from one rib to eight ribs, experimental tests were carried out (Fig. 3).

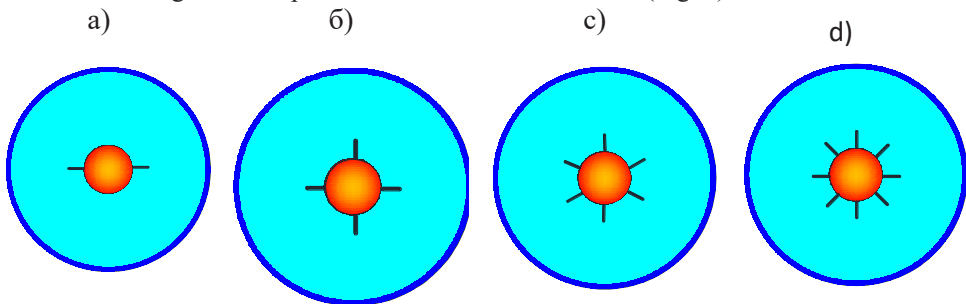

**Fig. 3.** Cutting edge of the laboratory device: a) an internal pipe with two ribs, b) an internal pipe with four ribs, c) an internal pipe with six ribs, d) an internal pipe with eight ribs

### 3 Results and Discussions

As described above, in the laboratory research, the water temperature was filled with the same temperature as the outside air temperature, and the coal fuel was burned and the water temperature was observed to change up to the specified standard temperature. When the temperature of the water in the boiler device reached 95 0C, the experimental process was completed, the time spent on heating the water and the amount of coal used were measured, the results are presented in the following table1.

**Table 1.** Results obtained in laboratory studies

$N_f$	$N$	$t_0, ^\circ C$	$t_1, ^\circ C$	$t_2, ^\circ C$	$\Delta t, ^\circ C$	$T, min.$
1	0	20	79	95	16	66,2
2	1	20	79	95	16	60,9
3	2	20	79	95	16	55,8
4	3	20	80	95	15	52,3
5	4	20	80	95	15	46
6	5	20	81	95	14	44,2
7	6	20	82	95	13	44
8	7	20	80	95	15	43,2
9	8	20	81	95	14	41

The heat transfer efficiency of each experimental device was determined by mathematical statistical analysis of the results obtained in laboratory research. Based on these results, the effect of the fins installed on the boiler device on the heat transfer efficiency and the water heating time was evaluated (Fig. 4).

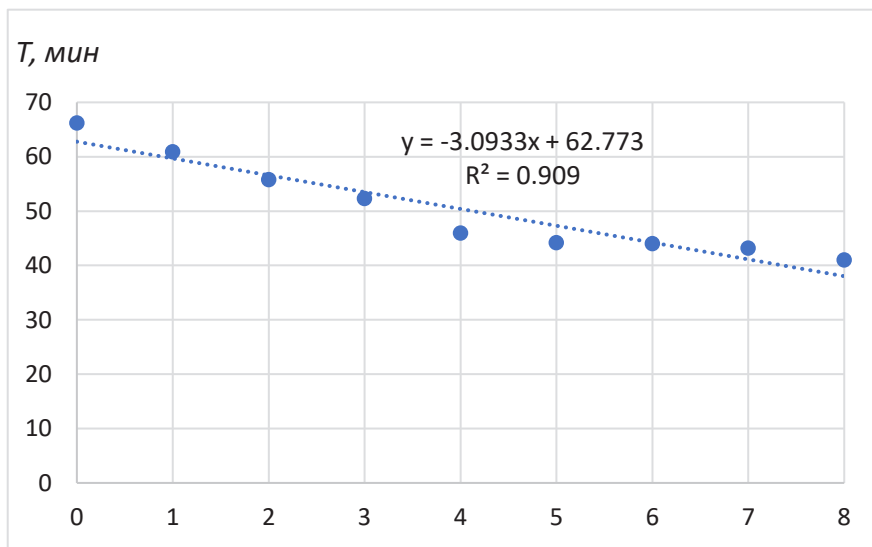

**Fig. 4.** Effect of fins on heat transfer efficiency and water heating time

The analysis of the results of the experiment showed that increasing the number of ribs significantly increases the heat transfer surface and simultaneously leads to a decrease in the volume of water. During the experiment, it became necessary to determine the most optimal parameters of the boiler device. At the next stage, the heating temperature of water and the amount of consumed fuel were measured in the boiler devices created at the next stage. The results were analyzed and the influence of the number of ribs on the water temperature during this period was evaluated.

## 4 Conclusion

As a result of the research, to enhance the thermal efficiency of existing water heating boilers, improved design parameters were developed, and hydraulic calculations were performed.

The heat transfer surfaces were increased by adding additional ribs, which led to a significant increase in thermal efficiency. Specifically, the cross-sectional areas for heat flow were enlarged due to the additional ribs, resulting in a 15-20 % improvement in the thermal efficiency of the water heating boiler.

This enhancement also contributed to saving fuel resources. By increasing the efficiency of water heating boilers used in social facilities, these modifications help conserve the fuel resources utilized. Implementing the proposed device for boiler pipes in manufacturing enterprises could allow for the construction of additional facilities, such as greenhouses, fruit drying shops, and service buildings. This innovation enables the production and use of low-cost hot water, potentially generating additional income in the production of bricks or porcelain.

## References

1. Kim H R, Shin DY and Chung K H 2017 *Toxicol. In Vitro* **38**, 1–7.  
<https://doi.org/10.1016/j.tiv.2016.10.006>
2. Yang J, Sun R, Sun S, Zhao N, Hao N, Chen H, Wang Y, Guo H and Meng J 2014 *Air staging. Fuel Process. Technol.* **126**, 266–275.  
<https://doi.org/10.1016/j.fuproc.2014.04.034>
3. Fan W, Lin Z, Kuang J and Li Y 2010 *Fuel Process. Technol.* **91**, 625–634.  
<https://doi.org/10.1016/j.fuproc.2010.01.009>
4. Huang L, Li Z, Sun R and Zhou J 2006 *Fuel Process. Technol.* **87**, 363–371.  
<https://doi.org/10.1016/j.fuproc.2005.10.008>
5. Park H Y, Lee J E, Kim H H, Park S, Baek S H, Ye I and Ryu C 2019 *Fuel Process. Technol.* **235**, 1377–1386. <https://doi.org/10.1016/j.fuel.2018.08.134>
6. Fan Y, Jin X, Chen H, Hu Y and Gao Z 2024 *Water Resour. Manag.* **38**, 463–479.  
<https://doi.org/10.1007/s11269-023-03680-0>
7. Samiev L, Shaymardanov S, Xoshimov S and Mamadiyrov O 2023 *E3S Web Conf.* **452**, 02019. <https://doi.org/10.1051/e3sconf/202345202019>
8. Zeiza-Seleznova A, Bogdanovičs R and Zajacs A 2023. *J. Sustain. Archit. Civ. Eng.* **33**, 83–95. <https://doi.org/10.5755/j01.sace.33.2.33425>
9. Roslyakov P V, Proskurin Y V and Ionkin I L 2017 *J. Phys. Conf. Ser.* **891**, 012243.  
<https://doi.org/10.1088/1742-6596/891/1/012243>
10. Madejski P and Żymelka P 2020 *Energy* **197**, 117221.  
<https://doi.org/10.1016/j.energy.2020.117221>
11. Samiev L, Shaymardanov S, Xoshimov S and Mamadiyrov O 2023. *E3S Web Conf.* **452**, 02019. <https://doi.org/10.1051/e3sconf/202345202019>
12. Khujaev P, Kholmuratov T, Ismatullozoda J and Shakirov R 2023 *E3S Web Conf.* **452**, 04008. <https://doi.org/10.1051/e3sconf/202345204008>
13. Xie Y, Liu X, Zhang C and Wang H 2022 *Fuel Process. Technol.* **316**, 123355.  
<https://doi.org/10.1016/j.fuel.2022.123355>
14. Arifjanov A and Kurbonov K 2023 *E3S Web Conf.* **452**, 04010.  
<https://doi.org/10.1051/e3sconf/202345204010>
15. Tan C K, Kakietek S, Wilcox S J, Ward J, Golec T and Szymczak J 2006 *J. Energy Inst.* **79**, 251–256. <https://doi.org/10.1179/174602206X152581>
16. Xodjiev N, Juraev Sh, Kurbanov K, Sulonov S, Axatov D and Babayev A 2022 *Analysis of the resource-saving method for calculating the heat balance of the*

- installation of hot-water heating boilers. Asia-pacific conference on applied mathematics and statistics, Chiangmai, Thailand, p. 020019.  
<https://doi.org/10.1063/5.0090455>
17. Arifjanov A, Babajanov F, Xoshimov S and Sultonov R 2024 BIO Web Conf. **105**, 05015. <https://doi.org/10.1051/bioconf/202410505015>
  18. Arifjanov A, Xodjiyev N, Jurayev S, Kurbanov K and Samiev L 2020. IOP Conf. Ser. Mater. Sci. Eng. **869**, 042019. <https://doi.org/10.1088/1757-899X/869/4/042019>
  19. Juraev S, Akramov A, Xoshimov S and Abdullayev M 2023 E3S Web of Conferences., **452**, 06014 <https://doi.org/10.1051/e3sconf/202345206014>
  20. Arifjanov A, Xoshimov S, Babajanov F, Matkaziyev D, Komilov S, 2024 E3S Web Conf. **538**, 01023. <https://doi.org/10.1051/e3sconf/202453801023>
  21. Madaliev, M., Usmonov, M., Umirzakov, Z., Usmonov, S., Ismoilov, M., Adilov, Z., & Alimova, N. (2024). E3S Web of Conferences (Vol. **538**, p. 01013). EDP Sciences.
  22. Madaliev, M., Usmonov, M., Soliyev, O., Otajonov, J., Kadirov, K., Otakhanova, Z., & Mavlonova, D. (2024). E3S Web of Conferences (Vol. **538**, p. 01018). EDP Sciences.
  23. Khujaev, P., Abdulkhaev, Z., Numonjonov, S., Karimov, N., & Akhunov, K. (2024). E3S Web of Conferences (Vol. **538**, p. 01010). EDP Sciences.
  24. Madraximov, M., Abdulkhaev, Z., Ibrokhimov, A., & Mirababaeva, S. (2024, June). In AIP Conference Proceedings (Vol. **3119**, No. 1). AIP Publishing.
  25. Khujaev, P., Ismatullozoda, J., Umirzakov, Z., Maxsitaliyev, B., Tillaboyeva, F., Sobirov, M., & Mamatov, A. (2024). E3S Web of Conferences (Vol. **538**, p. 01004).
  26. Khujaev, P., Bokiev, B., Kholmurotov, T., Murodov, P., Yakubov, A., & Said, M. T. (2024). E3S Web of Conferences (Vol. **538**, p. 03019). EDP Sciences.