

Methods and technical means of reducing power losses in 0.38 kV networks with a symmetering device

Ilyaz Turduev^{1*}, *Buazhar Kochkonbaeva*², and *Nuripa Abdyaeva*¹

¹Osh Technological University named after M.M. Adyshev, Osh city, 723503, Kyrgyzstan

²Osh State University, Osh city, 723500, Kyrgyzstan

Abstract. The relevance of this paper is due to the need to solve a specific problem, which is the reduction of power losses in asymmetrical electric receivers. The purpose of this paper is to develop methodological prerequisites for analyzing ways to reduce power losses caused by asymmetry of currents in a 0.38 kV network and to study the influence of current asymmetry on the increase of electrical losses, as well as to determine the effectiveness of symmetrical devices in reducing these losses. Among the methods used, we should mention the analytical method, classification method, functional method, statistical method, synthesis method and others. This paper highlights the issue of developing a methodology and theoretical studies, as well as conducting experimental studies on additional power losses caused by asymmetry of currents and voltages in 0.38 kV networks using symmetrical devices. The solution of problems of power supply and improvement of electric power quality in such low-voltage networks is closely connected with the problem of current asymmetry reduction. This study is of practical importance as it contributes new scientific knowledge and offers practical recommendations for effective improvement of low-voltage power networks.

1 Introduction

The study of this topic is necessary to increase the service life of power sources in networks with phase misalignment. In the presence of phase misalignments in the network there are current and voltage fluctuations, which leads to increased power losses. Symmetering devices used in electrical networks are able to reduce the amplitude of these fluctuations and resistance, which reduces power losses. Technical losses of electricity during its transmission through power grids are significant and include conditionally constant and conditionally variable losses. Calculation of these losses is carried out in accordance with the established methods. However, in the context of networks with phase skew, these techniques may not be sufficiently effective. The study of this topic will make it possible to study in more depth the mechanisms of occurrence and reduction of power losses in networks with phase skew. This, in turn, contributes to a more effective management of power losses and optimization of

* Corresponding author: ilyaz_turduev@mail.ru

power grids. The results of the study can be used to develop new technical solutions and methods aimed at reducing power losses and improving the efficiency of networks with phase misalignments.

The problematics of the research is the need to reduce power losses during transmission through electric networks, especially in the case of phase misalignment, as well as in the definition of effective methods and the use of symmetering devices. The research is aimed at analyzing technical losses in the lines and equipment of electrical networks, caused by physical processes, and developing a methodology for calculating losses in the transmission of electricity. The problem is to determine and reduce conditionally constant and conditionally variable losses, which will improve the efficiency of electric networks and increase the resource of energy sources.

According to B. Baetov, the development of export potential of the electric power industry of the Kyrgyz Republic is important for economic growth and energy independence of the country.

Electricity plays a key role in the development of various sectors of the economy, such as industry, agriculture and transportation. Increasing the export potential will allow Kyrgyzstan to actively participate in international energy trade and receive substantial revenues from electricity exports [1].

According to B. Barbiev, the analysis of renewable sources of electricity in the Kyrgyz Republic shows a significant potential for the development of this industry. Hydropower is the main source of renewable energy in the country due to the presence of rivers and mountain lakes. The potential of solar and wind energy is also significant. However, further research and investment is needed to identify optimal locations and scale up renewable energy projects. It is important to take into account environmental and social factors, and to ensure alignment with the energy needs and development strategy of the country. The development of renewable energy in Kyrgyzstan has the potential not only to provide a sustainable and clean energy sector, but also to attract investment, create jobs and reduce dependence on energy imports [2].

According to A. Matkerimov, the electric power industry plays a significant role in the economic growth of the Kyrgyz Republic, accounting for more than 16% of the EGP (External Gross Product) structure of the industry. It meets the energy needs of various sectors of production and the population of the country, as well as generates significant foreign exchange earnings from exports. Kyrgyzstan has total energy resources, including significant coal reserves and about 30% of the region's hydropower resources, of which only a small share has been developed to date. However, currently the republic still has to import more than 500 energy resources from neighboring countries [3].

K. Rakhimov notes that reducing technical losses of electricity in the Kyrgyz energy system is an important task to improve the efficiency and sustainability of the sector. Inefficiency of the existing infrastructure, including old transformers, wires and switching equipment, is the main cause of losses. To reduce losses, modernization and renewal of equipment, use of efficient transmission technologies, introduction of control and monitoring systems, and staff development are necessary. Active cooperation between energy companies and state authorities, regular maintenance and repair of equipment is also important.

Reducing losses will save energy, improve system operation and contribute to the development of the economy and improve the quality of life [4]. According to K. Saidov, methods of energy reduction of electric energy in power grids and electrical installations play an important role in improving energy efficiency and sustainability of power supply systems. They are aimed at reducing electricity consumption, optimizing the operation of equipment and networks, and implementing energy-saving practices [5].

The purpose of the study is to identify effective methods and recommendations for reducing current asymmetry and improving the energy efficiency of 0.38 kV networks.

2 Materials and methods

The analytical method, helped to highlight problem areas and identify sources of electrical energy losses. It assessed the energy efficiency of various systems and processes, identified inefficient practices and offered specific recommendations for their elimination. The statistical method was used to examine energy consumption, efficiency, and electrical energy losses in various systems and components of the electrical grid and electrical installations.

Data on energy consumption distribution, equipment operating time, load power and other parameters were collected and studied.

By applying the functional method, the characteristics and energy efficiency of power supply systems and electrical installations were studied. This method made it possible to determine the links between energy consumption, functioning and optimal operation of the system, and to identify the most energy-intensive processes and components.

The structural-functional method helped to systematize and study the structure of power supply systems and electrical installations. This method allowed us to study the interrelationships between system components, their functional dependencies and their influence on energy consumption.

The method of deduction helped in identifying the causes of electrical energy losses in the power supply system and electrical installations. It is based on logical reasoning and examination of available facts, data and principles.

By applying the synthesis method, solutions and measures to reduce electrical energy losses in the power supply system and electrical installations were developed. This method is based on combining and integrating different technical, organizational and management solutions.

The research was conducted using this equation, which describes the relationship between characteristic values (resistances or reactances) in a three-phase electrical system:

$$x_l = x_c = h_n \cdot 3\sqrt{3}; \quad x_c = x_n, \quad (1)$$

where x_l represents the inductive reactance of the choke, x_c represents the capacitive reactance of the capacitor bank, h_n represents the rated capacitance of the capacitor bank.

The theoretical component of the work was disclosed. It included the analysis of existing methods and technologies for reducing power losses, study of their operating principles, efficiency and limitations. Their applicability in the context of a particular power supply system was also assessed. Further, a selection of optimal methods and technologies for reducing power losses was carried out. Factors such as implementation cost, availability, technical complexity and projected loss reduction effect were considered.

Practical studies and experiments were conducted to assess the effectiveness of the selected methods of reducing power losses in real conditions of the power supply system and electrical installations. During the practical component of the work, the necessary measuring devices were installed and measurements of power consumption, voltage, current and other parameters were made in various parts of the system. The equipment and load were also monitored to obtain accurate data on the current status and efficiency of the system. The collected data was analyzed and compared with preliminary projections and expected results. The level of reduction in electrical energy losses, the energy efficiency of the system, as well as other indicators related to operation and stability of operation were assessed.

As a result, through a combination of theoretical analysis and practical research, specific recommendations and solutions for reducing electrical energy losses in the power supply system and electrical installations were obtained, which can be successfully implemented and lead to optimized energy consumption and improved system efficiency.

3 Results

0.38 kV power grids play an important role in the transmission and distribution of electricity from power plants to consumers. They represent the last link in the transmission chain and are essential for ensuring efficient and reliable power supply [6]. 0.38 kV networks account for approximately 40% of the total length of all electrical networks. This indicates the widespread use of such networks and their importance to the overall electricity infrastructure. The reliability of 0.38 kV networks and their utilization have a decisive impact on the reliability, quality and cost-effectiveness of electricity supply to consumers. Appropriate measures should be taken to ensure the continuity of operation of these grids and to maintain their optimal utilization. The accuracy of calculations of losses in 0.38 kV networks is also important. This makes it possible to identify and estimate commercial losses that may occur during the transmission of electricity through these networks. More accurate loss calculations allow for more effective control and management of power flow, which ultimately contributes to more efficient and cost-effective operation of power grids.

There is a problem associated with significant phase-to-phase voltage distortions in 0.38 kV networks [7]. On phases with high load the voltage is reduced to 200...208 V, while on less loaded phases due to "zero" offset it can reach 240 V and more. This can lead to failure of electrical appliances and consumer equipment due to increased voltage.

Voltage asymmetry occurs in line conductors due to phase current distortions caused by uneven distribution of single-phase loads. Different voltage drops lead to asymmetrical voltage, which manifests itself as a zero offset. As a result, with a four-wire line, a current equal to the geometric sum of phase currents occurs in the neutral wire [8]. When the load of one or two phases is disconnected, a current equal to the load phase current may flow through the neutral wire. In such cases, it is impossible to avoid additional losses in 0.38 kV networks. These losses are related to the current flowing through the neutral wire, which leads to irrational use of electrical energy and an increase in the total losses in the system. To solve this problem, appropriate measures such as load balancing, installation of compensation devices, control and regulation of voltages in the network are necessary. This will reduce voltage imbalances and minimize additional losses in 0.38 kV networks, ensuring more efficient and reliable power supply to consumers.

Operating modes of 0.38 kV networks are objectively asymmetrical. Studies have shown that in networks where there are municipal and mixed loads, there is a significant current asymmetry [9]. Current asymmetry leads to voltage asymmetry at the terminals of three-phase electric consumers, exceeding the permissible values by 2...2.5 times. This asymmetry of currents in the network has a negative impact on the electric power system. As a result of current asymmetry, voltage asymmetry occurs, which can lead to uneven operation of electrical appliances and equipment, as well as to their additional losses and wear. This is especially true for three-phase electric consumers, which cannot function optimally under such asymmetry. In addition, current asymmetry affects power losses in 0.38 kV lines and consumer transformer substations. At the value of reverse and zero sequence coefficients of currents in the network, equal to 25...30%, power losses increase by 30...50% compared to the symmetrical mode of operation.

Unsymmetrical mode of operation of 0.38 kV networks leads to power losses and reduction of system efficiency. To improve the situation and reduce current asymmetry in 0.38 kV networks, appropriate measures are required. This may include load balancing; installation of compensation devices and automatic voltage regulation means. Such measures will help to reduce current asymmetry, improve system performance and reduce energy losses.

Voltage imbalance in 0.38 kV networks can lead to significant errors in electricity metering. The accuracy of electricity consumption measurement may be reduced, which in

turn affects the accuracy of calculations and invoicing to consumers. Voltage asymmetry also has a negative impact on the operation of capacitor units, which are used for power factor correction [10]. The effect of voltage asymmetry also extends to the operation of the protection of electrical installations. Unbalanced voltages can lead to improper operation of protective devices, which increases the risk of damage to the equipment and the system as a whole. This creates potentially dangerous situations such as overloading or short circuits. When voltages are unbalanced, electric motors perform significantly worse compared to symmetrical operation.

Voltage asymmetry leads to uneven power distribution in phases and additional power losses [11]. This affects the thermal operation of electric motors as heat losses increase. The additional power losses lead to increased heating and can be one of the causes of thermal damage to the insulation. Premature aging of electric motor insulation shortens the life of the motor and may require repair or replacement of the equipment.

One of the causes of power losses in 0.38 kV networks is the presence of leakage currents. Leakage current occurs due to incomplete insulating resistance of electrical devices and conductors [12]. This leads to the passage of part of the electrical energy through the insulation and ground, which is accompanied by losses. Another cause of losses is load asymmetry in phases. Load asymmetry means that the power and current distribution between phases is not equal. This can be caused by various factors such as unequal connection of loads, improper phase balancing or the presence of unbalanced loads. Unbalanced loads result in additional energy losses in wires and transformers, which reduces the efficiency of power transmission. Another factor affecting power losses and power quality is the circulation of higher harmonic currents in the network. Higher harmonics are irregular oscillations that are present in an electrical system. They can be caused by non-linear loads such as electronic devices, electric drives, etc.

Circulating currents of higher harmonic components lead to additional energy losses and distortion of the voltage waveform, which can negatively affect the operation of electrical devices and systems.

In rural 0.38 kV distribution networks there is current asymmetry, which is caused by uneven distribution of single-phase loads over the network phases and random characteristics of their operation. Power and currents consumed on different phases are not equal. Unbalanced operation of these networks is a real phenomenon that requires special measures to reduce current asymmetry and power losses.

Non-uniformity of currents occurs due to unequal distribution of single-phase loads over the phases of the network. In rural areas, where different types of consumers such as households, farms, industrial facilities, etc. are usually present, the loads on the phases may not be uniform [13]. For example, one phase may have a heavy load due to the operation of agricultural equipment or industrial units, while other phases may be less loaded. Also, random characteristics of consumer operation, such as switching on and off of electrical equipment, can cause temporary fluctuations in power consumption in different phases. This also contributes to current asymmetry in 0.38 kV networks. To reduce current asymmetry and power losses in such networks, it is necessary to carry out special measures.

These may include load balancing, installation of compensation devices, redistribution of loads, as well as control and regulation of consumers. These measures help to achieve a more even distribution of loads and reduce current asymmetry, which in turn reduces power losses and increases the efficiency of the network.

Compared to other control systems (CS), the symmetering device is the simplest and includes the following components: load, additional capacitor bank, autotransformer, capacitor bank and choke. In this device, the autotransformer has a transformer ratio of 2. This means that the current flowing through the first winding is twice the current flowing through the second winding. This current ratio makes it possible to achieve the necessary

reactive power compensation. The reactive resistances of the device are determined by expressions (1).

According to equation (1), the inductive reactance of the choke and capacitive reactance of the capacitor bank are equal to the product of the nominal capacitance of the capacitor bank by $3\sqrt{3}$. Thus, the reactive resistances of the device are determined from the nominal capacitance of the capacitor bank. This expression allows determining the appropriate values of the reactive components in the device to achieve the required reactive power compensation.

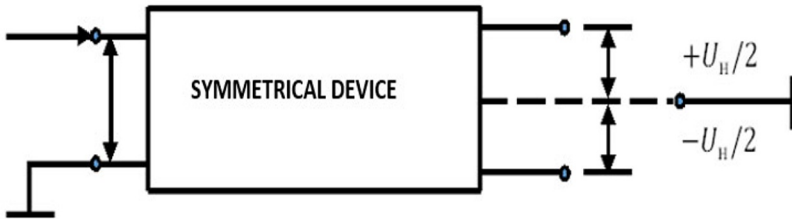

Fig. 1. Circuit diagram of the symmetrical device.

The main requirements for a symmetrizing device are:

- they must not impair the matching of the feeder with the load;
- they must not introduce losses into the feeder path, i.e. they must be made of reactive elements.

The symmetrizing device is designed to preserve the electrical symmetry of a symmetrical element when it is connected to an asymmetrical element and is switched on between them (Figure 1). The principle of operation of the locking type symmetrizing device is based on creation of high frequency isolation between the input terminals of the symmetrical element and the surface being at zero potential. When a symmetrical element is connected to an unsymmetrical system, various problems such as interference, signal distortion or signal loss due to potential mismatch may occur. A latching-type symmetry device is designed to prevent these problems and ensure consistent operation between the elements. The basic idea of a latching type symmetrical device is to create electrical isolation between the input terminals of a symmetrical element and the surrounding surface, which is at zero potential. This is achieved by using special insulating materials and design solutions. High-frequency isolation provides blocking of high-frequency signal or interference flows that may occur when a symmetrical element is connected to an asymmetrical system [15]. The zero potential surface plays the role of grounding or potential neutralization, which avoids the transfer of unwanted signals or flows to the symmetrical element.

Thus, the application of symmetrizing devices allows to avoid undesirable phenomena and their harmful effects arising at feeding of symmetrical vibrators by asymmetrical transmission lines. Significant reduction of electric energy losses caused by current asymmetry in rural 0,38 kV distribution networks with municipal and mixed loads can be achieved by applying methods and technical means that reduce the zero-sequence current of the network.

These include methods and technical means, reducing the asymmetry of loads, as well as the zero-sequence resistance of the load node with single-phase and asymmetrical three-phase electric consumers.

There are methods of calculation of current and voltage asymmetry indices in a 0,38 kV rural network with a symmetrizing device taking into account the power supply voltage asymmetry.

When determining the asymmetry indices of voltages and currents, the asymmetry of supply source voltages is not taken into account when using symmetrical devices. Three-phase asymmetrical load and symmetrical device have statistical character. Taking into account the adopted assumptions, let us depict the three-phase network substitution diagram (Figure 2.), which is made by the author on the basis of data [14]. Adopting the complex has a three-phase asymmetrical load by an asymmetrical voltage source. As a result of this substitution, the circuit under consideration becomes symmetrical, and therefore the differently symmetrical components of currents and voltages in it do not depend on each other.

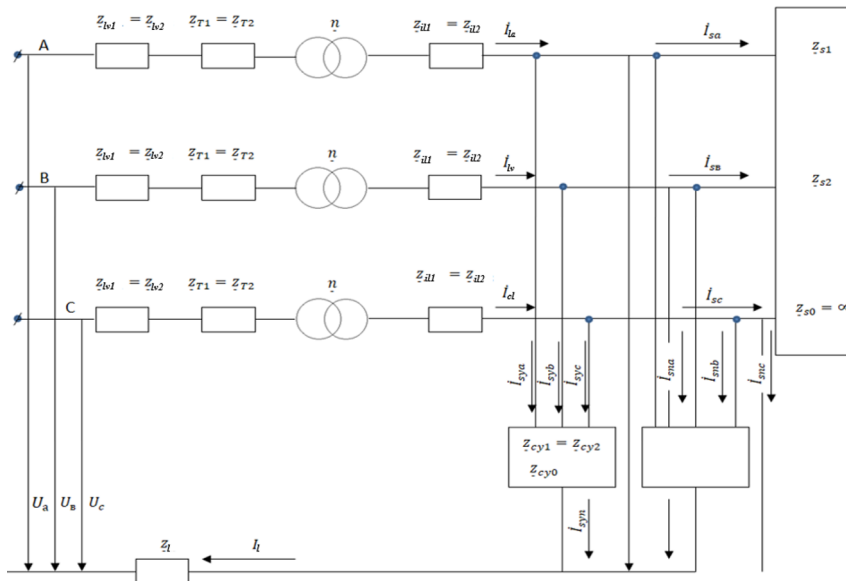

Fig. 2. Substitution diagram of the electrical network section with loads and symmetrizing device.

4 Discussion

In the course of research and analysis of the problem of electric energy losses in 0.38 kV networks, various methods and technical means that allow to reduce these losses have been identified. One of such means is a symmetrical device, which plays an important role in eliminating current asymmetry and improving the efficiency of power transmission.

A symmetrizing device consists of several components including load, additional capacitor bank, autotransformer, capacitor bank, choke and other elements. It is simple in structure, but it has significant advantages in eliminating current asymmetry and reducing power losses, improving the efficiency and reliability of the electrical system.

The use of a symmetrizing device allows the electrical symmetry of a symmetrical element to be maintained when it is connected to another element. It provides high frequency isolation between the input terminals of the symmetrical element and the zero-potential surface, minimizing noise, signal distortion and signal loss.

This ensures coordinated operation between the elements and improves the power transfer efficiency, contributing to stable and reliable system operation. The results of the study confirm that the symmetrizing device is an effective technical means to reduce electrical energy losses in 0.38 kV networks. It contributes to improving the operation of electric

motors, reducing the thermal mode, preventing premature aging of insulation and increasing the service life of equipment.

However, it should be noted that a symmetering device is only one of many possible ways and technical means to reduce power losses. Other methods, such as reactive power compensation, use of energy saving technologies, optimization of system operation modes and improvement of electrical equipment, can also be applied to achieve more efficient power transmission and increase energy efficiency.

Thus, the symmetering device is a significant technical means contributing to the reduction of electrical energy losses in 0.38 kV networks. However, in order to achieve maximum results, it is recommended to use a comprehensive approach that includes various methods and technical solutions adapted to specific conditions and requirements of the electric power system. This will effectively reduce power losses and improve the efficiency of 0.38 kV networks.

According to the results of recent research by D. Chembe, Reduction of power losses by phase alignment in electrical networks is an important aspect of energy efficiency and system optimization. This method aims to minimize the asymmetry of phase parameters such as voltage and current, which reduces power losses and improves transmission efficiency. One method of phase equalization involves the use of compensation devices such as capacitor banks. Capacitors can be connected in parallel to the load or at specific points in the system to compensate for reactive power and align the phases. This reduces power losses associated with reactive power and improves the electrical symmetry of the grid. Another method of reducing power losses by phase alignment is the use of autotransformers. Autotransformers allow to change the voltage and compensate for power losses by connecting different windings, which helps to balance the phases and reduce losses [15].

However, it should be considered that phase alignment methods may have limitations and may require additional costs for installation and maintenance of compensating devices or autotransformers. In addition, the effectiveness of such methods may depend on the specific conditions and requirements of the system. Therefore, it is important to analyze and select optimal solutions taking into account the specifics of a particular electrical network.

Turning to E. Babai's definition, a symmetering device plays an important role in reducing electrical energy losses and eliminating current asymmetry in electrical systems. Current asymmetry can occur due to various reasons such as unequal load, asymmetrical phase distribution in a three-phase system or unbalanced electrical parameters of equipment. When a network experiences current asymmetry, it can lead to uneven load distribution on wires and equipment, as well as increased electrical energy losses. A symmetrical device such as a symmetrical transformer or symmetrical autotransformer helps to reduce these problems [16].

Operating on the principle of electrical energy conversion, symmetrical devices ensure equal distribution of currents over phases in a three-phase system. They can be used to bring asymmetrical currents to a symmetrical state by correcting the amplitudes and phases of these currents. Researcher D. Wei determined that intrinsic polymer dielectrics are promising materials for electrical energy storage because they have high energy density and low losses. These materials can be used in high-energy capacitors, supercapacitors and electric batteries, allowing the creation of devices with large energy capacity and high efficiency [17].

In addition, the proprietary polymer dielectrics are flexible, chemically stable and easy to fabricate, which opens up new opportunities for the development of flexible energy sources.

M. Firmansia determined that the optimal placement of distributed generation is an important aspect of power systems in order to reduce power losses. One effective optimization method used for this purpose is Particle Swarm Optimization (PSO). PSO is based on modeling the behavior of a particle swarm, where each particle represents a potential generator location. The particles iteratively update their positions to optimize the

target function, which may include minimizing power loss or optimizing other parameters such as voltage or load degree [18].

This method finds optimal locations for generators to minimize power losses and improve the efficiency of distributed generation in the power system.

A. Salau showed by his work, Optimal network reconfiguration is an effective method to minimize power losses and improve voltage profile in distribution systems. This process involves reconfiguring the distribution network by opening or closing breakers and switches in order to optimize power flow and voltages. The objective of optimal reconfiguration is to achieve the lowest power losses and to ensure uniform and stable voltage in the system. Optimization techniques such as genetic algorithms, particle swarm algorithms or linear programming methods are applied to solve this problem [19].

These methods find the optimal network configuration by considering constraints such as transmission line capacity, maximum voltage values, and set breaker limits. Optimal network reconfiguration helps to improve the efficiency and reliability of distribution systems, as well as reduce energy losses and improve the voltage profile for more efficient operation of power grids.

As noted by A. Ogunjuyigbe, the introduction of distributed generators (DGs) in transmission sub-networks can significantly affect power losses and voltage profile. Distributed generators, such as solar panels or wind turbines, can provide power closer to the point of consumption, which reduces the need for long-distance transmission and reduces power losses on the grid. In addition, DGs can help maintain a stable voltage profile in transmission sub-grids. When DGs are connected to the grid, it is possible to increase the voltage at the endpoints, which can reduce power losses in transmission lines [20, 21].

However, it should be taken into account that improper placement or misconfiguration of DGs can lead to problems such as over voltages or under-voltages, which can negatively affect the efficiency and reliability of the network. Therefore, it is important to carry out system analysis and optimization prior to the implementation of DGs in order to achieve an optimal balance between reducing power losses, improving the voltage profile and ensuring reliable operation of transmission sub-networks.

5 Conclusion

In rural networks with voltage of 0.38 kV, current asymmetry plays a significant role in the increase of power losses. This is due to the uneven distribution of single-phase loads over the network phases and random characteristics of their operation. Unbalanced mode of operation of these networks is real and requires special measures to reduce current asymmetry and electric energy losses. To solve this problem, it is necessary to pay considerable attention to the development of methods and technical means to reduce asymmetry and power losses in rural 0.38 kV networks.

One of the possible solutions may be the use of specialized devices, such as symmetrical devices, which help to equalize current asymmetry and improve the efficiency of the network. In addition, regular monitoring and analysis of network conditions should be carried out to identify and eliminate causes of asymmetry and optimize system performance. It is important to note that reducing power losses in rural 0.38 kV networks require a comprehensive approach. Together with measures to reduce current asymmetry, it is necessary to take into account such factors as reactive power compensation, optimization of system operation modes, use of energy-saving technologies and equipment modernization. These measures together can significantly reduce power losses and improve the efficiency of rural 0.38 kV networks.

The inclusion of automatic control of asymmetry and balance of network currents is an important step in this direction. In addition to the aspects discussed above, further research

on this topic may include analyzing the impact of changing load parameters on current asymmetry and power losses, developing more accurate methods for determining asymmetry and evaluating the effectiveness of symmetry devices. It is also worth studying the effect of different types of distributed generators on current asymmetry and energy efficiency of the system. It is also important to conduct a comparative analysis of different technical solutions and identify optimal strategies for reducing power losses in different conditions of rural networks.

References

1. B.I. Bactov, B.K. Meimanov, A.V. Arkhangelskaya, *Bulletin of Economics, Law and Sociology* **4**, 21-24 (2017)
2. B.B. Barpiev, M.A. Sadykov, *Bulletin of the Kyrgyz State University of Construction, Transport and Architecture. N. Isanova* **3**, 98-101 (2016)
3. A.M. Matkerimova, *International Journal of Humanities and Natural Sciences* **4**, 127-130 (2017)
4. K.R. Rakhimov, *News of the Kyrgyz State Technical University. I. Razzakov* **3**, 98-101 (2020)
5. K.A. Saidov, *Science and innovative technologies* **16**, 101-111 (2020)
6. C. Han et al., *IEEE Communications Magazine* **49**, 46-54 (2011)
7. F. Lamberti, V. Calderaro, V. Galdi, G. Graditi, *Power Systems Research* **143**, 206-214 (2017)
8. L.S. Czarnecki, P.M. Haley, *IEEE Transactions on Power Delivery* **30**, 53-63 (2015)
9. K. Ma, L. Fang, W. Kong, *CSEE Journal of Power and Energy Systems* **6**, 479-488 (2020)
10. R.A.A. Mahmoud, A. Emam, *The Journal of Engineering* **5**, 512 (2022)
11. W. Alabri, D. Jayaweera, *IET Gener. Transm. Distrib* **16**, 2399-2415 (2022)
12. Yung-Ping Wu, Hsing-I Hsiang, *Materials Science and Engineering: B* **275** (2022)
13. Y. Zhang, H. Long, Y. Li, S. Tu, T. Jiang, *Journal of Rural Studies* **83**, 165-176 (2021)
14. I.E. Turduev, I.M. Zhusupov, *Bulletin of the Osh Technological University* **1**, 109-115 (2019)
15. D.A. Hewitt, S. Sundeep, J. Wang, A. Griffio, *IEEE Transactions on Industrial Electronics* **71**, 1432-1442 (2024)
16. D.K. Chembe, In *Proceedings of the World Congress of Engineering and Computer Science* **1**, 20-22 (2009)
17. E. Babai, M.F. Kangarlu, F.N. Mazgar, *Power Systems Research* **86**, 22-130 (2012)
18. J. Wei, L. Zhu, *Progress in Polymer Science* **106** (2020)
19. M.G. Firmansyah et al., *IOP Conf. Ser.: Mater. Sci. Eng.* **850** 012010 (2019)
20. A.O. Salau, Y.V. Gebru, D. Bityu, *Helion* **6** (2020)
21. A.S. Ogunjuyigbe, T.R. Ayodele, O.O. Akinola, *Journal of Electrical Systems and Information Technology* **3**, 94-107 (2016)