

# Interaction of logistic and production systems of the petrochemical industry in the conditions of industry 4.0

*Alexey I. Shinkevich*<sup>1</sup>, *Maria E. Nadezhdina*<sup>2\*</sup>, and *Sergei A. Solovlev*<sup>2</sup>

<sup>1</sup>Kazan National Research Technological University, 68, Karl Marks str., 420015, Kazan, Russia

<sup>2</sup>Kazan State Power Engineering University, 51, Krasnoselskaya str., 420066, Kazan, Russia

**Abstract.** The article is devoted to the actualization of information systems and technologies from the point of view of logistics and production processes of petrochemical enterprises. The topic is relevant in the context of the fourth industrial revolution and the transition to a new technological order, and is also confirmed by state development and digitalization programs. Logistic processes at petrochemical enterprises are closely linked with the production cycle. The study examines logistics and production processes in the aspect of industrial digitalization.

## 1 Introduction

World industry is in the active phase of the fourth industrial revolution. Understanding the fourth industrial revolution is based on the concept of Industry 4.0. A number of countries are implementing initiatives and programs aimed at developing advanced manufacturing technologies in the world. The functionality of industrial logistics is being transformed in accordance with the digitalization of the enterprise's macroenvironment. The study examines the tools of Industry 4.0 that contribute to productivity growth and cost minimization in all links of the value chain.

Turning to the global experience of digitalization, a number of initiatives and programs aimed at the development of advanced production technologies in the world are highlighted. Germany implements the Fraunhofer Program and Industrie 4.0. The first is aimed at the development of research activities in the industrial sector, the second, accordingly, stimulates the transition to cyber-physical systems of the Central Innovation Program and involves the allocation of grants to medium and small enterprises to finance research activities and innovative projects. In 2011, within the framework of the High-Tech Strategy 2020 plan, the German government initiated the Industry 4.0 project, which is based on the course of creating cyber-physical systems capable of solving any production problems, where today the monotonous labor of workers [carpenters] is used.

A concept similar to the German Fraunhofer program: support for 71 clusters in key technological areas, is being developed in France and is called Competitiveness Clusters. Australia is promoting collaboration between academic, government and industry research

---

\* Corresponding author: [frida333@mail.ru](mailto:frida333@mail.ru)

organizations to commercialize innovation through the Industry and Innovation Program. Japan has developed and is implementing the promotion of energy research and manufacturing technology under the New Energy and Industrial Technology Development Organization program. The Society 5.0 initiative is also being implemented, designed to solve social problems through the integration of physical and cyberspace. China is developing the high-tech industry sector according to the Made in China 2025 program.

Competencies in the field of IT have become a topical trend in logistics management. The reliability of the digital direction of the development of logistics management of an industrial enterprise is confirmed by a number of government initiatives and programs, development strategies and roadmaps. Since 2014, the National Technological Initiative (NTI, Technet) has been operating in Russia with the aim of introducing advanced production technologies into the industry. In May 2017, a decree was issued on the Strategy for the Development of the Information Society in the Russian Federation for 2017–2030. The program "Digital Economy of the Russian Federation" was approved by the government of the Russian Federation in July 2017.

Currently, you can already see the effect of the COVID-19 epidemic in the economy. According to RBC market research from August 2020, logistics companies recorded both a drop in revenue and its growth. The decline was recorded by 14% of the surveyed logistics operators, 43% of the enterprises participating in the survey noted an increase in revenue during the epidemic. The main factor that influenced the activities of industrial logistics 73% of respondents indicated the depreciation of the ruble. In the context of restrictive measures and specific movement of employees due to COVID-19, logistics companies with experience and developing Internet retail functioned effectively. As the real experience of the epidemic shows, IT occupies a leading place in the development of society, industry, state, etc.

The issues of using industry 4.0 tools in the management of logistics and production systems of the petrochemical industry are considered by foreign and domestic authors. Petrochemical enterprises have several strategic development guidelines. Strategic management of logistics activities and organization of petrochemical production is a driver of digitalization and actualization of the use of industry 4.0 tools. Management strategies at a petrochemical enterprise in the field of innovation, a closed cycle and lean organizational structures are analyzed in detail in the works [1-3]. Digital management strategy in their scientific works were considered in [4, 5]. Energy efficiency, environmental friendliness and resource efficiency of production systems are important metrics for the effectiveness of strategic management at a petrochemical enterprise. Energy efficiency indicators in assessing the petrochemical cluster were studied in the work [6]. The issues of energy consumption and resource efficiency of chemical-technological systems are considered in the works [7-10]. The issues of the functioning of the ecological sphere of petrochemical industries are considered in [11, 12]. The authors [13] considered the reserves for increasing the efficiency of petrochemical production using industry 4.0 tools. Evaluated the readiness of industrial production for digitalization [14]. The problems of computer modeling of chemical processes were studied in [15]. The authors [16] studied the design of technological systems for the chemical and petrochemical industry. Production planning and production management in ERP are considered in the works [17, 18]. Prospects for the use of virtual technologies in modern corporate business systems are considered in the article [19]. A more detailed discussion of logistic functions using big data to detect a logistic trajectory based on production data using RFID is considered in [20].

## **2 Materials and methods**

To substantiate the provisions put forward in the article, such general scientific research methods were used as a systematic approach, analysis and synthesis, induction and deduction, and analogy.

The greatest effect of digital transformation is achieved in the functional area of sales logistics. The functional area of procurement logistics is less susceptible to an increase in efficiency with the use of digitalization tools. However, the logistics system of a petrochemical enterprise is important to consider in conjunction with production cycles. In this article we propose to rely on the classification of the digital maturity of a production system (Fig. 1).



**Fig. 1.** Strategies for the technological development of production in the conditions of the 4th industrial revolution.

The use of digitalization tools increases the added value of products. According to the research of the global expert group Digital McKinsey, eight levers of influence on the management of the value added chain can be distinguished: optimal operating modes of capacities, optimal equipment utilization, growth of safety and labor productivity, optimization of logistics functions, improvement of product quality, growth efficiency of demand forecasts, reduction of time to market a product, improvement of after-sales service [9].

### 3 Results

The digital transformation and sustainable development focus in the chemical industry is driving a change in the vision of the functional areas of logistics. Sustainable development presupposes the formation of a circular economy. This is especially important in the chemical industry, as it reveals the possibilities of using re-use of recyclable materials, as well as energy saving technologies during the production of chemical and petrochemical products. Current trends pay attention to the development of the methodological base of reverse logistics. Figure 2 shows information systems distributed according to the level of the product production life cycle. One of the most well-known information technologies that can be attributed to business digitalization tools, and suitable for the concepts of reverse logistics and circular economy, is PLM (Product Lifecycle Management). This concept originated in discrete industries, but current trends in the chemical industry have made it important to develop PLM applications.

The use of information technology in logistics systems has become more integrated in the context of digital transformation. At the beginning of the new millennium, the use of

information technology was of a point nature, for example, WMS systems were used in warehouse logistics, and an SRM system was used in procurement logistics. Digital transformation entails the creation of common information spaces, both at the level of logistics systems and business, and at the level of supply chains, and chain management is virtualized, ecosystems appear.

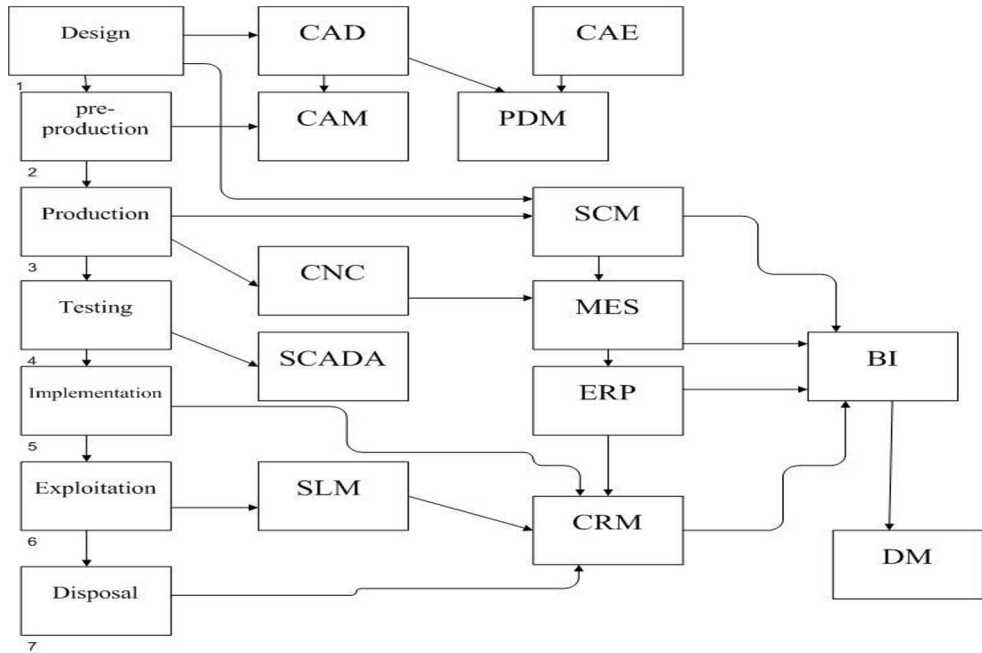

**Fig. 2.** Digital information ecosystem modules

The strategic management of the organization of production and logistics involves the interaction of many subsystems of the enterprise and, therefore, the strategies of the structural divisions are coordinated and contribute to the achievement of the global goal of the enterprise. About 50% of petrochemical and chemical enterprises do not have a digital transformation strategy. The petrochemical enterprise operates in a diverse ecosystem and develops in accordance with current global trends. We propose to use a decomposition of processes for managing the digital transformation of a manufacturing enterprise (Fig. 3).

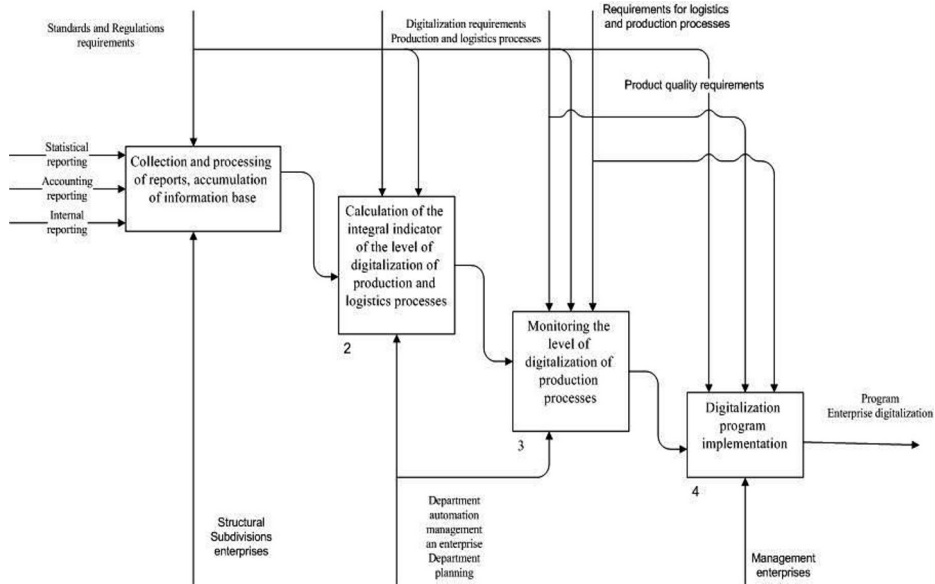

**Fig. 3.** Decomposition of processes for effective digital transformation in an enterprise.

The information system is formed on the basis of statistical, accounting and internal reporting data. The use of this data will make it possible to implement the digitalization strategy of the enterprise's production processes, as well as the revision and engineering of the measures taken. An information system for monitoring the level of digitalization of production processes will increase the level of organization of production, increase labor productivity and reduce production losses.

The monitoring system consists of:

- hardware complex of measuring, telecommunication equipment, which is installed on the controlled object;
- a software aggregator that collects all data coming from the hardware complex;
- dispatching software complex for continuous monitoring of the state of the controlled object;
- a predictive analytics software package that analyzes data coming from the aggregator and forms a set of recommendations.

The enterprise budgeting plan allocates a separate economic estimate to the information technology center [7]. The Information Technology Center occupies a separate niche in the management structure of the enterprise and constitutes the organizational structure of the unit. The mission of the division is to ensure uninterrupted support of information and technological resources at all stages of the production life cycle and after-sales service of products and services.

## 4 Discussion

Many factories have a very worn-out production capacity of about 70-80%. The high degree of wear and tear of production facilities causes frequent downtime of equipment due to unplanned breakdowns of machines and machines, and repair work is often delayed and does not provide an opportunity for uninterrupted production in the future. Of course, this fact affects the competitiveness of petrochemical and chemical enterprises at the Russian and state levels. Unbalanced production capacities, a high share of non-core assets significantly

reduce the efficiency of organizing the production of enterprises in the petrochemical and chemical industries.

It should be noted that the age of capacities in chemical production is generally an insignificant criterion for the effectiveness of the organization of production processes. There is a large proportion of obsolete facilities at the same level as modern equipment. This state of affairs is observed in the industries of fertilizers, rubber and polymer production. However, a number of chemical industries have a low level of competitiveness of production facilities. These are industries for the production of capacities, detergents, paints and varnishes, etc. But let us note the low volumes of final products in the scale of the Russian chemical industry.

## 5 Conclusion

Petrochemical enterprises are characterized by outdated capacities, complexity of the production cycle, and a variety of logistics operations. However, with all the above factors, petrochemical enterprises are catching up with the digital maturity of the Russian industry and are showing high activity in digital transformation. Logistics cycles are closely intertwined with production cycles and must match the digital environment of petrochemical production in order to fulfill the enterprise's global purpose. In the article, we examined information technologies and systems for organizing information space for the functioning of petrochemical production and logistics. We consider it expedient to smooth digital transformation of a petrochemical enterprise through point digitalization of processes. We note the importance of a systematic vision of production and logistics processes and taking into account the interconnections of digitized areas.

## References

1. N.V. Barsegyan, S.S. Kudryavtseva, L.N. Ivanova, IOP Conf. Ser.: Materials Sci Eng. **919**, 052044 (2020)
2. N.V. Barsegyan, I.G. Salimyanova, E.R. Kushaeva, J. Phys.: Conf. Ser. 1515, 042090 (2020)
3. F. Blomsma, M. Pieroni, M. Kravchenko, D.J. Pigosso, Clean. Prod. **241**, 118271 (2019)
4. V.P. Meshalkin, S.M. Khodchenko, V.I. Bobkov, M.I. Dli, Dokl. Chem. **475**(2), 188 (2017)
5. M.S. Reis, P.M. Saraiva, Syst. Eng. Fourth Ind. Rev. 137 (2019)
6. A.N. Dyrdonova, T.S. Lin'kova, E3S Web Conf. **124**, 04013 (2019)
7. A.I. Shinkevich, T.V. Malysheva, Y.V. Vertakova, V.A. Plotnikov, Mathematics. **9**(4), 322 (2021)
8. J. Patterson, O. Widerberg, K. Schulz, M. Sethi, A. Barau, Env. Innov. Soc. Trans. **24**, 1 (2017)
9. V.G. Antonov, M.V. Samosudov, E-Management. **2**, 38 (2018)
10. Y. Lin, Chem. Eng. Trans.. **65**, 475 (2018)
11. V.P. Meshalkin, V.I. Bobkov, M. Dli, Theor. Found. Chem. Eng. **53**(6), 960 (2019)
12. K.A. Artamonova, O.Y. Gavel, D.S. Lopatkin, L.E. Kopylova, O.M. Aliev, A.A. Gibadullin, J. Phys.: Conf. Ser. **1515**(3), 032004 (2020)
13. B.B. Bogomolov, V.S. Boldyrev, A.M. Zubarev, V.P. Meshalkin, V.V. Men'shikov, Theor. Found. Chem. Eng. **53** (5), 709 (2019)

14. G.V. Butkovskaya, E.V. Sumarokova, *E-manag.* **1515**, 032004. (2019)
15. R.Y. Zhong, G.Q. Huang, S.L. Dai, D.X. Chen, T. Zhang, *Int. J. Prod. Econ.* **165**, 260 (2015)
16. E. Klochko, O. Brizhak, *Adv. Intelligent Syst. Comp.* **726**, 308 (2019)
17. P. Samaranyake, T. Laosirihonghong, *Int. J. Manag. Sci. Eng. Manag.* **10(3)**, 176 (2015)
18. A.A. Lubnina, F.F. Galimulina, G.R. Garipova, V.V. Bronskaya, O.S. Kharitonova, *J. Phys.: Conf. Ser.* **1399(3)**, 033091 (2019)
19. A.I. Shinkevich, N.V. Barsegyan, M.V. Shinkevich, S.S. Ostanina, F.F. Galimulina, M.E. Nadezhdina, *E3S Web Conf.* **124**, 04006 (2019)
20. A. Makarova, N. Tarasova, I. Kukushkin, E. Reshetova, V. Meshalkin, E. Kudryavtseva, R. Kantukov, *Int. J. Qual. Res.* **12(1)**, 43 (2018)