

The technology of improving the drying process of cotton raw materials in a drum dryer

Abdugaffor Khurmamatov¹, Elmurod Umarov^{2,*}, Shukhrat Matkarimov², and Bobur Tojiboyev²

¹Academy of Sciences of the Republic of Uzbekistan, Institute of General and Inorganic Chemistry, Tashkent, Uzbekistan

²Fergana Polytechnic Institute, Fergana, Uzbekistan

Abstract: The most important factor in maintaining quality during cotton processing is to significantly reduce moisture content. Therefore, in order to improve the drying process of cotton raw materials, a test model of a drum drying device was created in the Laboratory of Chemical Technology Processes and Devices of the Institute of General and Inorganic Chemistry of the Academy of Sciences of the Republic of Uzbekistan. In this device, the experimental process was carried out in a drying drum with a length of 2 meters. It was studied that the normal movement of the product depends on its inclination angle \angle and the number of rotations n . Graphs were made based on the obtained results. It was observed that the heat supplied to the raw material is uniformly distributed along the length of the device, so the loss of moisture is also uniform. It was observed during the experiment that the air temperature inside the drum was 70... 120 °C. An attempt was made to clarify these indicators on the basis of tables and graphs. We were convinced of this during the drying process of seed cotton in the experimental device. It was stated that the angle of inclination of our recommended drying drum is $\angle 6^\circ$ and its number of rotations is $n=12$ rot/min. **Key words:** Cotton, humidity, drying process, laboratory, drum drying, experimental test, model, angle of inclination, number of rotations, heat, air temperature, graph, research, fiber, average humidity, strong.

1 Introduction

The most important factor in maintaining quality during cotton processing is to significantly reduce moisture content. At higher humidity levels, cotton fibers are stronger [1], but the cleaning process becomes more complicated and the efficiency of cleaning equipment decreases. Therefore, it is important to know the standards of moisture level when cleaning and storing cotton [2].

The moisture in the atmosphere affects to many properties of cotton. If we take into account the presence of hydrophilic property in cotton fibers, it absorbs environmental moisture [3-8]. This greatly affects to the quality of the fiber. In the research work, it was determined that the average moisture content of cotton fiber is maintained from 5 to 20%,

* Corresponding author: e.umarov@ferpi.uz

and it is recommended to dry it before processing. Cotton moisture during the drying process makes it very difficult to clean the fibers from contamination, and this indicator affects the quality of the cotton fiber.

Normal cotton in most conditions should have a moisture content of 5½% to 6½%

Drying of cotton is a scientifically complex process, heat and matter exchange processes are carried out together [6,7]. Knowledge of the effect of changes in various indicators of cotton raw materials on the drying process is the basis of scientific research in this regard.

Taking into account the above, a test model of a drum drying device was created in the laboratory "Chemical technology processes and devices" of the Institute of General and Inorganic Chemistry of the Academy of Sciences of the Republic of Uzbekistan (Fig. 1) [4].

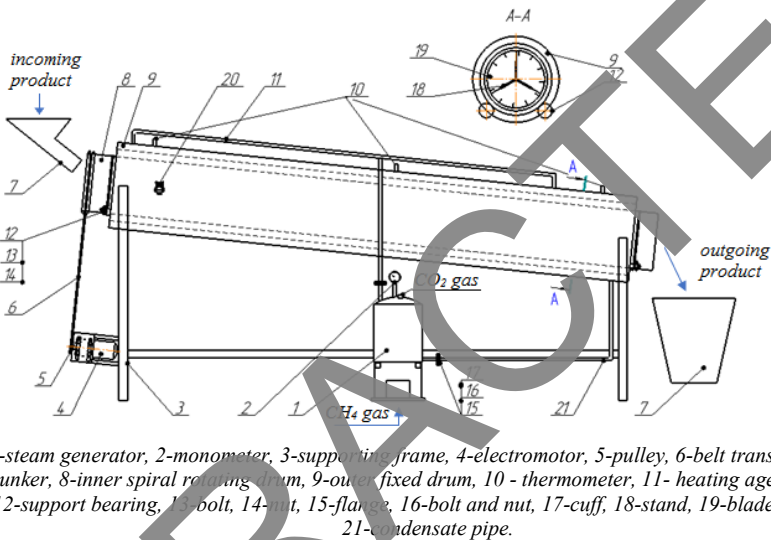

Fig. 1. The principle scheme of the experiment-test device of cotton drying with a drum

Drum cotton drying experimental device works as follows:

- one of the main parts of the drying drum consists of a hopper 7 that supplies raw materials and receives the product, an external fixed drum 9 and an internal spherical rotating drum 8 attached to it through support bearings 12, bolts 13 and nuts 14. The cotton raw material is regularly conveyed to the roller drum 8 through the hopper 7. Rotational motion is transmitted from the electric motor 4 to the roller-shaped rotating drum through a belt drive. The outer fixed drum 9 and the rolling drum are placed on the base frame 3 with an angle of inclination $\alpha=6^{\circ}$.

The shovels 19 shown in A-A of Figure-1 help advance the raw material. In addition, the main function of the shovel 19 and the tripod 18 is to increase the contact surface with the heat flow coming out of the internal spherical rotating drum through the heating agent (steam) 11.

The steam released from the steam generator 1 is sent to the external fixed drum [5-12]. The heat entering through the slits of the inner spherical rotating drum occupies the entire volume of the drum. In this case, the temperature and pressure inside the drum are controlled by thermometer 10 and manometer 2. If excess steam pressure occurs in the external fixed drum, it is discharged through the valve 20. In turn, the hot air inside the drum comes out together with the product after coming into contact with moisture.

In turn, the condensation process takes place in shell 9. Condensate is collected at the bottom of the shell and is redirected to the steam generator through pipe 21. The condensate pipe is fixed to the steam generator through a flange 15 [9].

2 Method of research

2.1 Studying the influence of different factors on drying raw cotton

Proper organization of the drying process will preserve the characteristics of the cotton raw material being dried, and even improve it. Therefore, the effect of the physical-thermophysical properties of the cotton raw material being dried and the parameters of the technological regime in increasing the efficiency of the drying process is studied.

The drying process consists of interrelated and simultaneous complex processes, which include the transfer of heat from the drying agent to the material and the transfer of moisture from it to the drying agent. Heat and moisture exchange depends on the surface of the material and the environment. Accordingly, the amount of heat supplied to the raw material, the number of rotations of the drying drum, its angle of inclination, the period of dividing the product and similar parameters have their effect. Below we will consider several factors that affect the drying process.

Effect of drying mode. The mode of drying with heated air is characterized by three indicators: air moisture content (d), its movement speed (v) and temperature (t). These indicators affect the duration of the drying process and the quality of the dried material. Therefore, it is necessary to choose a drying mode that achieves the best technological properties of the material while consuming less heat in the shortest drying time. Drying of raw cotton in drying equipment is carried out in a variable mode, that is, the moisture content of the drying agent increases, and the temperature decreases due to the moisture evaporating from the raw cotton [6,7].

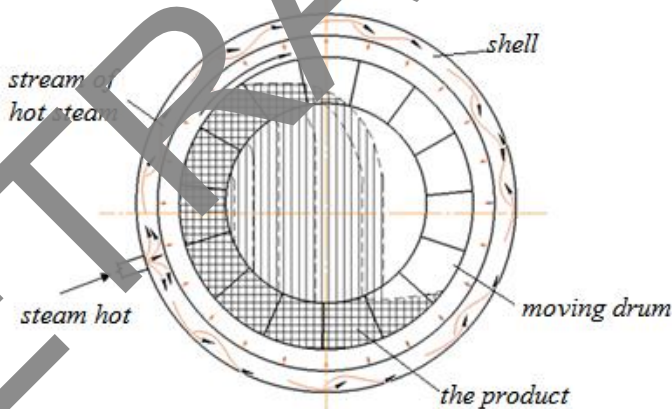

Fig. 2. The movement of heat applied to the drum to dry the raw material

3 Results

From Figure 2, it can be said that the hot steam stream supplied to the drum is uniformly distributed along the drum shell. The heat supplied to the shell is supplied at an angle. This was chosen based on experience. The raw material inside the device occupies a certain surface of the drum [3]. So, raw material receives the heat needed for moisture loss from the part touching the drum. The heat supplied to the drum is distributed over the entire surface and length at the same time. As a result of experiments carried out in a dryer in laboratory conditions, technological indicators of heat treatment of cotton are presented in Table 1. In

the table, the initial moisture content of seed cotton is given in percent, and we have achieved the result that we expected in a certain amount at the given temperatures for drying it.

Table 1. Technological indicators of heat treatment of seed cotton in an experimental device

Initial moisture content of cotton, %	Moisture loss, %	Temperature, °C
8... 9	1... 2	<70
10... 12	3... 4	70... 90
12... 14	4... 5	90... 95
14... 15	5... 6.5	95... 100
16<	7... 10	100... 120

In the process of drying wet cotton in the device, the flow of hot air coming out of the shell is uniformly distributed along the entire length of the roller drum. It was observed during the experiment that the air temperature inside the drum was 70... 120 °C. The main indicators of the experiments conducted in the experimental device are presented in Table 2.

Table 2. Key indicators of the experiments carried out on the experimental device

Key indicators	Experiments					Average
	1	2	3	4	5	
Time of exit of the initial product from the drum, min	1.12	1.22	1.25	1.31	1.32	1.24
Last product falling from the drum, min	7.2	7.58	7.55	8.57	9.12	7.96
The time of the raw material in the drum, min	6.07	6.56	6.29	7.05	7.4	6.63
Surface temperature at the beginning of the drum interior, t °C	83	80	81	79	80	80.6
Surface temperature in the middle of the drum, t °C	80	84	85	83	85	85.4
Surface temperature at the end of the drum interior, t °C	74	67	64	65	65	67
Pressure in the boiler, kPa	75	75	75	75	75	75
Point-in thermometer indicator on the drum, t °C	109	109	109	109	108	108.8
The number of rotations of the drum, rot/min	12	12	12	12	12	12
The temperature of the air inside the drum is i, t °C	70	66	65	65	66	66.4
Drum deviation angle, α °	6	6	6	6	6	6

We can see from the table that the initial and final output time t of the raw material sent to the device and the differences between them are shown. At the same time, general information is given about the temperature of the drum in different places t , °C, pressure in the steam generator P , (kPa), number of rotations of the drum n , (rot/min) and its angle of inclination α °.

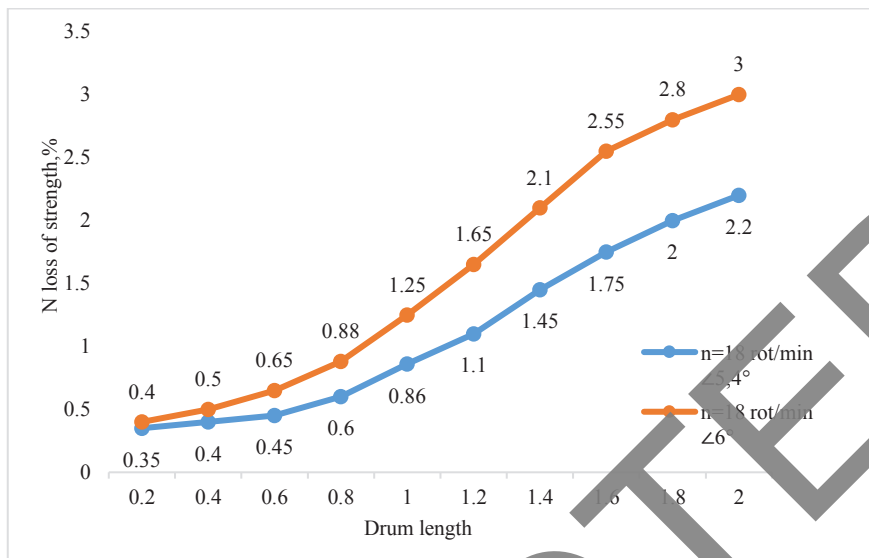

Fig. 3. Effect of changing drum tilt angle on moisture loss (n=18 rot/min).

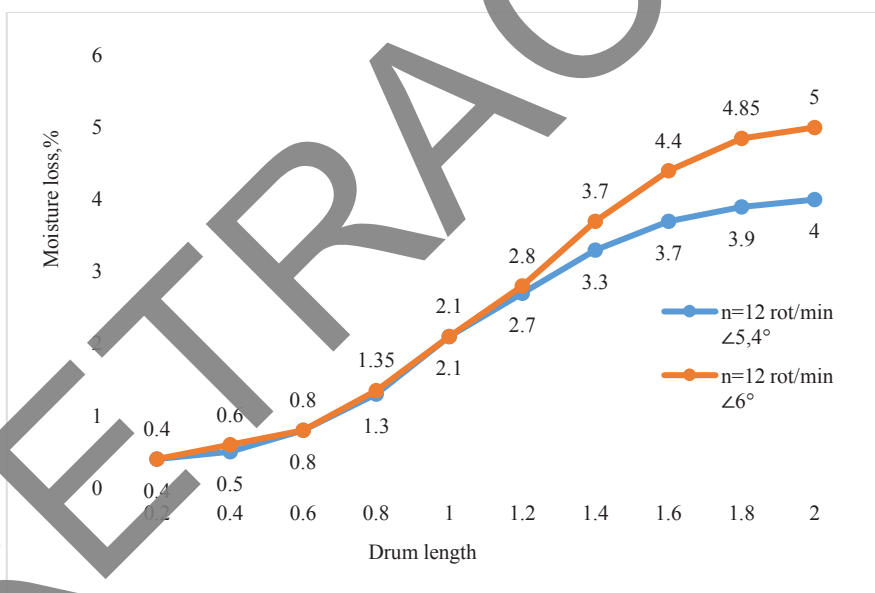

Fig. 4. Effect of change of drum inclination angle on moisture loss (n=12 rot/min)

The results obtained in the experiments were analyzed and graphs were created. Another parameter of moisture loss in cotton in drying drums is its slope angle. In the course of the experiment, it was studied the dependence of the product movement in the drying drum with a length of 2 meters on the slope angle. Graphs were made based on the obtained results (pictures 3-4). In the initial experiments, the number of rotations of the drying drum n=12 rot/min, the slope angle $\angle 5.4^\circ$, and the temperature was set in the range of 70...75 °C. It was observed that since the heat to the raw material is uniformly distributed along the length of the device, the loss of moisture is uniform [9,10,11,12].

4 Discussion

In subsequent experiments, the angle of inclination of the drum was changed to $\angle 6^\circ$ without changing the number of rotations of the drum. It can be seen that the difference occurs when the moisture loss of the product is 0.8 1 %. Analyzing the results of the experiment, it can be concluded that the optimal value of the angle of inclination of the drum and the number of rotations for drying seeded cotton in the experimental device should be set to $\angle 6^\circ$ and $n=12$ rot/min.

The time of the product in the drum is one of the main parameters in the cotton drying process. Taking this into account, the results of the experiment are presented in Tables 3-4.

Table 3. Results of the experiment to determine the time of the raw material in the drum

Parameters name	1	2	3	4
Weight of the product at the entrance, kg	1	1.1	1.3	1.4
Drum deviation angle, \angle°	5.4	6	5.4	6
Number of rotations, rot/min	8	12	12	18
Time of exiting the product from the drum, min.	1.09	1.24	1.36	0.88
The last product from the drum, min.	7.49	7.96	8.27	4.39
The time of the raw material in the drum, min,	6.33	6.63	6.63	3.37

Table 4. The experimental table of the effect of the number of rotations of the device and the angle of inclination on the period of division of raw materials

Number of rotations, rot/min	Angle of inclination, \angle°	Time of initial release of raw materials, min		The time of the raw material in the drum, min	
		min	avg	min	avg
12	4.33	2.06	1.46 avg	5.44	6.53 avg
		1.30		7.05	
		1.01		7.093	
	5.4	1.29	1.31 avg	4.20	4.27 avg
		1.42		5.05	
		1.32		3.57	
6.00	1.02	0.86 avg	4.10	4.25 avg	
	1.02		4.32		
	0.55		4.34		
18	4.33	0.59	0.73 avg	3.47	3.68 avg
		0.54		3.53	
		1.05		4.03	
	5.4	0.53	0.50 avg	3.21	3.24 avg
		0.52		3.19	
		0.44		3.32	
6.00	0.49	0.45 avg	2.42	2.67 avg	
	0.48		3.01		
	0.39		2.58		
20	4.33	0.51	0.65 avg	3.45	3.47 avg
		1.02		3.48	
		0.43		3.47	
	5.4	0.39	0.46 avg	2.56	2.57 avg
		0.56		2.57	
		0.44		2.58	
6.00	0.47	0.47 avg	2.24	2.30 a.m	
	0.45		2.32		
	0.49		2.34		

The number of rotations of the drum during cotton drying has a great influence on the drying efficiency. The effect of changing the number of rotations of the drum in the experimental device on the loss of moisture was studied and graphs were formed (Fig. 5).

In graphs we can see moisture loss increases along the length of the drum. The obtained results show that the efficiency of the cotton drying process is high when the inclination angle is $\angle 6^\circ$ and the number of rotations is $n=12$ rot/min [11-21].

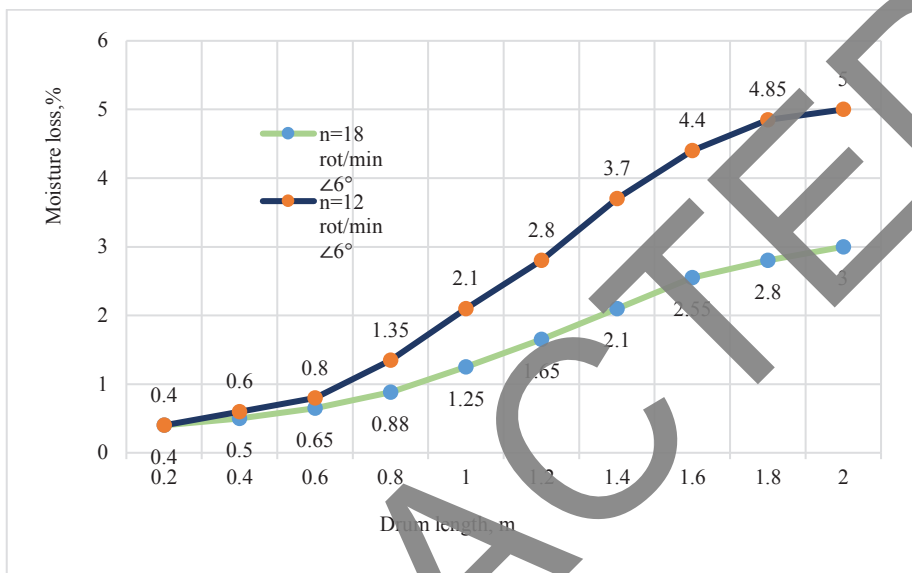

Fig. 5. The effect of changing the number of drum rotations on moisture loss ($\angle 6^\circ$)

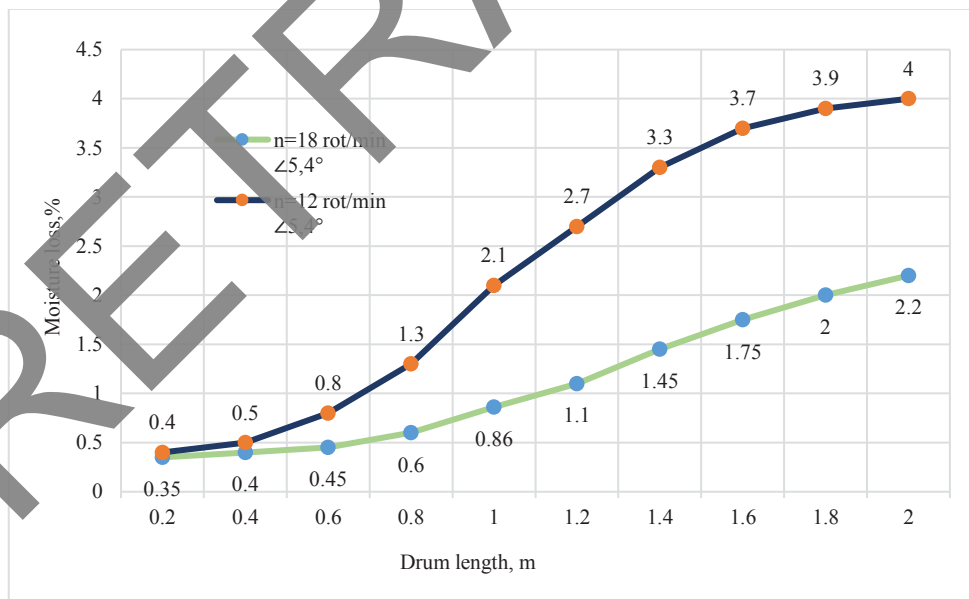

Fig. 6. The effect of changing the number of drum rotations on moisture loss ($\angle 5.4^\circ$)

5 Conclusion

In conclusion, it is possible to say that. During the process of drying seeded cotton in the experimental device, we were convinced that we decided to take our recommended drying drum with an inclination angle of $\angle 6^\circ$ and its number of rotations as $n=12$ rot/min.

References

1. Khamzaev, I.Kh., Umarov, E.S. (2022). Material resistance. "Classic" publishing house-2021, 360.
2. A. Parpiev. "Drying of raw cotton". T.: "Cholpon"-2009.
3. Khamzaev, I.Kh., Umarov, E.S. (2020). Journal of Engineering Research, **3(1)**
4. Nabiev, T.S., Umarov, E.S. (2021). About the operation of a cotton drum dryer. In Society-Science-Innovation (pp. 38-42).
5. Khamzaev, I.Kh., Umarov, E.S. (2015). Scientific and technical j. FerPI **19(2)**, 61.
6. Umarov, E.S. (2021). Scientific progress, **2 (7)**, 578-585.
7. Khamzaev, I.Kh., Umarov, E.S. (2022). *Thermal conductivity problem for a piecewise homogeneous plate with heat transfer through the base*. Online Journal of Sustainability and Leadership Studies, 245-249.
8. Nabiev T.S., Urimbaev O.K. J. International Journal of Experimental Education, M., 2011, **No. 6**, p. 79-81.
9. Umarov, E.S. Khurmamatov, A.M. (2022). Improving the process of drying in a drum oven. "Innovative technologies for processing mineral and technogenic raw materials of the chemical, metallurgical, petrochemical industries and production of construction materials." May 12-14, Tashkent - 2022, p. 389-391.
10. Khurmamatov, A.M. Umarov, E.S. (2022). Scientific and Technical Journal of FerPI, **26(4)**, 215-219.
11. Umarov, E.S. (2022). Scientific and Technical Journal of FerPI, **26 (5)**, 206-210
12. Umarov E.S. (2022). Scientific and Technical Journal of FerPI, special issue 7, 34-38.
13. Gapparov, K.G., Tohiboev, B.T., Mansurov, Y.N. (2022) Metallurgist **65(11)**, 1331-1337
14. Gapparov, K.G., Erkaboev, H.J., Mansurov, Y.N., Aksenov, A.A. (2021). Metallurgist, **65**, 549-555.
15. Abdulkhaev, Z., et.al., (2023). AIP Conference Proceedings **2789**, 1
16. Samiev, L., et.al., (2023). E3S Web of Conferences **452**, 02022
17. Samiev, L., et.al., (2023). E3S Web of Conferences **452**, 02019
18. Abdulkhaev, Z., Abdujalilova, S., Abumalikov, R. (2023). Journal of Construction and Engineering Technology, **1(1)**, 1-4.
19. Madaliev, M., Qurbanova, N., Rustamova, X. (2023). *Numerical Decisions of the Problem of the Centrifugal Separator Based on the Sarc Turbulence Model*. Journal of Construction and Engineering Technology, 12-17.
20. Ibrokhimov, A., et.al.,(2023). E3S Web of Conferences **452**, 02026
21. Madaliev, E., et.al., (2024). E3S Web of Conferences **508**, 06001