

# Optoelectronic device for measuring the humidity of silkworm cocoons

*Golibzhon Kuldashov<sup>1</sup>, Baxtiyorjon Daliyev<sup>1</sup>, Abdullajon Komilov<sup>1</sup>, Muxiddinjon Tillaboev<sup>1,\*</sup>, and Muhammadmusa Khalilov<sup>1</sup>*

<sup>1</sup>Fergana branch of TUIT named after. Muhammad al-Khwarizmi, Fergana, Uzbekistan

**Abstract.** Purpose given work was creation of an optoelectronic device for measuring the humidity of silkworm cocoons on basis mid-IR LEDs. An optoelectronic device has been developed for measuring the humidity of silkworm cocoons based on mid-IR LEDs, allowing measurements in real mode with an accuracy of 1.5%. Analysis of the spectral characteristics of silkworm cocoons shows that in the optical range of 0.4...1.2  $\mu\text{m}$ , the cocoon shell transmits radiation well, and radiation with a wavelength of 1...2  $\mu\text{m}$  is well reflected. In the spectral region of 1.8-2.2  $\mu\text{m}$ , the reflectivity of silkworm cocoons is 85%, then drops to 14% at wavelengths of 3  $\mu\text{m}$ . Transmission of radiation by the pupa in the spectral region of 0.4-10  $\mu\text{m}$  was not detected. The obtained data on the optical properties of silkworm cocoons made it possible to use the principle of reflection to control humidity, because at wavelengths of 1.95 and 2.22  $\mu\text{m}$ , where there are maxima and minima of water absorption, the shell of silkworm cocoons transmits little IR radiation, but at these wavelengths it has good reflectivity, so it is necessary to use the principle of reflection of IR radiation. In the optoelectronic device for measuring the humidity of silkworm cocoons, LEDs with emission spectra of 2.2  $\mu\text{m}$  are used as a reference channel, and LEDs with emission spectra of 1.94  $\mu\text{m}$  are used as a measuring channel. To record signals, a photodiode with a wide sensitivity range of 1.5 - 2.4  $\mu\text{m}$  was used. A schematic diagram has been proposed that ensures the main condition for two-wave optoelectronic devices, in terms of timing and temperature stability of LED parameters and the equality of their initial reference, measuring radiation fluxes, which determine the measurement accuracy.

## 1 Introduction

One of the important parameters of many technological processes, by which the quality of the finished product is determined, is humidity. Work on the development of new instruments for measuring humidity is being carried out here in Uzbekistan and abroad. A wide range of research in the field of moisture measurement is stimulated by the practical demands of the national economy for express and highly sensitive methods and means of moisture measurement [1-2].

\* Corresponding author: [muxiddinjon.tillaboyev3401@gmail.com](mailto:muxiddinjon.tillaboyev3401@gmail.com)

The most promising direction is optical hygrometry, the basis of which is the property of water to absorb infrared radiation of a certain wavelength. The presence of absorption bands characteristic of water in the mid-IR optical region makes it possible to develop devices for various materials in which it is necessary to measure moisture [3-5].

The operation of optical moisture meters is based on the selective absorption by moisture of infrared radiation of a certain wavelength reflected from the surface of the controlled object or passed through the substance.

## 2 Spectral characteristics of wet materials

During atomic polarization, the oxygen atoms that make up water undergo a complex movement, which is caused by the synthesis of three standard vibrations: absolutely symmetric angular, absolutely symmetric elastic, asymmetric elastic. The absorption bands of these vibrations are respectively 2.74 ; 6.27 and 2.66  $\mu\text{m}$ . The absorption rates at these wavelengths are very high, however, due to the lack of stable LEDs and receivers of mid-IR radiation, these wavelengths are not used in the development of industrial devices. The most optimal wavelength for practical use is 1.94  $\mu\text{m}$ . Since the absorption of water in this range is in the nature of induced polarization accompanying atomic vibrations, this phenomenon is considered atomic polarization. Water entering a substance changes its spectrum. From the different spectral characteristics of dry matter (Fig. 1, curve 1) and at a humidity of 9%  $\text{H}_2\text{O}$  (curve 2) it follows that at a wavelength of 1.94  $\mu\text{m}$  water has significant absorption.

Consequently, if the controlled object is irradiated with IR – radiation with such a wavelength and measure the power of the transmitted or reflected radiation flux, then it will vary depending on humidity.

However, when measuring at only one wavelength, errors arise, the main sources of which, in addition to humidity, are the scattering of radiation by the substance being measured, its thickness, etc. To eliminate these errors, another radiation flux is used with a reference wavelength lying outside the moisture absorption band.

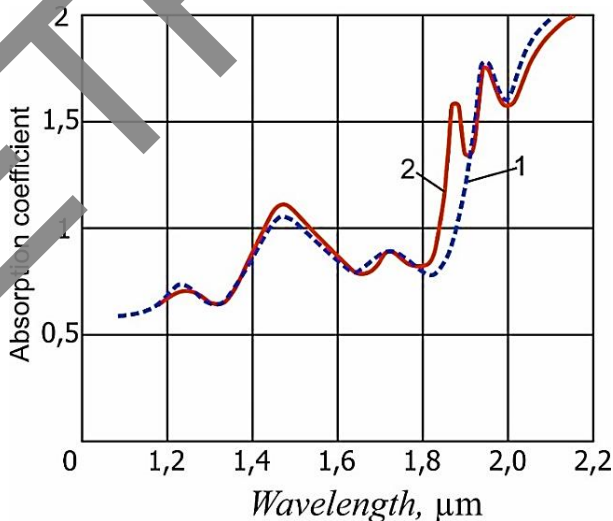

**Fig.1.** Spectral characteristics of dry (1) and wet (2) matter

### 3 Method for selecting the wavelength of analyzing radiation

The wavelengths of the measuring and reference flows can be selected optimally, taking into account the spectrum of the substance being measured, the humidity measurement range and other requirements. When constructing optoelectronic devices using semiconductor emitters, spectral characteristics are the basis on which the wavelengths of the measuring and reference radiation fluxes are selected.

To develop devices based on the use of optical radiation, the spectral characteristics of the cocoon (reflection spectra and transmission spectra of radiation) and the dependences of transmission, reflection and scattering of radiation are necessary.

The cocoon shell ultimately protects the pupa from cold and heat and creates favorable conditions for the living organism. Based on this, the cocoon shell allows radiation necessary for the life of the pupa to pass through and does not allow harmful radiation to pass through. That is, the shell of the cocoon reflects radiation with a wavelength harmful to the pupa, and transmits radiation with a wavelength necessary for the pupa [6]. In our case, knowledge of the reflection and transmission spectra is necessary to select a radiation source with the required wavelength.[16-22]

Analysis of the results of studies of the optical properties of silk worm cocoons showed the feasibility of using IR radiation to control humidity. Of the optical characteristics, the greatest interest for monitoring the humidity of silkworm cocoons, infrared radiation, is transmittance, reflectance and absorptivity, and the ratio of the past. Reflected and absorbed IR radiation is characterized by corresponding coefficients depending on the wavelength and physical properties of silkworm cocoons. The effectiveness of using IR radiation to control humidity depends on the correct combination of the optical properties of the semiconductor emitter and the irradiated material.

In Fig. Figures 2 and 3 show the experimentally obtained spectral characteristics of the cocoon. Analysis of the spectral characteristics shows that in the optical range of 0.4...1.2  $\mu\text{m}$  the cocoon shell transmits radiation well.

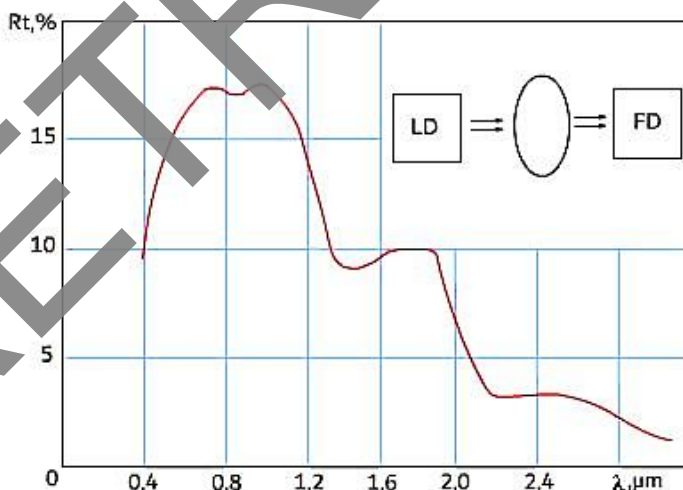

Fig.2. Spectral characteristics of the reflection of infrared radiation of the cocoon

Radiation with a wavelength of 1...2  $\mu\text{m}$  is well reflected by the cocoon shell [7-8]. These circumstances will be taken into account when choosing the wavelength of the emitter for the development of devices for determining process parameters. In the spectral

region of 1.8-2.2 microns, reflectivity is 85%, then drops to 14 % at wavelengths 3  $\mu\text{m}$  . \_ Transmission of radiation by the pupa in the spectral region of 0.4-10  $\mu\text{m}$  was not detected.

Semiconductor optoelectronic devices can be composed according to the type of optical circuit of the sensor, the number of wavelengths of analyzing radiation, the principle of constructing a block diagram, as well as the principle of converting the controlled component into an electrical signal.

Depending on the method of receiving optical radiation after interaction with a substance, the following methods should be distinguished, based on the reception of radiation passed through the object and the reception of radiation reflected from the surface of the object [9-12] .

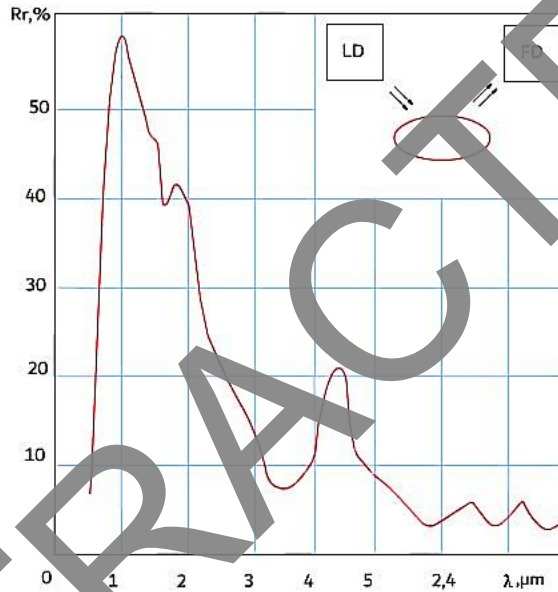

**Fig.3.** Spectral reflections of infrared radiation

The obtained data on the optical properties of the shell of silkworm cocoons made it possible to use the principle of reflection to control humidity, because at wavelengths of 1.95 and 2.22  $\mu\text{m}$  , where there are maxima and minima of water absorption, the shell of silkworm cocoons transmits little IR radiation, but at these wavelengths it has good reflectivity, so it is necessary to use the principle of reflection of IR radiation.

To control the humidity of silkworm cocoons, we use an LED with a maximum at wavelength 2  $\mu\text{m}$  as a reference signal . 2  $\mu\text{m}$  (LED22), and as a measuring signal we use an LED with a maximum at wavelength 1 . 94  $\mu\text{m}$  (LED19). To record signals we use a PD24 photodiode with a wide sensitivity range of 1.5 - 2 . 4  $\mu\text{m}$  . Figure 4 shows the main spectral characteristics of LED19, LED22 and photodiode PD24.

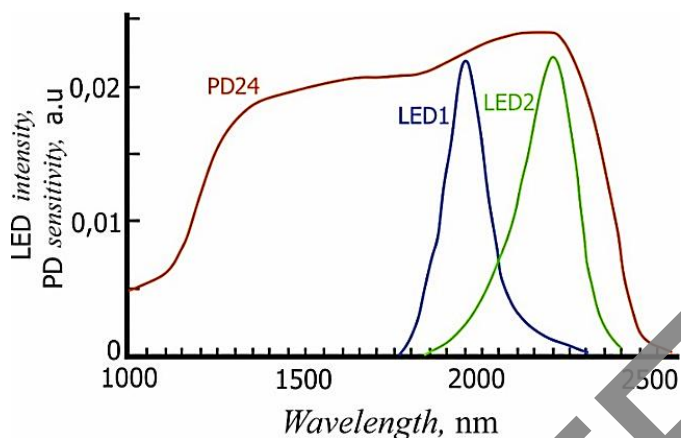

**Fig. 4.** Emission spectra of LEDs LED19, LED22 and spectral sensitivity of photodiode PD24.

#### 4 Optoelectronic device for measuring the humidity of silkworm cocoons

Proposed an optoelectronic method and device, which is designed to measure the humidity of silkworm cocoons, the operating principle of which is as follows: silkworm cocoons are irradiated with two streams  $F_{0\lambda1}$  and  $F_{0\lambda2}$  at the reference ( $\lambda = 2.22 \mu m$ ) and measuring ( $\lambda = 1.94 \mu m$ ) wavelengths, respectively.

The passed flow from the controlled objects described by the expression:

$$\begin{cases} F_{\lambda1} = \gamma_{\lambda1} \cdot F_{0\lambda1} \\ F_{\lambda2} = \gamma_{\lambda2} \cdot F_{0\lambda2} \cdot e^{-km} \end{cases}$$

where:  $\gamma_{\lambda1}, \gamma_{\lambda2}$  – transmittance coefficients of the reference and measuring wavelengths,  $k$  – absorption coefficient,  $m$  – moisture mass.

Let  $F_{\lambda1} = A \cdot e^{-t/\tau}$ , then 
$$\begin{cases} F_{\lambda1} = \gamma_{\lambda1} \cdot F_{0\lambda1} \cdot e^{-t/\tau} \\ F_{\lambda1} = \gamma_{\lambda2} \cdot F_{0\lambda2} \cdot e^{-km} \end{cases}$$

At the moment of comparing the fluxes of the reference and measuring wavelengths, i.e.  $F_{\lambda1} = F_{\lambda2}$  or  $\gamma_{\lambda1} \cdot A \cdot e^{-t/\tau} = \gamma_{\lambda2} \cdot F_{0\lambda2} \cdot e^{-km}$ , usually  $\gamma_{\lambda1} = \gamma_{\lambda2}$ , then  $m = -\frac{1}{K \cdot \tau} \cdot t$ , i.e. the mass of moisture of the cocoons is proportional to the comparison of time intervals.

A block diagram of an optoelectronic device for measuring the humidity of silkworm cocoons is shown in Fig. 5.

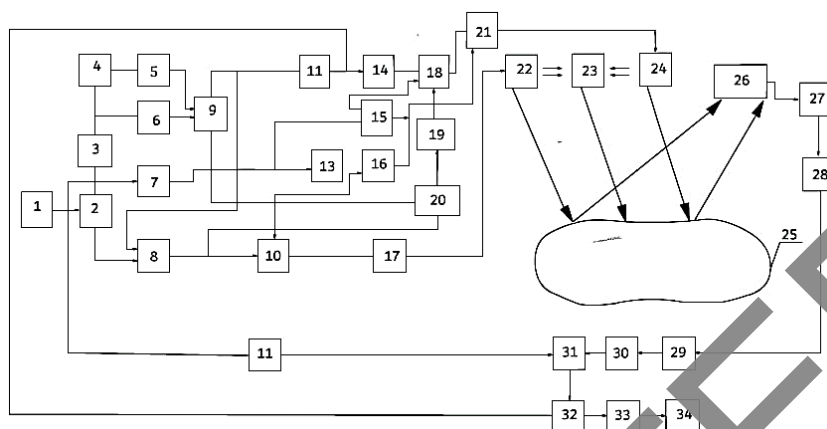

**Fig.5.** Block diagram of an optoelectronic device for measuring the humidity of silkworm cocoons

Optoelectronic device for measuring the humidity of silkworm cocoons ( Fig . 5 ) : master oscillator – 1, trigger – 2, first frequency divider – 3, second frequency divider – 4, second differentiating device – 5, first differentiating device – 6, third frequency divider – 7, first comparison circuit – 8, RS trigger – 9, second analog switch – 10, fifth differentiating device – 11, third differentiating device – 12, second logical element “NOT” – 13, exponential function generator – 14, first analog memory – 15, second analog memory – 16, second emitter follower – 17, first analog switch – 18, first logical element “NOT” – 19, logical element “OR” – 20, first emitter follower – 21, infrared radiation source emitting reference wavelengths – 22, additional photodetector of infrared radiation – 23, source of infrared radiation emitting at analytical wavelengths – 24, cuvette for the analyzed sample – 25, photodetector of infrared radiation – 26, low-noise amplifier – 27, selective amplifier – 28, threshold device – 29, fourth differentiating device – 30, second comparison circuit – 31, counter – 32, decoder – 33, indicator – 34.

In order to improve accuracy optoelectronic device for measuring the humidity of silkworm cocoons, an additional photodetector is introduced into the circuit, providing optical negative feedback to stabilize the parameters (radiation power, radiation intensity, radiation flux, maximum radiation spectrum, forward current, forward voltage) of mid-IR LEDs.[23-29]

A schematic diagram (Fig. 6) has been developed to eliminate time and temperature instability, as well as to ensure equality of the initial measuring and reference radiation fluxes of mid-IR LEDs used in two-wave optoelectronic automatic control devices .

The electrical circuit diagram uses:

- A1-A2-A3 – operational amplifier LMC7101;
- T1, T3 - bipolar transistors BF470 ;
- T2, T5, T6 – field-effect transistors KP305A;
- MC1 - logic chip K561LA7;
- MS3, MS6 - logic chips K561LA7;
- MC2-JK-trigger K561TV1.

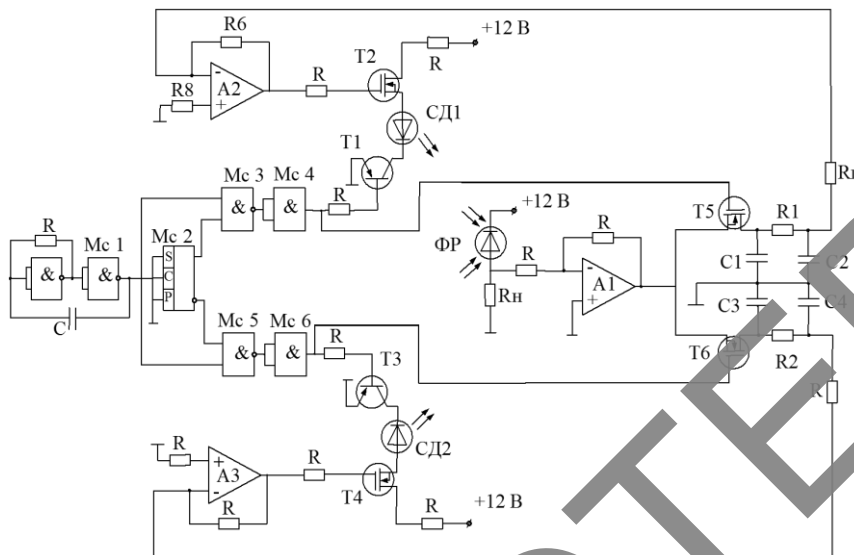

**Fig.6.** Schematic diagram for stabilizing reference and measurement wavelength LEDs.

## 5 Conclusion

An optoelectronic device has been developed to measure the humidity of silkworm cocoons at basis method selective optical absorption using mid-infrared LEDs. A scheme has been proposed that provides the main condition for two-wave optoelectronic devices, in terms of timing and temperature stability of the parameters of the LEDs and the equality of their initial reference, measuring radiation fluxes, which determine the accuracy of the measurement.

Based on the results obtained, it was made to measure the humidity of silkworm cocoons , allowing measurements in the range from 1 to 40% with an error of no more than 1.5%.

## References

1. Zhang J., Du S., Kafi A., Fox B., Li JL, Liu XY, Rajkhowaa R., Wang XG *Surface energy of silk fibroin and mechanical properties of silk cocoon composites*. 2015. RSC Adv. **5**, 1640–1647.
2. Hendawi M (2017) *J. Soil Sci. and Agric. Eng., Mansoura Univ.*, Vol. **8(4)**:149 - 156
3. Nakamura S. Background Story of the Invention of Efficient InGaN Blue-Light-Emitting Diodes (Nobel Lecture) // *Angew. Chemie - Int. Ed.* 2015. doi: 10.1002/anie.201500591
4. Bekkamov Ch.I., Umarov Sh.R. *The influence of feeding rate and temperature on technological parameters of cocoons*. Agrarian science. 2019;**(10)**:43-45.
5. Karunatilaka D., Zafar F., Kalavally V., and R. Parthiban, “LED based indoor visible light communications: State of the art,” *IEEE Commun. Surv. Tutorials*. 2015. doi: 10.1109/COMST.2015.2417576. b.1649 – 1678.
6. Wang Y., Alonso J.M. and X. Ruan, “A Review of LED Drivers and Related Technologies,” *IEEE Transactions on Industrial Electronics*. 2017. doi: 10.1109/TIE.2017.2677335.

7. Xudoyberdiyev T.S., Boltaboev B.R., Razzakov B.A., Kholdarov M.Sh. //Asian Journal of Multidimensional Research (AJMR) // **Vol. 9**, Issue 8, August, 2020.
8. Erkinov D.D., Safarov Zh.E. *Study of the characteristics of silkworm cocoons*. Collection of reports of the Republican Scientific and Technical Conference “The Role of Intellectual Youth in the Development of Science and Technology”. Tashkent, 2018. P.100-101.
9. Kuldashov O.Kh., Kuldashov G.O., Mamasodikova Z.Y. // J. Opt. Technol. – 2019. **No. 6**. – P. 77 – 80. doi: 10.1364/jot.86.000390.
10. Abdurakhmonov S.M., Kuldashov O.Kh., Tozhiboev IT, Turgunov B.K. *The Optoelectronic Two-Wave Method for Remote Monitoring of the Content of Methane in the Atmosphere* // Tech. Phys. Lett. – 2019. doi: 10.1134/S1063785019020214.
11. Ergashev S.F., Kuldashov O.Kh., Mamasodikova U.Yu. // Applied Solar Energy. 2007. **Vol 43**. P.68–71.
12. Kuldashov O.Kh., Umaraliev. N., Ergashev, KM // Scientific-technical journal: 2021. **Vol. 4**: Iss.2/ Article 5. Available at: [https://uzjournals.edu.uz/ferpi/vol4\\_iss2/5](https://uzjournals.edu.uz/ferpi/vol4_iss2/5)
13. Rayimdjanova, O., Iskandarov, U., Ergashev, S., Tillaboev, M. // E3S Web of Conferences, 2023, **452**, 01011
14. Ismoilov, M. M., Obidova, G., Juraeva, M., Meliqo'ziev, A., Maxkamova, D., Toshpo'latova, M. (2024) E3S Web of Conferences **508**, 06002. <https://doi.org/10.1051/e3sconf/202450806002>
15. Rayimdjanova, O., Mukhtarov, F., Ismoilov, M. M., Abdusamatov, H., Abdullaeva, M., Madaminov, M. (2024) E3S Web of Conferences **508**, 01004. <https://doi.org/10.1051/e3sconf/202450801004>
16. Madaliev, M., Usmonov, M., Kadyrov, K., Abdullajonov, N., Mavlonova, D., Otakhanova, Z., Muminov, K. (2024) E3S Web of Conferences **508**, 06005
17. Madaliev, M., Usmonov, M., Orzayonov, J., Bilolov, I., Otakhanova, Z., Rajabova, K., Israilov, S. (2024) E3S Web of Conferences **508**, 06003
18. Madaliev, M., Abdulkhadirov, Z., Kurpayanidi, K., Abdullayev, A., Ilyosov, A. (2024) E3S Web of Conferences **508**, 06007
19. Abduraimov, B., Orzimatov, J., Usmonov, M., Mullayev, I., Raxmonkulova, S., Qosimov, A., Sirojiddinov, D. (2024). E3S Web of Conferences **508**, 02002
20. Salomov, U., Madaliyev, M., Kuchkarov, A. (2024). BIO Web of Conferences **84**, 02024
21. Salomov, U. R., Chiavazzo, E., Asinari, P. (2014). Computers & Mathematics with Applications, **67(2)**, 393-411.
22. Salomov, U. R., Chiavazzo, E., Fasano, M., Asinari, P. (2017) International Journal of Hydrogen Energy, **42(43)**, 26730-26743.
23. Salomov, U., Abduraxmonov, S., Urishev, O., Juraev, N. (2024). BIO Web of Conferences **84**, 05028
24. Lesnikova, E. P., Jakhongirov, I. J. O., Sadykova, K. V., Zakharova, T. I., Santalova, M. S. (2021). *Management of innovative working behavior*. In Modern Global Economic System: Evolutional Development vs. Revolutionary Leap 11 (pp. 1008-1016). Springer International Publishing.
25. Obrenovic, B., Gu, X., Wang, G., Godinic, D., Jakhongirov, I. (2024). *Generative AI and human–robot interaction: implications and future agenda for business, society and ethics*. AI & SOCIETY, 1-14.

26. Usarov, M., Ayubov, G., Usarov, D., Mamatisaev, G. (2022). *Spatial Vibrations of High-Rise Buildings Using a Plate Model*. In Proceedings of MPCPE 2021: Selected Papers (pp. 403-418). Cham: Springer International Publishing.
27. Usarov, M., Mamatisaev, G., Ayubov, G., Usarov, D., Khodzhaev, D. (2020) IOP Conference Series: Materials Science and Engineering **883**, 1, 012186
28. Usarov, M., Mamatisaev, G., Usarov, D. (2023). AIP Conference Proceedings **2612**, 1
29. Usarov, M., Usarov, D., Mamatisaev, G. (2022). Calculation of a Spatial Model of a Box-Type Structure in the LIRA Design System Using the Finite Difference Method Lecture Notes in Networks and Systems.
30. Rayimdjanoval, O., Xatamova, Z., Rustamov, I., Xolmatov, S., Arabboyev, M., & Ibragimov, N. Z. Thermal converter for controlling horizontal wind speed and temperature. In *E3S Web of Conferences* (Vol. 508, p. 05004). EDP Sciences. <https://doi.org/10.1051/e3sconf/202450805004>
31. Kuldashov, O., Rayimdjanoval, O., Djalilov, B., Ergashev, S., Tojiroval, S., & Muhammadjonov, A. (2024, November). Stabilization of parameters of optoelectronic devices on semiconductor emitters. In *E3S Web of Conferences* (Vol. 508, p. 01001). EDP Sciences. <https://doi.org/10.1051/e3sconf/202450801001>
32. Nurdinova, R., Rayimjonova, O., Djalilov, B., & Iskandarov, U. (2024, March). Determination of the near areas of micro parameters for anomalous photo voltage elements. In *AIP Conference Proceedings* (Vol. 3045, No. 1). AIP Publishing.
33. Nurdinova, R., Rayimjonova, O., Djalilov, B., & Iskandarov, U. (2024, March). Determination of the near areas of micro parameters for anomalous photo voltage elements. In *AIP Conference Proceedings* (Vol. 3045, No. 1). AIP Publishing.
34. Rayimdjanoval, O., Iskandarov, U., Juraeva, G., & Ergashev, S. (2024, March). Research of the highly sensitive deformation sensor. In *AIP Conference Proceedings* (Vol. 3045, No. 1). AIP Publishing.
35. Mukhtarov, F., Jo'rayeva, N., Zokirov, S., Sadikova, M., Muhammadjonov, A., & Iskandarova, N. (2024, November). Analysis of automation through sensors through gas sensors in different directions. In *E3S Web of Conferences* (Vol. 508, p. 06004).
36. Kasimakhunova, A. M., & Zokirov, S. I. (2024). Development of a simulation model for an automated hybrid photothermogenerator. In *Artificial Intelligence, Blockchain, Computing and Security Volume 2* (pp. 616-621). CRC Press.
37. Akhundjanov, U., Soliyev, B., Kayumov, A., Kholmatov, A., Musayev, K., & Ermatova, Z. (2024). Distribution of local curvature values as a sign for static signature verification. In *E3S Web of Conferences* (Vol. 508, p. 03003). EDP Sciences.
38. Akhundjanov, U., Soliyev, B., Juraev, N., Musayev, K., Norinov, M., Ermatova, Z., & Zaynabidinov, R. (2024, November). Off-line handwritten signature verification based on machine learning. In *E3S Web of Conferences* (Vol. 508, p. 03011). EDP Sciences.
39. Zulunov, R., Akhundjanov, U., Musayev, K., Soliyev, B., Kayumov, A., & Asraev, M. (2024, November). Building and predicting a neural network in python. In *E3S Web of Conferences* (Vol. 508, p. 04005). EDP Sciences.