

Wind-PV-Battery Powered Standalone Microgrid with TS-Fuzzy Controllers based Novel Control for Power Quality Improvement

Devadula Eswara Saraswathi and Gopalamma S L K Aravelli

Devadula Eswara Saraswathi, M.Tech Power and Industrial Drives, Dadi Institute of Engineering and Technology, Anakapalli, Visakhapatnam, Andhra Pradesh, India.

Gopalamma S L K Aravelli, Associate professor, Dept. of Electrical and Electronics Engineering, Dadi Institute of Engineering and Technology, Anakapalli, Visakhapatnam, Andhra Pradesh, India.

Abstract: The global community is actively investigating strategies to harness renewable energy power sources (REPS) in order to tackle the problem of global warming and reduce reliance on fossil fuels. Wind and solar energies are among the most plentiful and easily accessible forms of renewable energy available on Earth. Utilizing these sources for electrical power generation can prove to be an effective solution in meeting the energy demands of various regions. Photovoltaics (PVs) and Permanent Magnet Synchronous Generator (PMSG) coupled wind power conversion units are commonly installed for medium power applications. By integrating these two sources, a reliable and flexible power supply can be ensured for consumers at all times. Additionally, the incorporation of an energy storage device, such as batteries, is essential for maintaining energy management in standalone power supply units. As a result, a hybrid wind, battery and PV based microgrid has been developed, along with a novel control technique to ensure power quality at the load point. Traditional controllers like the Proportional-Integral (PI) controller may not perform optimally during rapid system changes due to their fixed gains. Therefore, a novel TS-Fuzzy controller-based control scheme has been implemented in this system. To optimize the utilization of REPS, the system has been equipped with devices that ensure maximum power point integration. The energy management system is facilitated by connecting the battery bank to the system through a DC to DC bidirectional circuit. The results of various case studies have been presented using the MATLAB software in this study.

Keywords: PV, Wind power conversion, batteries, Power Quality, Standalone Microgrid.

Corresponding Author: gopika.aravelli@gmail.com

1. Introduction

Electricity plays a crucial role in meeting our daily needs. However, there are still numerous places around the world that lack access to electricity. One effective solution for providing electricity in these remote areas is the implementation of locally placed standalone microgrids [1]. Furthermore, the world is currently facing the detrimental effects of toxic gases emitted by fossil fuels, which are often burned for electric power generation. To combat this issue, utilizing REPS for electricity generation proves to be the most viable solution. By harnessing renewable energy, we can not only reduce global warming but also cater to the energy demands of remote locations.

It is important to note that relying solely on a single REPS may not guarantee a consistent power supply for consumers. Therefore, integrating various power generating units can enhance the reliability of the system, ensuring a stable and high-quality power supply to remote areas. Photovoltaics (PVs) and PMSG coupled wind power generation units are two notable power conversion methods that are well-suited for providing electricity to customers in isolated areas. Additionally, the inclusion of an energy storage device becomes imperative in maintaining a balance between load and power production, particularly in standalone systems where both variables fluctuate independently.

The battery bank, when appropriately rated, serves as an energy storage device in standalone systems based on REPS. It is comprised of multiple batteries connected in series and parallel configurations, depending on the required power and voltage values. Typically, batteries can respond promptly to sudden changes in the standalone system. During periods of surplus generation in relation to the load, it becomes necessary to charge the battery unit. Conversely, when there is low generation, the battery bank should be discharged. Hence, it is imperative to have a bidirectional DC to DC circuit equipped with an efficient control method in order to effectively handle the discharging and charging operations of the battery bank, taking into account any power imbalances that may arise between the load and the overall generation. To enhance the utilization of different REPS, individual maximum power point tracking (MPPT) circuits are employed for optimal performance. In order to reduce the amount of converters and establish an economical system, the bidirectional circuit, along with the battery, is utilized as the MPPT circuit for the PV unit by merging the MPPT method of the PV unit with the control of the bidirectional DC to DC circuit. Furthermore, this study introduces a novel approach to inverter control, aiming to ensure a consistent voltage at the load bus even in situations of unbalanced voltage. This strategy ultimately improves power quality. Furthermore, the proposed inverter control can also compensate for reactive power requirements of the load, reducing oscillations in the DC-link voltage. Given the inherent imbalance caused by single-phase loads operated at the AC bus, the inverter control must adapt variable modulation indexes to ensure a balanced voltage at the AC bus, even when unbalanced currents flow through these loads. To maintain power quality in standalone systems, it is crucial to establish an effective energy management process.

PI controllers, which are considered conventional controllers, are unable to demonstrate their optimal performance when faced with rapid changes in the system. This is because the gains of these controllers are fixed and tuned at a specific moment [6-7]. Consequently, it is necessary to incorporate automatic adjustable gains that can adapt to changes in the system within the proposed control schemes. To address this requirement, Takagi-Sugeno Fuzzy (TS-Fuzzy) controllers are employed in the proposed control methods. These controllers enable the standalone system to achieve a swift and precise response when confronted with sudden changes.

2. Standalone Microgrid Configuration and Control

Version 1: Figure 1 illustrates the hybrid standalone Microgrid, which includes a PV system, a PMSG-based wind turbine, batteries, AC loads and a three-phase inverter.

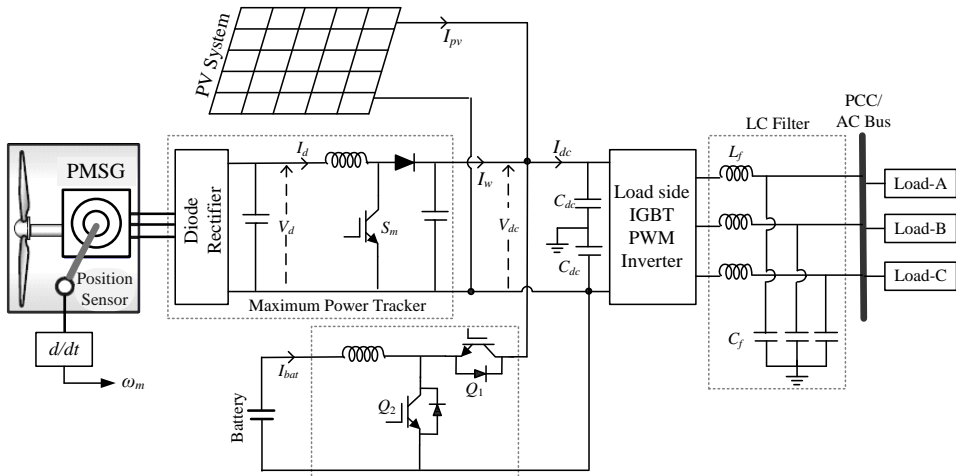

Figure 1: Standalone microgrid.

The standalone hybrid microgrid has been analyzed previously by several authors [8-14]. The authors introduced an energy management plan to control the various units in the microgrid [8]. The comparison of various controllers was conducted by the authors in [9]. In [10], a greenhouse was established by the authors using REPS, although the system was designed for single-phase applications only. The integration of hardware-in-the-loop for a standalone PV system was discussed by the authors in [11]. In [12], the authors presented the operation of a microgrid for hydrogen production using REPS. Furthermore, the authors in [13] have devised an energy management methodology. The authors conducted a comprehensive assessment of different energy management systems for standalone wind, hydrogen and PV based models in [14]. The references from [8-14] did not address the compensation of reactive power and an unbalanced load, and they also did not utilize TS-Fuzzy controllers in the standalone system. This paper focuses on the development of a microgrid based on REPS with the following objectives:

- Enhancing the coordination of control systems for wind, PV, battery, and loads is essential for optimal performance.
- To deploy a TS-Fuzzy controller in order to achieve rapid and accurate responses across different scenarios.
- In order to ensure stable voltages at the load bus while unbalanced currents flow through a 3-phase system.
- Create a streamlined and uncomplicated system for managing energy effectively.

3. Designing of TS-Fuzzy Controller

The TS-Fuzzy controllers utilized in this study were developed based on their fundamental mathematical functions [7]. The input signals for these TS-Fuzzy controllers are derived from the error and its derivative of voltage/current (x_i) and (\dot{x}_i), as depicted in Figure 2. The error and its derivatives serve as inputs for the TS-Fuzzy controllers employed in the respective control scheme. These inputs are further fuzzified using two linguistic membership (MF) values: negative (N) and positive (P). The MFs for the two input linguistic variables, x_i and \dot{x}_i signals, are expressed by the following functions:

$$\eta_P(e_i) = \begin{cases} 0, & e_i < L_1 \\ \frac{e_i + L_1}{2L_1}, & -L_1 \leq e_i \leq L_1 \\ 1, & e_i > L_1 \end{cases} \quad \eta_N(e_i) = \begin{cases} 1, & e_i < L_1 \\ \frac{-e_i + L_1}{2L_1}, & -L_1 \leq e_i \leq L_1 \\ 0, & e_i > L_1 \end{cases} \quad (1)$$

$$\eta_P(\dot{e}_i) = \begin{cases} 0, & \dot{e}_i < L_2 \\ \frac{\dot{e}_i + L_2}{2L_2}, & -L_2 \leq \dot{e}_i \leq L_2 \\ 1, & \dot{e}_i > L_2 \end{cases} \quad \eta_N(\dot{e}_i) = \begin{cases} 1, & \dot{e}_i < L_2 \\ \frac{-\dot{e}_i + L_2}{2L_2}, & -L_2 \leq \dot{e}_i \leq L_2 \\ 0, & \dot{e}_i > L_2 \end{cases} \quad (2)$$

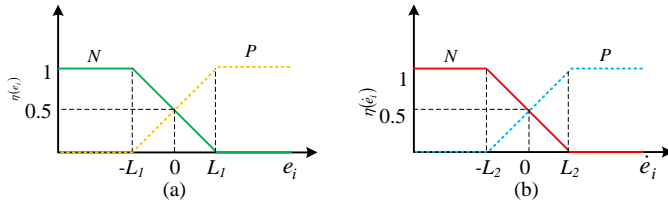

Figure 2: TS-Fuzzy MSFs.

Table-1 presents a compilation of guidelines for TS-Fuzzy controllers. The parameters employed in TS-Fuzzy necessitate tuning and selection, which should be determined by the specific application of TS-Fuzzy.

Table-1: Various rules of TS-fuzzy controllers:

Rules	$e_i(k)$	$\dot{e}_i(k)$	Formulas
A	N	N	$Z_1 = c_1 e_i(k) + c_2 \dot{e}_i(k)$
B	N	P	$Z_2 = c_3 Z_1$
C	P	N	$Z_3 = c_4 Z_1$
D	P	P	$Z_4 = c_5 Z_1$

In the above rules, Z_{1-4} indicates the consequent of the TS-Fuzzy controllers, k is the k^{th} instant. c_1, c_2, c_3, c_4 and c_5 are the constants. The adjustment process tunes the fuzzy constants' values, which differ across TS-Fuzzy controllers.

The TS-Fuzzy controller produces the output (Y) through the utilization of the generalized defuzzifier, as determined by equation (3).

$$Y = \frac{Z_1 B_1 + Z_2 B_2 + Z_3 B_3 + Z_4 B_4}{Z_1 + Z_2 + Z_3 + Z_4} \quad (3)$$

The stability of the power system is enhanced by dynamically adapting the value of "Y" through the implementation of a fuzzy-based controller, thereby improving the system's response to various system events.

4. Proposed Control Schemes and Energy Management System

The DC-link of the battery bank is integrated with a DC to DC bidirectional circuit. The primary objective of incorporating this converter is to regulate the voltage at the DC-link. Figure 3 illustrates the control scheme for the bidirectional circuit, which utilizes TS-Fuzzy controllers. The MPPT algorithm, specifically Perturb and Observe (P&O), is employed to generate the reference dc-link voltage, thereby enabling the converter to function as a

MPPT for the PV modules. Consequently, there is no need for an additional converter to extract maximum energy from PVs. The TS-Fuzzy controller-1 is capable of generating the desired battery current reference through an analysis of the dc-link voltage deficit. The reference battery current is then compared to its actual current to control the discharge and charge of the battery through the DC to DC circuit. In order to avoid both overcharging and discharging of the battery bank, the State of Charge (SoC) can be integrated into the system based on the specific needs. The TS-Fuzzy controller-2 is responsible for generating the required duty cycle of the converter to produce pulses for Q1 and Q2. The comparison between the reference and actual current of the battery bank allows for the accomplishment of this task.

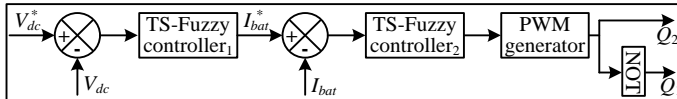

Figure 3: control of bidirectional circuit integrated with the battery system.

In a distribution power supply system, it is customary for single phase loads to be linked to the AC load bus [15-18]. As a result, the current flowing through each phase differs, leading to unbalanced voltages at the AC bus due to uneven drops across the LC filter. To address this issue, it is necessary to implement proper control of the inverter in order to generate counter modulation indexes and compensate for the unbalanced voltages. Furthermore, reactive power compensation is essential for the operation of reactive power loads linked to the AC bus. The RMS voltage at the AC bus is regulated to align with its reference value in order to achieve this. When producing pulses for the inverter, the oscillating component of the direct and quadrature voltage is also taken into account to reduce secondary frequency oscillations originating from the DC link. By eliminating these oscillations, the fatigue life of the PMSG shaft can be improved. The control scheme of the proposed inverter is illustrated in Figure 4, while the corresponding energy management system is depicted in Figure 5.

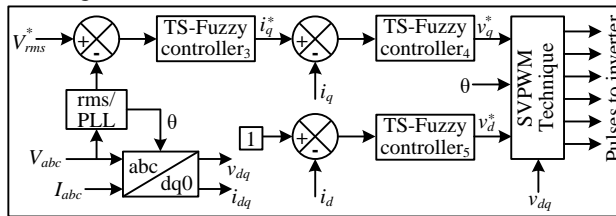

Figure 4: Inverter control based on dq0 method with TS-Fuzzy controllers.

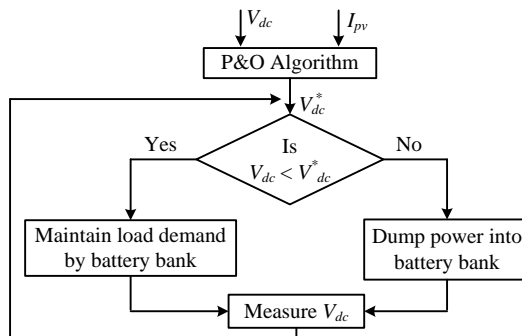

Figure 5: Energy management algorithm.

5. Results

In order to achieve the best possible visualization, the MATLAB/Simulink platform displays outcomes by utilizing a solitary wind and PV system. The significance of the control technique is assessed by analyzing different scenarios of a microgrid, as depicted in Figure 1. Various parameters of the Figure 1 are considered from [19-20].

Case-1: response under various loads

Different types of constant current, impedance and power loads are detailed in reference [19]. Initially, it was assumed that the constant power load, along with a resistive load, is linked at the point of common coupling. The specifications of the constant power load (5 hp induction motor (IM)) are provided as follows:

Resistances: Stator = 1.114Ω , Rotor = 1.081Ω .

Inductances: stator = rotor = $0.005973H$.

The IM is subjected to a load torque of $40Nm$, as shown in figures 6 and 7, which depict the corresponding powers and voltage at dc-link. Figure 8 and Figure 9 illustrate the powers and voltage, respectively, obtained from conducting another test with a constant impedance load.

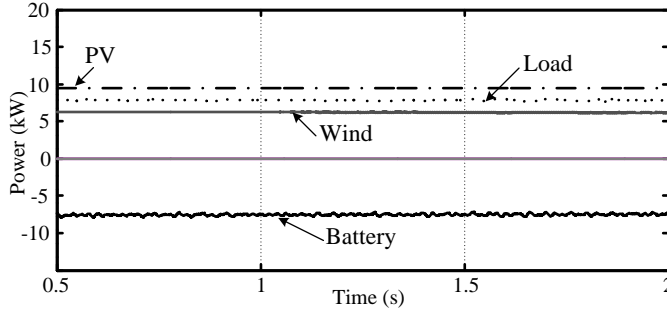

Figure 6: Various powers {Case-1}.

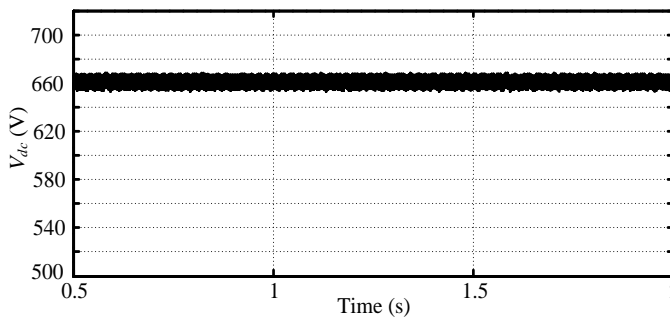

Figure 7: V_{dc} during constant power load {Case-1}.

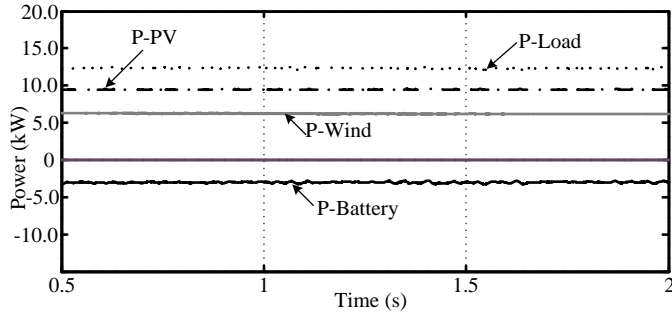
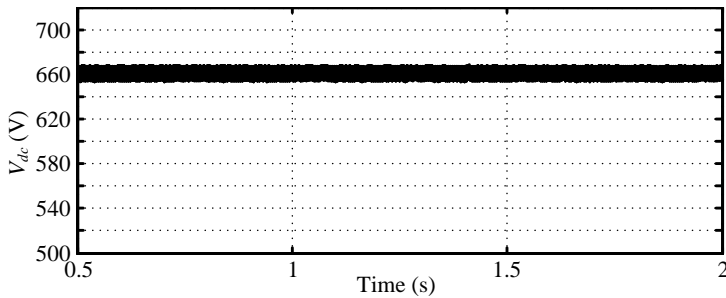

Figure 8: Various Powers {Case-1}.

Figure 9: V_{dc} at DC-link {Case-1}.

The microgrid is undergoing a continuous current load assessment, particularly with variable speed DC drives linked at the PCC via a circuit. In this specific case study, we examine a consistent load torque of 15Nm. However, the speed ranges from 100 to 200 rps, as demonstrated in Figure 10(a). To maintain the speed of the motor, the armature's voltage is controlled by adjusting the duty cycle of the converter, as illustrated in Figure 10(b). The various power levels related to this scenario are depicted in Figure 11, while the corresponding voltage is shown in Figure 12.

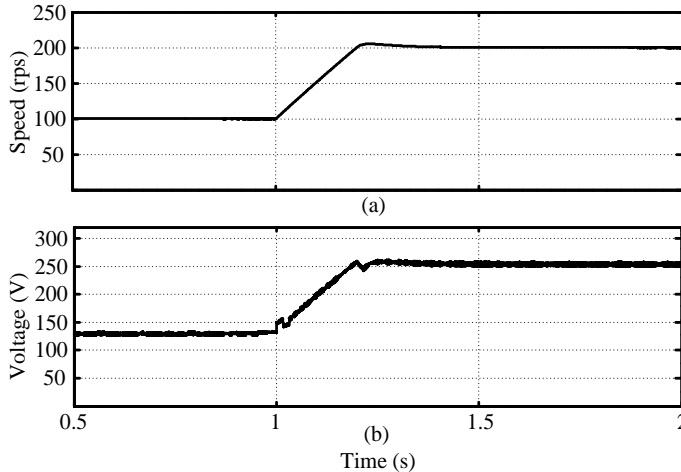

Figure 10: (a) speed, (b) voltage {Case-1}.

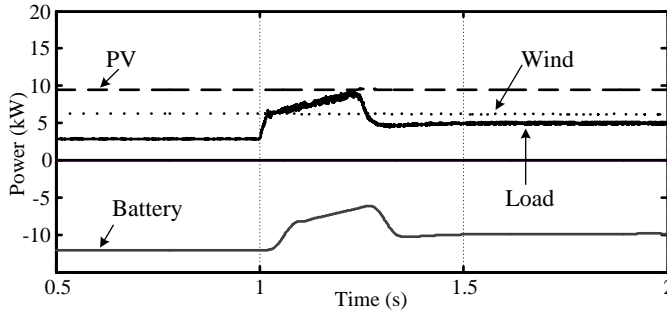

Figure 11: Various powers {Case-1}.

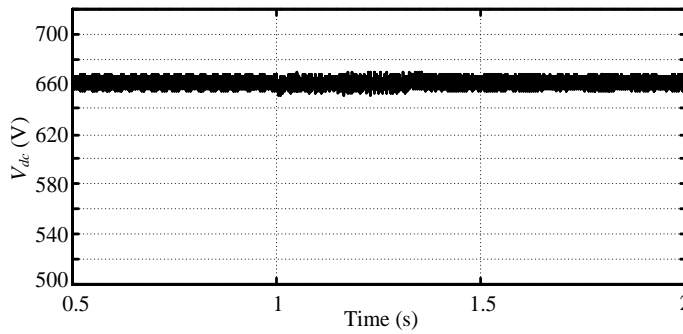

Figure 12: V_{dc} at DC-link {Case-1}.

Case-2: Compensation of Reactive power

The experimental evaluation of the inverter control, as presented in this research paper, focuses on the reactive power needed by the AC load. It should be noted that the reactive power demand from the load gradually rises from 7.5 to 15kVAR at $t=0.8$ sec, as illustrated in Figure 13. The proposed method effectively compensates for this increase in reactive power.

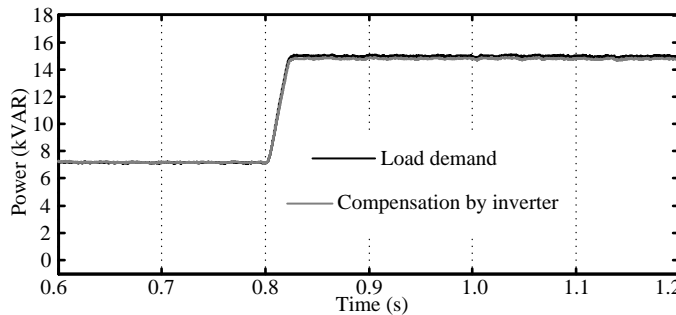

Figure 13: Reactive powers {Case-2}.

Case-3: Comparison of TS-Fuzzy and PI controller

The RMS voltage error signal response at the AC bus, which serves as the input signal for the TS-Fuzzy/PI controller, is shown when the load varies by 200% at $t=2.0$ sec and is suddenly disconnected completely at 2.25 sec. Figure 14 illustrates the response of both the PI and TS-Fuzzy controllers. It is evident from the response that the TS-Fuzzy controller outperforms the PI controller.

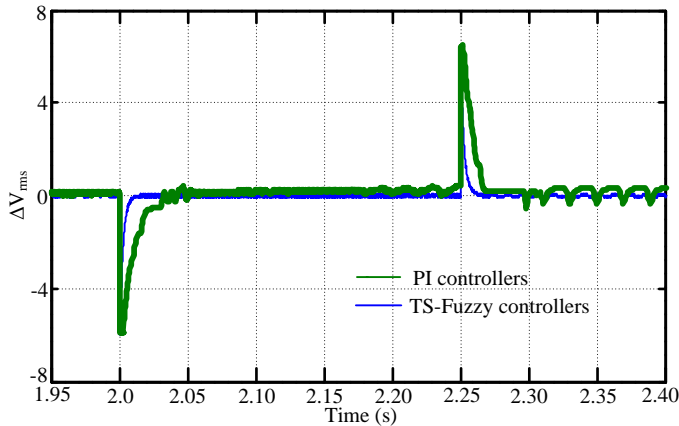

Figure 14: Change in RMS voltage {Case-3}.

6. Conclusion

An effective energy management model is introduced for microgrids based on REPS to enhance power quality through a coordinated control scheme. TS-Fuzzy controllers are utilized to implement the proposed control schemes. The control strategy for the inverter is specifically developed to ensure balanced voltages under unbalanced load conditions in load and to provide reactive power support as needed by the load. This paper showcases the performance of the microgrid under different scenarios, including realistic load models such as constant power, current and impedance. The outcomes are analyzed using Simulink in diverse scenarios.

References:

- [1]. C. N. Bhende, S. Mishra and S. G. Malla, "Permanent Magnet Synchronous Generator-Based Standalone Wind Energy Supply System," *IEEE Transactions on Sustainable Energy*, vol. 2, no. 4, pp. 361-373, Oct. 2011, doi: 10.1109/TSTE.2011.2159253.
- [2]. H. U. R. Habib et al., "Optimal Planning and EMS Design of PV Based Standalone Rural Microgrids," in *IEEE Access*, vol. 9, pp. 32908-32930, 2021, doi: 10.1109/ACCESS.2021.3060031.
- [3]. M. H. Saeed, W. Fangzong, B. A. Kalwar and S. Iqbal, "A Review on Microgrids' Challenges & Perspectives," in *IEEE Access*, vol. 9, pp. 166502-166517, 2021, doi: 10.1109/ACCESS.2021.3135083.
- [4]. Priyanka Malla, "Novel Control Technique for MPPT of PV Standalone System with TSK Fuzzy controller", *International Journal of New Technologies in Science and Engineering (IJNTSE)*, Vol. 8, Issue. 8, pp. 1-7, Aug. 2022.
- [5]. W. Jiang and B. Fahimi, "Active Current Sharing and Source Management in Fuel Cell–Battery Hybrid Power System", *IEEE Transactions on Industrial Electronics*, Vol. 57, No. 2, pp. 752-761, Feb. 2010.
- [6]. B. M. Nguyen, T. Tran, T. Nguyen and G. Nguyen, "Hybridization of Galactic Swarm and Evolution Whale Optimization for Global Search Problem," in *IEEE Access*, vol. 8, pp. 74991-75010, 2020, doi: 10.1109/ACCESS.2020.2988717.
- [7]. S. G. Malla et al., "Whale Optimization Algorithm for PV Based Water Pumping System Driven by BLDC Motor Using Sliding Mode Controller," in *IEEE Journal of Emerging and Selected Topics in Power Electronics*, vol. 10, no. 4, pp. 4832-4844, Aug. 2022, doi: 10.1109/JESTPE.2022.3150008.

- [8]. C. Wang and M. H. Nehrir, "Power Management of a Stand-Alone Wind/Photovoltaic/Fuel Cell Energy System", *IEEE Transactions on Energy Conversion*, Vol. 23, No. 3, pp. 957-967, Sep. 2008.
- [9]. V. V. A. Vasanth and V. Sheeja, "Comparative Analysis of SRF, PI and AWPI Controllers for Hybrid Standalone Microgrid," 2020 International Conference on Power Electronics and Renewable Energy Applications (PEREA), 2020, pp. 1-6, doi: 10.1109/PEREA51218.2020.9339774.
- [10]. H. Caliskan, I. Dincer and A. Hepbasli, "Energy, Exergy and Sustainability Analyses of Hybrid Renewable Energy Based Hydrogen and Electricity Production and Storage Systems: Modeling and Case Study", *Applied Thermal Engineering*, In press (available online 21 April 2012).
- [11]. A. Srinivasan, J. Moirangthem, S. K. Panda and K. R. Krishnanand, "Hardware-in-loop Control of a Standalone Microgrid," 2019 IEEE International Conference on Sustainable Energy Technologies and Systems (ICSETS), 2019, pp. 365-370, doi: 10.1109/ICSETS.2019.8744928.
- [12]. D. Ipsakis, S. Voutetakis, P. Seferlis, F. Stergiopoulos and C. Elmasides, "Power Management Strategies for a Stand-Alone Power System using Renewable Energy Sources and Hydrogen Storage", *International Journal of Hydrogen Energy*, Vol. 34, No. 16, pp. 7081-7095, Aug. 2009.
- [13]. O. Erdinc and M. Uzunoglu, "The Importance of Detailed Data Utilization on the Performance Evaluation of a Grid-Independent Hybrid Renewable Energy System", *International Journal of Hydrogen Energy*, Vol. 36, No. 20, pp. 12664-12677, Oct. 2011.
- [14]. E. Dursun and O. Kilic, "Comparative Evaluation of Different Power Management Strategies of a Stand-Alone PV/Wind/PEMFC Hybrid Power System", *International Journal of Electrical Power and Energy Systems*, Vol. 34, No. 1, pp. 81-89, Jan. 2012.
- [15]. P. Enjeti and S. Kim, "A new DC-side active filter for inverter power supplies compensates for unbalanced and nonlinear loads," *Proceedings of IEEE Industry Applications Society Annual Meeting*, Vol. 1, pp. 1023-1031, 1991.
- [16]. Z. W. Geem, "Size Optimization for a Hybrid Photovoltaic-Wind Energy System", *International Journal of Electrical Power and Energy Systems*, Vol. 42, No. 1, pp. 448-451, Nov. 2012.
- [17]. Phommixay, Sengthavy, et al. "Review on the cost optimization of microgrids via particle swarm optimization", *International Journal of Energy and Environmental Engineering*, vol. 11, no. 1, Mar. 2020.
- [18]. R. Robichaud, G. Mosey and D. Olis, "Renewable Energy Optimization Report for Naval Station Newport", *Technical Report NREL*, Feb. 2012.
- [19]. B. K. Mathur, "The Modeling of Load Characteristics Representation in System Studies", *IEEE Transactions on Industry Applications*, Vol. IA-20, No. 1, pp. 167-172, Jan. 1984.
- [20]. Kandi Bhanu Prakash, "PV-Battery based standalone power supply system for rural applications", *International Journal of New Technologies in Science and Engineering (IJNTSE)*, Vol. 8, Issue. 12, pp. 9-13, Dec. 2022.