

Power Quality Improvement of PV-Battery based Hybrid Standalone AC Microgrid

Mala Mathur, Kavitha R, Pankaj Saraswat and Kuldeep Singh Kulhar

Mala Mathur, Professor, Civil Engineering, Vivekananda Global University, Jaipur, India, Email Id-mathur.mala@vgu.ac.in

Kavitha R, Professor, Department of Computer Science and Information Technology, Jain (Deemed to be University), Bangalore, India, Email Id- kavitha.r@jainuniversity.ac.in

Mr. Pankaj Saraswat, Scholar, Department of Computer Science and Engineering, Sanskriti University, Mathura, Uttar Pradesh, India, Email Id-pankajsaraswat.cse@sanskriti.edu.in

Kuldeep Singh Kulhar, Professor, Civil Engineering, Vivekananda Global University, Jaipur, India, Email Id-k.singh@vgu.ac.in

Abstract— Electricity generation through Photovoltaic (PV) for power supply in rural areas is one of the best solution to solve many problems. The standalone power supply by using PV system is attracting by many scholars. However, storage systems like batteries are mandatory to maintain energy management as well as power quality in PV based standalone systems due to random variations in both solar irradiance as well as load. However, the operation of AC loads requires an inverter. Similarly, a bidirectional DC to DC converter is necessary to handle the discharging and charging process of the battery based on the power difference between generation and load. Even during nighttime when there is no power available from PV panels, the battery must supply the power demanded by the loads. To ensure high-quality power supply at the load bus, a novel control system for the inverter has been implemented. Additionally, this paper proposes a novel energy management system to maintain power balance between generation and load. A maximum power point tracker (MPPT) converter has also been integrated into the PV system using the perturbed and observe (P&O) algorithm. Extensive results, obtained through the MATLAB/Simulink package, are presented to demonstrate the significance of the proposed controllers under various operating conditions. The performance of the proposed control schemes remains satisfactory even when the standalone system undergoes various changes.

Keywords— Standalone power supply system, Photovoltaic, renewable energy source, energy management systems.

Corresponding Author: mathur.mala@vgu.ac.in

1. INTRODUCTION

Many number of remote and island locations are there in majority countries worldwide. In such locations, establishment of power grid is too expensive or impractical [1-3]. There is an alternative way to supply electricity in such locations through a diesel generator, but these engines release harmful gases into atmosphere as well as not an economical for long run. Therefore, establishment of a standalone power supply system through Photovoltaic (PV) panels is a best solution for many problems [4-5]. Supplying reliable, quality and stable power at load bus are the main challenges in such standalone systems.

A maximum power point tracking (MPPT) circuit is required to harvest maximum energy from PV panels [5] for increasing efficiency of the overall system. Electrical power produced by PV panels is depending on solar irradiance which varies randomly. As a result, an energy storage system should be required to maintain energy balance between the source (PV) and the load (PCC). Batteries are one of the best energy source devices due to their fast response characteristic during random changes. Hence, a battery bank is considered in this paper to manage power balance between PV and load at PCC. Batteries connected in battery bank should be charged during availability of surplus power and discharge during high load demand than source. To enable an effective method for draining and charging the battery bank, a bi-directional DC to DC converter is connected between the dc link and the battery bank. To do this, the error between the RMS voltages of distinct phases is compared to their reference values, yielding three-phase error signals. This converter can able to work as buck during charging process and boost when required discharging of the battery [5]. Therefore, the bidirectional converter can maintain power balance through battery bank.

A power discrepancy between the load and the PV might create voltage fluctuations at the dc-link [4]. As a result, voltage at the dc-link influences the operation of a bidirectional DC to DC converter. A reference dc-link voltage signal is set using the under modulation technique based on the demand for AC voltage. The reference dc-link voltage is compared with actual voltage at dc-link to decide the action of charging or discharging process of the battery bank. As a result, energy management of the standalone system may be obtained using a bidirectional DC to DC converter with an effective control approach. The inverter can able to produce required voltage at PCC once stabilized the voltage at dc-link. However, majority operating load at PCC are single phase. These single phase loads leads unbalanced voltages at PCC. Hence, an effective inverter control is required to produce counter modulation indexes during unbalanced voltage at PCC to make them balanced. This study on a PV-Battery-based standalone power supply system presents a novel approach to energy management and inverter control in order to preserve power quality at PCC. These proposed methods can able to deliver quality power at PCC during all possible changes happened in the standalone system.

The following sections comprise the document. Section II contains a description of the standalone system with component modeling. Section III describes an energy management system based on the control of a DC to DC bidirectional converter. Section IV discusses the relevance of inverter control. MATLAB/Simulink based results are listed and discussed in Section-V. The conclusion and references are given at the end of the paper.

2. DESCRIPTION

A PV-Battery based standalone power supply system is considered in this paper to maintain power quality through proposed control schemes. Before presenting the model diagram of standalone system, detailed modeling of main components used in the standalone system

are discussed. Detailed mathematical modeling of various components is presented as follows:

A. PV power generation system [5]

Solar energy can be directly converted into electricity through PV panels by photoelectric effect. A single PV cell model is depicted in Fig. 1. A large number of PV cells must be connected in parallel and series to form a module that can provide a specific voltage and current. The PV array can be created by connecting few of PV modules in series to produce required voltage to operate loads. The fundamental mathematical expression used for modelling of a PV system is presented below.

$$I_{PV} = n_p I_{ph} - I_{rs} \left[\exp \left(\frac{q(V_{PV} + I_{PV} R_s)}{AKTn_s} \right) - 1 \right] - \frac{V_{PV} + I_{PV} R_s}{R_{sh}} \quad (1)$$

However, proper operating point should be identified to achieve the best utilization of PV system due to its nonlinear characteristics of power vs voltage as per curves depicted in Fig. 2. The best operating voltage point is considered as voltage corresponding to maximum power point (V_{mpp}). The location of V_{mpp} will vary according to solar irradiance. Therefore perturb and observe (P&O) mechanism is implemented to identify proper V_{mpp} during random changes in solar irradiance. This V_{mpp} signal will be given as reference voltage signal of boost converter to make it as MPPT converter of the PV system [13-15].

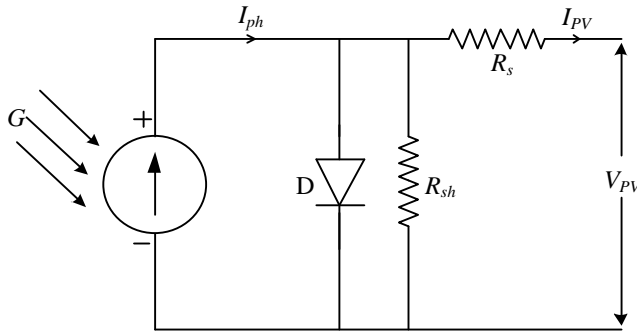

Fig. 1: Model diagram of a single PV cell.

The basic principle with eq.(2) is used to implement P&O algorithm and a feedback control loop helps to track the voltage to extract maximum power from PV system during any value of uniform irradiances.

$$V_{mpp}(k+1) = \Delta V \times \text{sign} \left(\frac{dP_{PV}}{dV_{PV}} \right) + V_{mpp}(k) \quad (2)$$

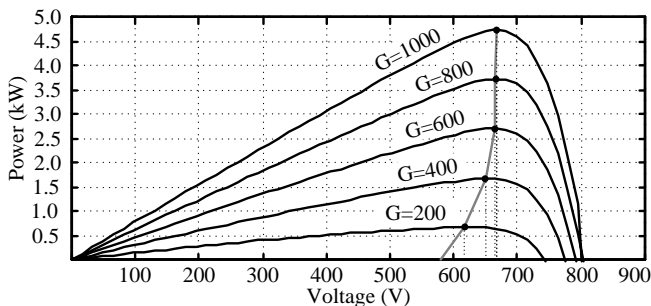

Fig. 2: MPPT identification under different solar irradiances.

B. Modelling of a generic battery bank

The battery bank is setup by connecting multiple batteries in the combination of series and parallel according to requirements of the standalone system. The mathematical approach on modeling of battery is attempted by references [4-5, 6-10]. A temperature based modeling of battery system is developed in this paper for achieving responses near to real time. Further a state of charge (SoC) is also incorporated to achieve dynamic behavior of the battery model. A controlled source constant voltage block is considered while doing modeling of the battery. The following fundamental equations are used to try a general model of the battery, and the associated block diagram is presented in Fig. 3.

$$E_m = E_{m0} - K_E(1 - SOC) \times (273 + \theta) \quad (3)$$

$$Q_e(t) = Q_{e_init} + \int_0^t -I_m(\tau) d\tau \quad (4)$$

$$I_p = V_{PN} G_{P0} \exp\left(\frac{V_{PN}}{V_{P0}(\tau_p^s + 1)} + A_p \left(1 - \frac{\theta}{\theta_f}\right)\right) \quad (5)$$

$$C(I, \theta) = \frac{K_c C_0 K_t}{1 + (K_c - 1) \left(I/I^*\right)^\delta}, K_t = LUT(\theta) \quad (6)$$

Where, $DOC = 1 - \frac{Q_e}{C(I_{avg}, \theta)}$; $SOC = 1 - \frac{Q_e}{C(0, \theta)}$,

$$\theta(t) = \theta_{init} + \int_0^t \left(\frac{P_s - (\theta - \theta_a)}{R_\theta} \right) \frac{1}{C_\theta} d\tau$$

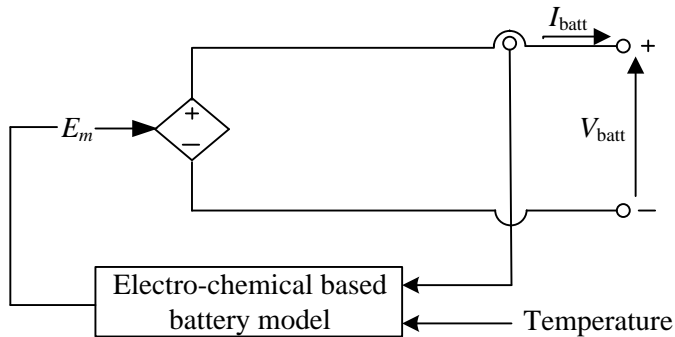

Fig. 3: Model diagram representation of a battery model.

C. Inverter and Distribution System

Generally the distribution power supply system compressed with a three phase system. Hence, a three phase inverter is employed between dc-link and PCC. Single phase loads are operated at PCC which consumes unbalanced load currents from inverter. Usually a small distribution lines are employed along with LC filter between inverter and PCC, hence these unbalanced currents caused unbalanced voltages at PCC. These unbalanced voltages create poor power quality and even becoming dangerous for three phase loads. Therefore, an effective control mechanism of inverter is proposed in this paper to supply good quality of power at PCC during even under unbalanced load scenario. The complete PV-Battery based electrical power supply standalone power system is depicted in Fig. 4. The MATLAB

model of a MPT algorithm is also depicted in Fig. 5. Remaining components are modeled by using [6-18].

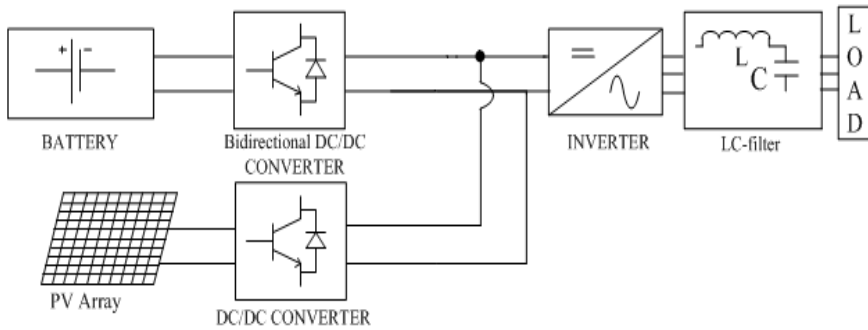

Fig. 4: Hybrid Stand-Alone Power Generation System based on PV.

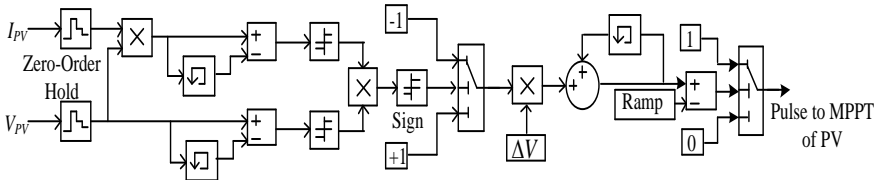

Fig. 5: P&O-based MPPT controller for PV system.

3. CONTROL OF DC VOLTAGE

The primary objective of the control mechanism in a bidirectional DC to DC circuit is to maintain voltage stability at the dc-link. Additionally, it ensures efficient energy management by accurately managing battery charging and discharging in order to address any power imbalances between the load and generation. Usually the second frequency oscillations will be imposed into voltage at dc-link due to operation of unbalanced load at PCC. These oscillations increase the heat across the terminals of the P system. A novel control method for bidirectional DC to DC circuit is adopted in this paper to suppress these oscillations. Figure 6 depicts the suggested control method of a DC to DC bidirectional converter for adjusting voltage at the dc-link..

The V_{dc} is filtered by a low pass filter to get the dc component (V_{dc0}), which is approximated by subtracting it from the oscillating component. The voltage at the dc-link is compared to its reference value to generate the reference battery current. Two PI controllers are employed in the suggested control approach to provide correct charging and discharging of the battery as well as oscillation suppression. First PI controller is used to produce reference current from the error ($V_{dc}^* - V_{dc}'$) to maintain voltage at dc-link at its reference value. The second PI controller is help to make oscillation to zero by comparing them with zero reference value i.e., ($0 - V_{dc0}$). To create the final reference battery current (I_{bat}^*), Both PI controller outputs are combined. This reference current is then compared to the actual battery current to generate the needed pluses for (Q1 & Q2) using a hysteresis loop.

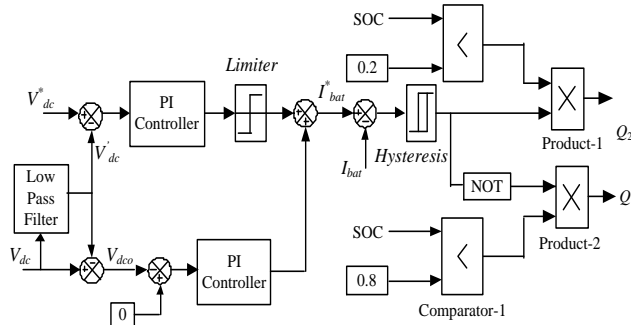

Fig. 6: Proposed control method of bidirectional circuit.

4. CONTROLLER OF INVERTER

An inverter control approach is developed to generate different modulation indices in order to maintain balanced voltage at the PCC during unbalanced load currents. As already mentioned, majority loads operated at PCC supplied by inverter are in unbalanced nature. Due to unbalanced load being connected at PCC, which causes unbalanced voltages at PCC since unbalanced drops across LC filter. Hence, it is mandatory to produce counter modulation indexes of the inverter through proposed control method of the inverter to make it balanced voltages at PCC. To do this, the error between the RMS voltages of distinct phases is compared to their reference values, yielding three-phase error signals.. These error signals are further treated as inputs of corresponding PI controllers to produce counter modulation indexes. The generated modulation indexes of each phase is multiplied by an unit sine wave to produce the reference voltage signals for generating pulses through an PWM strategy. Figure 7 illustrates the suggested inverter control technique for offsetting unbalanced voltages.

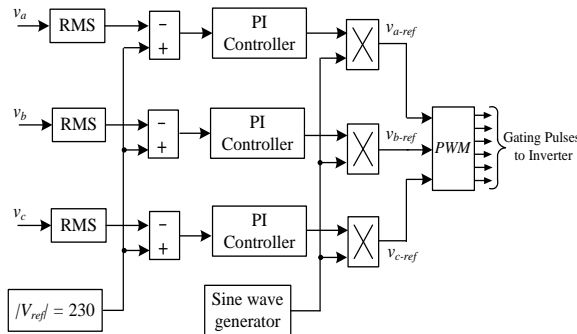

Fig. 7: Inverter Control method.

5. RESULTS

A standalone power supply system powered by PV-Battery presented in Fig. 4 is simulated using MATLAB/Simulink platform to present results. Various responses are observed under different operating conditions. Various rating of components used in standalone system are obtained from [19-23]. Results are carried out and presented under below cases.

Case-1: under meteorological changes.

The standalone system is tested under changes in solar irradiance and load. High load is connected at PCC at $t=2.0$ sec. and irradiance is increased at $t=3.0$ sec. Responses of

voltages at dc-link and PCC are depicted in Fig. 8(a) and (b) respectively. From Fig. 8, there are no much changes in both voltages. A constant RMS voltage is maintaining at PCC during above changes. It seems the power quality is achieved at PCC through proposed control methods. For a better visualization, instantaneous voltage and current of a line is presented in Fig. 9(a) and (b) accordingly. From these results, observed that the control schemes are giving satisfactory performances during changes in source and load.

Case-2: Considering unbalanced load.

An unbalanced load is considered at PCC by connecting single phase loads with line current of (Fig. 10 (a)) as: $i_{ia} = 3.53\text{A}$; $i_{ib} = 9.55\text{A}$; $i_{ic} = 8.45\text{A}$. Under this situation, the RMS voltages at PCC become unbalanced due to unequal drops across each phase with normal control of inverter. However, the proposed control method of the inverter helps to maintain balanced voltages at PCC by producing counter modulation indexes. Corresponding line voltages after compensation through proposed method is shown in Fig. 10(b). Balanced voltages are obtained by proposed control method, hence it is stated that the proposed method can improve the quality of the power at PCC during unbalanced load conditions. This happened by producing different modulation index for each phase of the inverter.

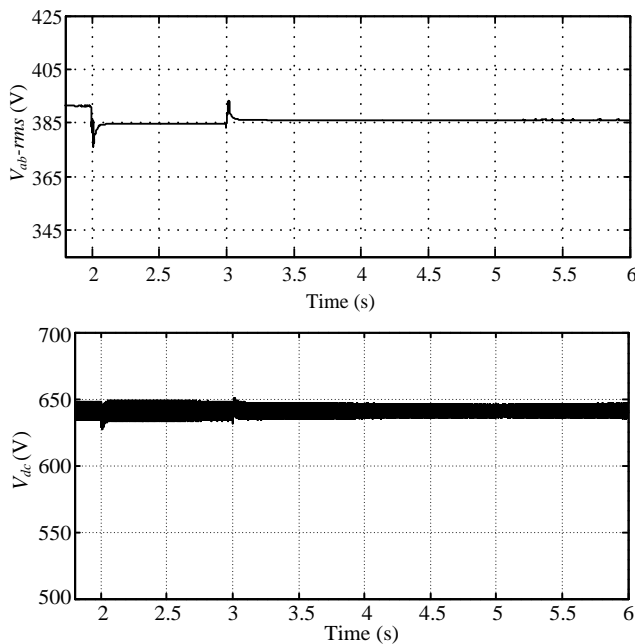

Fig. 8: Voltages at a) PCC RMS, b): dc-link.

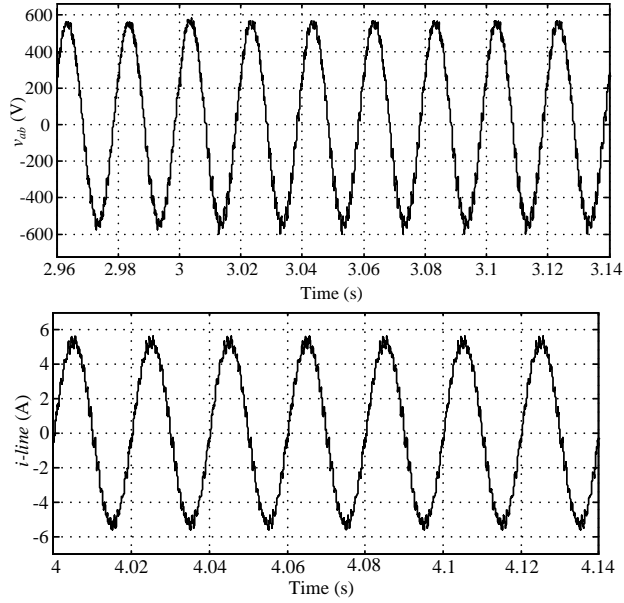

Fig. 9: instantaneous waveforms of a) line-line voltage, b) current flowing through line.

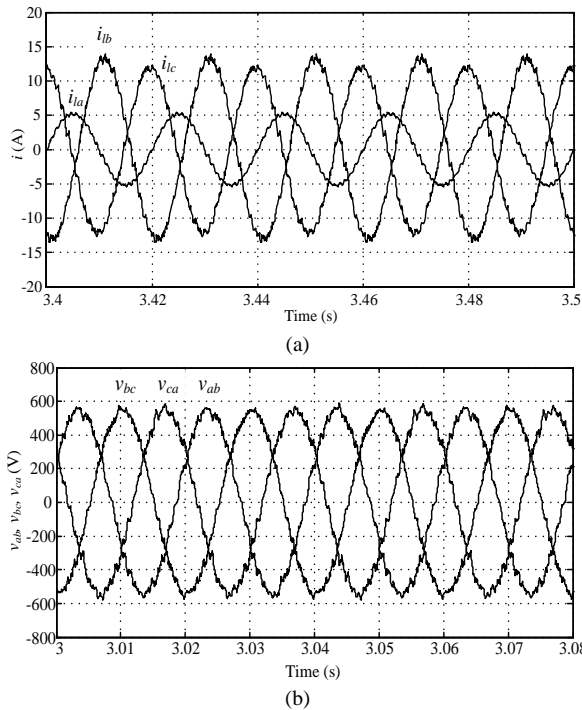

Fig. 10: a) Unbalanced currents at PCC, b) balanced line-line voltages at PCC.

6. CONCLUSION

Hybrid PV-Battery powered standalone power supply system is presented in this paper for improving power quality. A bidirectional circuit is integrated between the dc-link and

battery to efficiently handle the fluctuations and discharge. Novel control schemes are implemented on bidirectional converter and inverter to achieve both energy management systems as well as quality power supply at PCC. A boost converter operated by a MPPT algorithm is integrated to PV system to extract maximum energy. The proposed control scheme of the three phase inverter is designed in such a fashion that, to maintain balanced voltages at PCC during unbalanced load scenario. Detailed modeling of various components is also presented in this paper. Extensive results using MATLAB/Simulink are presented under various operating conditions to enhance the significance of proposed method.

References

- [1] Malla, Siva Ganesh, Malla, Jagan Mohana Rao, Malla, Priyanka, Ramasamy, Sreekanth, Doniparthi, Satish Kumar, Sahu, Manoj Kumar, Subudhi, Pravat Kumar and Awad, Hilmy. "Coordinated power management and control of renewable energy sources based smart grid" *International Journal of Emerging Electric Power Systems*, vol. 23, no. 2, 2022, pp. 261-276. <https://doi.org/10.1515/ijeeps-2021-0113>
- [2] H. Polinder, F. F. A. van der Pijl, G. J. de Vilder, P. J. Tavner, "Comparison of direct-drive and geared generator concepts for wind turbines", *IEEE Transactions on Energy Conversion*, vol., 21, no. 3, pp. 725-733, Sept. 2006.
- [3] T. F. Chan, L. L. Lai, "Permanent-magnet machines for distributed generation: a review", *Proc. 2007 IEEE power engineering annual meeting*, pp. 1-6.
- [4] C N Bhende, S Mishra, SG Malla, "Permanent magnet synchronous generator-based standalone wind energy supply system", *IEEE Transactions on Sustainable Energy*, vol. 2, no. 4, pp. 361-373, 2011.
- [5] S G Malla, C N Bhende, "Voltage control of stand-alone wind and solar energy system", Elsevier, *International Journal of Electrical Power & Energy Systems*, vol. 56, pp. 361-373, 2014.
- [6] Siva Ganesh Malla, D Jaya Deepu, D Pavan Kumar, "Design and experimental setup of a backup battery as a source to mobile phone battery", *International Conference on Electrical, Electronics, and Optimization Techniques (ICEEOT)*, pp. 2815-2822, 3rd Mar 2016, India.
- [7] Bose B.K, *Power Electronics and Motor Drives*, Academic Press, Imprint of Elsevier, 2006.
- [8] B.L. Theraja, A.K. Theraja, *A Textbook of Electrical Technology*, Vol.2.
- [9] Jagan Mohana Rao Malla and Siva Ganesh Malla, "Three level diode clamped inverter for DTC-SVM of induction motor", *Joint International Conference on Power Electronics, Drives and Energy Systems (PEDES) and Power India*, pp. 1-6, 20-23 Dec. 2010.
- [10] B. K. Bose, *Expert system, fuzzy logic, and neural network applications in power electronics and motion control*, *Proc. IEEE*, vol. 82, pp. 1303-1323, August 1994.
- [11] Siva Ganesh Malla, JMR Malla, D Jaya Deepu, D Pavan Kumar, "Performance evaluation of DSTATCOM with 9-level GTO converter", *International Conference on Electrical, Electronics, and Optimization Techniques (ICEEOT)*, pp. 4392-4396, 3rd Mar 2016, India.
- [12] S G Malla, M.Hema Lata Rao, J. M. R. Malla, R. R. Sabat, J. Dadi and M M Das, "SVM-DTC Permanent magnet synchronous motor driven electric vehicle with bidirectional converter", *International Multi-Conference on Automation, Computing, Communication, Control and Compressed Sensing (iMac4s)-2013*, pp. 742-747, 22-23 March 2013.

- [13] Arun Ghosh, S G Malla and C N Bhende, "Small-signal modelling and control of photovoltaic based water pumping system", *ISA Transactions*, Vol. 57, pp. 382-389, July 2015
- [14] S G Malla, C N Bhende, "Enhanced operation of stand-alone "Photovoltaic-Diesel Generator-Battery" system", *Electric Power Systems Research*, Vol. 107, pp. 250-257, Feb. 2014.
- [15] C N Bhende, S G Malla, "Voltage control of stand-alone" Photovoltaic-Diesel Generator-Battery" system", 40th Annual Conference of the Industrial Electronics Society, IECON 2014, pp. 2292-2297, 29 Oct to 1 Nov. 2014.
- [16] S G Malla, C N Bhende, "Study of Stand-Alone Microgrid under Condition of Faults on Distribution Line", *International Journal of Emerging Electric Power Systems*, Vol. 15, Issue 5, pp. 501-512, Oct. 2014.
- [17] C N Bhende, S G Malla, "Novel control of photovoltaic based water pumping system without energy storage", *International Journal of Emerging Electric Power Systems*, Vol. 13, Issue 5, Nov. 2012.
- [18] S. G. Malla, C N Bhende, S. Mishra, "Photovoltaic based water pumping system", *International Conference on Energy, Automation, and Signal (ICEAS)*, pp. 1-4, 28-30 Dec. 2011.
- [19]. U. R. Muduli, A. R. Beig, K. A. Jaafari, K. A. Hosani, A. S. Al-Sumaiti and R. K. Behera, "Dual Motor Power Sharing Control for Electric Vehicles With Battery Power Management," in *IEEE Transactions on Industrial Electronics*, doi: 10.1109/TIE.2023.3236096.
- [20]. Priyanka Malla, "Novel Control Technique for MPPT of PV Standalone System with TSK Fuzzy controller", *International Journal of New Technologies in Science and Engineering (IJNTSE)*, Vol. 8, Issue. 8, pp. 1-7, Aug. 2022.
- [21]. J. K. Singh, K. A. Jaafari, R. K. Behera, K. A. Hosani and U. R. Muduli, "Faster Convergence Controller With Distorted Grid Conditions for Photovoltaic Grid Following Inverter System," in *IEEE Access*, vol. 10, pp. 29834-29845, 2022, doi: 10.1109/ACCESS.2022.3159476.
- [22]. O N Chandrasekhar, "Modified Grey Wolf Optimization Algorithm for MPPT of PV System under Partial Shading Conditions", *International Journal of New Technologies in Science and Engineering (IJNTSE)*, Vol. 8, Issue. 5, pp. 1-6, May. 2022.
- [23]. A. Dash, D. P. Bagarty, P. K. Hota, U. R. Muduli, K. A. Hosani and R. K. Behera, "Performance Evaluation of Three-Phase Grid-Tied SPV-DSTATCOM With DC-Offset Compensation Under Dynamic Load Condition," in *IEEE Access*, vol. 9, pp. 161395-161406, 2021, doi: 10.1109/ACCESS.2021.3132549.