

A Fuzzy Inference Model for Efficient Power Stabilization Model in PV Systems

¹Dr. Shailesh Madhavrao Deshmukh, and ²Ravi Prakash Mahobia

^{1,2}*Assistant Professor, Department of Electrical, Kalinga University, Naya Raipur, Chhattisgarh, India.*

Abstract: The power stabilization in photovoltaic systems is well studied. There exist number of approaches in stabilizing the output power of PV systems. The most approaches concern about the input power and residual energy of capacitors. Still they suffer to achieve higher performance in power stabilization. To handle this issue, an efficient Fuzzy inference based Power stabilization model (FIPSM) is presented in this paper. The model is focused on utilizing residual energy on different circuits and avoiding higher drain of energy on any of the circuit. The model fabricated with MOFSET device in each circuit which monitors the input and output voltage of any circuit. As the model has number of circuits framed in serial connection, the method generates fuzzy rules based on the conditions of different circuits for different input voltage with output voltage required. At each duty cycle, the method reads the input voltage and identifies set of circuits were in sleep or charging mode. With the list of circuits, the method computes the Fuzzy Inference Voltage Stabilization Support (FIVSS) for various circuits. Based on the value of FIVSS, the method identifies a unique or a subset of circuits to support stabilization. The proposed model improves the performance of power stabilization in photovoltaic systems.

Keywords: PV Systems, Power Stabilization, Fuzzy Inference Model, FIPSM, FIVSS.

1. Introduction:

The increased use of electricity challenges the power generation units and increases the cost of power generation. In general, the electric power has been generated with some sources like water, atomic, wind and sunlight. The resources other than photovoltaic are scarce in nature and it won't be available for long time. The only energy available throughout the year is the photovoltaic power. The photovoltaic power can be generated from sunlight by installing set of panels where each has some units to convert the heat into electric energy. By installing number of panels in serial and parallel connection,

¹ku.shaileshmadhavraodeshmukh@kalingauniversity.ac.in

²ku.raviprakashmahobia@kalingauniversity.ac.in

they can be stored in set of inverters. The power stored in the inverted can be used at the time when there is poor incoming energy.

The photovoltaic system is designed to support different electric systems which require steady electric voltage. The electric power received by the system will not be steady and there will be different fluctuation. However, the electric system would require steady voltage for the smooth functioning. To support this, the PV systems are attached to the systems which support the steady current flow.

The pv systems comes with number of circuits integrated with MOFSET which record the available residual voltage and conditions of the circuit. However, the performance of PV systems is depending on the selection of circuit for the support of steady output voltage. In general, the methods selects the random circuit to support the voltage flow, which leads to the missing case of circuit with higher residual voltage being not selected and the circuit with less voltage has been selected frequently and lead to the condition of drain. This affects the performance of the entire model and suffers with poor stabilization process. Similarly, when you select a most residual energy circuit for the support, then the rest of the circuits will be idle and in charging mode. What happens when higher voltage is obtained, then the circuits will not be charged and the voltage will be lost. This also affect the performance of the entire model.

By considering all these issues, an efficient Fuzzy Inference Model based Power Stabilization scheme is presented in this paper. The model focused on the selection of circuit for both delivery and charging according to the residual voltage on different capacitors of the circuit and inverters. By doing so, the voltage loss will be reduced and the power stabilization performance can be improved. The proposed model monitors the incoming voltage and identifies set of circuits which were idle at the previous duty cycle. Based on that, the method computes the value of Fuzzy inference voltage stabilization support (FIVSS) for all the circuits identified. Based on that a subset of circuits are selected for delivery and subset of circuits will be selected for charging mode. By doing so, the method would achieve higher power regulation and stabilization. The detailed working of the model is presented in the section 3.

2. **Related Works:**

The problems of power stabilization in PV systems are approached with various techniques and this section details some of the methods around the problem.

A grid connected solar photovoltaic with wind energy (PV-WE) is presented in [1], which is integrated with energy storage system and electric vehicles. A comprehensive modeling and analysis is presented towards stabilization of PV based microgrid clusters [2]. Also, a local adaptive dynamic droop control mechanism of the voltage-source PV system is developed.

A two-stage optimization of superconducting magnetic energy storage (SMES) is presented in [3], which is integrated into hybrid wind/photovoltaic (PV) generators considering the state of charge (SOC) control for stabilizing voltage and power fluctuations. A dynamic autonomous PV-based MG including PV panels and DC-link is presented in [4], which produces dynamic performance. The characterization of voltage stabilization of residential PV inverters is analyzed in detail in [5].

The author characterizes the dynamic interactions between parallel PV based VSC system in [6], which consider the dynamics of PV source, strength of grid and variation of operation point and other control parameters. In [7], the author analyze the effect of dynamic properties of PV generator over the stability of current source inverter based PV system.

A multimode control for PV-STATCOM operation of a photovoltaic (PV) solar plant is presented in [8], which prevents the instability of induction motors which are located in a remote location.

To compensate the harmonics of contaminated currents, a parallel combination of nonlinear load and a photovoltaic (PV) inverter with adaptive quantum normalized-least mean fourth (q XE-LMF) filter is proposed in [9]. A power decoupled current source inverter (PD-CSI) is presented in [10], which compensate the reactive power to regulate the exact voltage.

A multivariable T-S fuzzy decision approach is employed in [11], towards provide adaptive voltage distribution on PV battery. A complete state-space linearized model is presented in [12], which consider different conditions of operation to produce maximum power support. A improved Finite control set-model predictive control (I-FCS-MPC) model is presented in [13], which consider the DC-link dynamics of PV generation for voltage source converter (VSC). A current sensorless delay-based controller for the closed-loop stabilization of a photovoltaic system under an MPPT scheme using a boost dc/dc converter is presented in [14][15].

3. Fuzzy Inference Based Power Stabilization Model for PV systems:

The proposed model monitors the incoming voltage at all the duty cycle. Also, the method maintains the history of circuits with their condition and voltage conditions. Using them, the method identifies the set of circuits which are in the charging mode in the previous cycle. For the identified list of circuits, the method computes the value of Fuzzy inference voltage stabilization support (FIVSS). Based on the value of FIVSS, the method identifies a set of circuits for the delivery conditions and set of circuits for the charging condition. The value of FIVSS is measured according to the rule set available. The fuzzy rules are generated according to the incoming voltage and required output voltage. By maintaining such voltage range and residual voltage of different capacitor and inductor, the method computes the value of FIVSS for any circuit. By choosing the circuits in this way, it support the power stabilization to be done in efficient way.

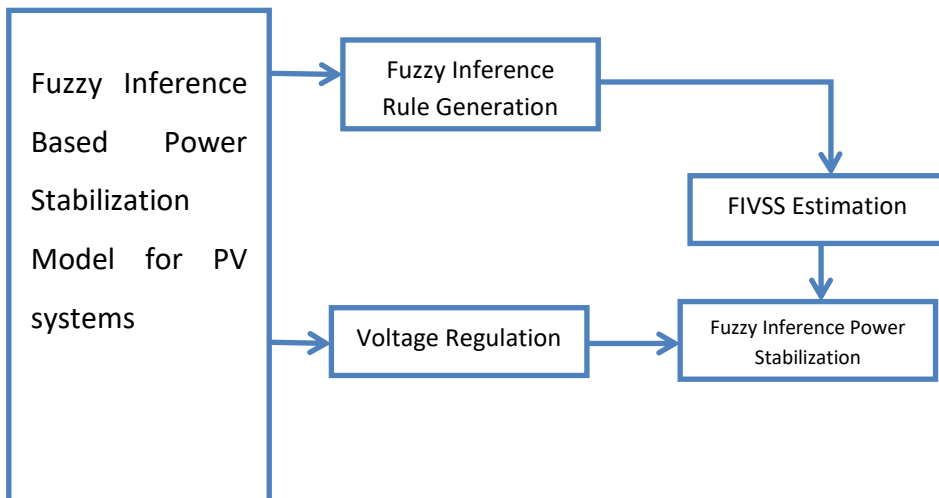

Figure 1: Architecture of proposed FIPSM model

The working of the proposed FIPSM based power stabilization model is presented in Figure 1, where the functions of the model are detailed in this section.

Fuzzy Inference Rule Generation:

The proposed model works according to the fuzzy inference rule generated from the traces. It maintains set of trace about the voltage flow and residual energy of various circuits. The method uses the trace to compute the inference rule. To perform this, the method use the list of input voltage and output voltage. For any input voltage, the method computes the range of residual voltage in any circuit. If the circuit has two capacitor and inductors, then it computes the range values of voltage to be available in any circuit. By computing minimum and maximum value of ranges the method generates the fuzzy rule.

Algorithm:

Given: Voltage Trace VT, output voltage Ov.

Obtain: Fuzzy inference rule FIR

Start

Read VT and Ov.

Identify set of circuits $C_s = C_s \cup (VT(i).CircuitId \ni C_s)$

$$i = 1$$

$$Ov$$

Generate Input voltage set $Ivs = Ivs \cup (v * 10)$

$$v = \left(\frac{Ov}{2}\right)$$

For each voltage v in Ivs

$$\text{Compute min voltage} = \frac{(Ov-v)}{2}$$

$$\text{Compute max voltage} = (Ov-v)$$

Generate rule $r = \{\text{min voltage, max voltage, min voltage, max voltage}\}$

Add to rule set $FIR = FIR \cup r$

End

Stop

The fuzzy inference rule generation algorithm computes the min and max voltage values for different input voltage generated to generate the fuzzy inference rule. Generated rule set is used to perform power stabilization.

FIVSS Estimation:

The FIVSS is the measure which represents the suitability of any circuit in supporting efficient power stabilization in PV systems. It has been measured based on the incoming voltage, residual voltage in the capacitor and inductor present in the circuit. Using all these values, the method computes the value of FIVSS. Estimated FIVSS value has been used to perform power stabilization in the next stage.

Algorithm:

Given: Input voltage Iv, Circuit C, Output Voltage Ov, Fuzzy Inference rule set FIR

Obtain: FIVSS.

Start

Read IV, C, FIR and OV.

$$Size(FIR)$$

Find optimal rule sets $Ors = \sum_{i=1}^{Size(FIR)} FIR(i).Iv \mp 5 (Iv)$

$$i = 1$$

For each rule r

Compute

FIVSS

=

$$\frac{\text{Count}(C(i).voltage < r(\text{min}, \text{max}) >)}{i=1}^{\text{size}(Capacitor)} \times \frac{\text{Count}(C(i).voltage < r(\text{min}, \text{max}) >)}{i=1}^{\text{size}(Inductor)}$$

End

$$FIVSS = \frac{\sum FIVSS}{size(Ors)}$$

Stop

The above algorithm computes the value of FIVSS for any circuit according to the different fuzzy inference rule available. Estimated value of FIVSS has been used to perform power stabilization.

Fuzzy Inference Power Stabilization:

The fuzzy inference power stabilization algorithm reads the voltage trace and monitors the incoming voltage. At each duty cycle, based on the incoming voltage, the method identifies the set of circuit were in the charging mode in the previous cycle. With the circuits identified the method estimates FIVSS value for the circuits. Based on the value of FIVSS, the most valued k circuits are selected to perform regulation and rests of them are triggered to charging mode.

Algorithm:

Given: Voltage Trace VT, Fuzzy Inference Rule FIR.

Obtain: Null

Start

Read VT and FIR.

While true at each duty cycle

Receive incoming voltage Iv.

Find idle circuits $Ic = \sum_{i=1}^{size(VT)} VT(i).Circuit \text{ where } VT(i).State == Idle$

For each circuit C

FIVSS = Estimate FIVSS (C, FiR)

End

Circuits $Cs = \sum_{i=1}^{Size(Ic)} Ic(i) > (Max(FIVSS) \times \frac{6}{8})$

Trigger circuits of CS to discharge.

Trigger others to charging.

End

Stop

The Fuzzy inference power stabilization model estimates the FIVSS value for various circuits and trigger a subset of circuits to discharge and rest of them to charging.

4. Results and Discussion:

The proposed Fuzzy inference based power stabilization model has been implemented and evaluated for its performance. The performance of the model has been compared with the rest of the models.

Parameter	Value
Tool Used	Simulink
Number of circuits	20
Number of input volts	10
Number of output volts	1

Table 1: Experimental Details

The experimental details considered for the performance evaluation is presented in Table 1.

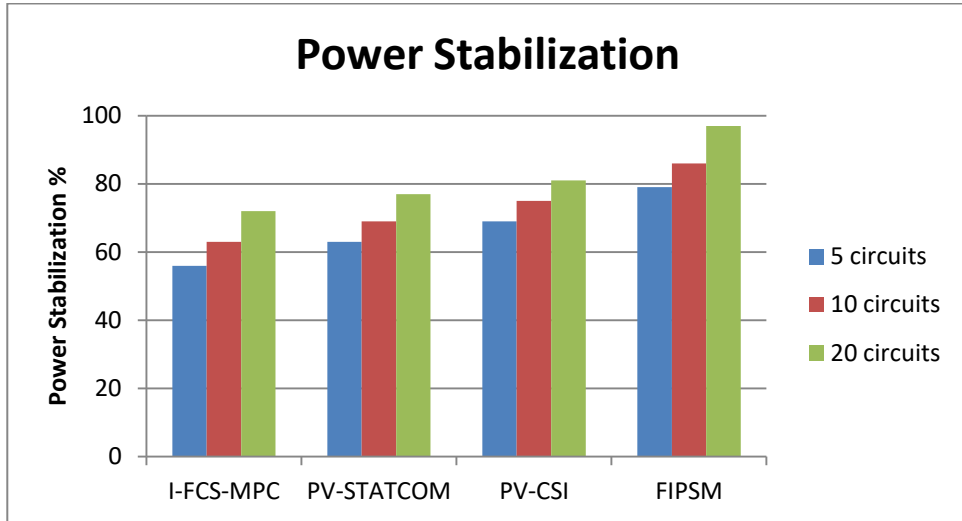

Figure 2: Power Stabilization

The performance of model in power stabilization is measured and compared with the other models. The proposed FIPSM model introduces higher performance than others.

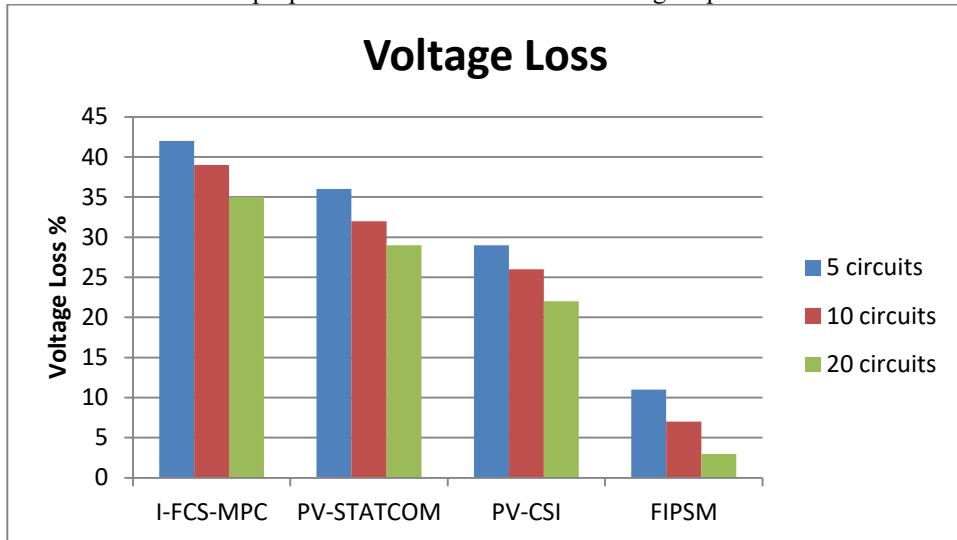

Figure 3: Voltage Loss

The voltage loss introduced by various methods are measured and compared in Figure 3. The FIPSM method introduces less voltage loss than others.

5. Conclusion:

An efficient Fuzzy inference based power stabilization model is presented for the support of PV systems. The method monitors the incoming voltage and identifies a set of idle circuits. With the input voltage, the method computes the value of FIVSS for different circuits identified. According to the value of FIVSS, the method identifies a subset of circuits with moderate FIVSS value. Such circuits are triggered to discharge and rest is triggered to charge. The proposed model improves the performance of power stabilization with less voltage loss.

6. References:

1. K. Sarita et al., "Power Enhancement With Grid Stabilization of Renewable Energy-Based Generation System Using UPQC-FLC-EVA Technique," in *IEEE Access*, vol. 8, pp. 207443-207464, 2020, doi: 10.1109/ACCESS.2020.3038313.
2. Z. Zhao, P. Yang, Y. Wang, Z. Xu and J. M. Guerrero, "Dynamic Characteristics Analysis and Stabilization of PV-Based Multiple Microgrid Clusters," in *IEEE Transactions on Smart Grid*, vol. 10, no. 1, pp. 805-818, Jan. 2019, doi: 10.1109/TSG.2017.2752640.
3. J. Pahasa and I. Ngamroo, "Two-Stage Optimization Based On SOC Control of SMES Installed in Hybrid Wind/PV System for Stabilizing Voltage and Power Fluctuations," in *IEEE Transactions on Applied Superconductivity*, vol. 31, no. 8, pp. 1-5, Nov. 2021, Art no. 5401205, doi: 10.1109/TASC.2021.3089119.
4. Z. Zhao et al., "Modeling, Oscillation Analysis and Distributed Stabilization Control of Autonomous PV-based Microgrids," in *CSEE Journal of Power and Energy Systems*, vol. 9, no. 3, pp. 921-936, May 2023, doi: 10.17775/CSEEJPES.2021.07570.
5. T. Kaewnukultorn, S. B. Sepúlveda-Mora and S. Hegedus, "Characterization of Voltage Stabilization Functions of Residential PV Inverters in a Power Hardware-in-the-Loop Environment," in *IEEE Access*, vol. 10, pp. 114802-114813, 2022, doi: 10.1109/ACCESS.2022.3217472.
6. M. M. Rahman and Y. A. -R. I. Mohamed, "Interaction Dynamics and Active Suppression of Instability in Parallel Photovoltaic Voltage-and Current-Source Converters Connected to a Weak Grid," in *IEEE Open Journal of Power Electronics*, vol. 4, pp. 395-414, 2023, doi: 10.1109/OJPEL.2023.3275610.
7. M. M. Rahman and Y. A. -R. I. Mohamed, "Dynamic Analysis and Active Stabilization of a Utility-Scale Grid-Connected Current-Source Inverter-Based PV System Considering Source Dynamics," in *IEEE Transactions on Power Systems*, vol. 37, no. 6, pp. 4590-4604, Nov. 2022, doi: 10.1109/TPWRS.2022.3148983.
8. R. K. Varma, S. Mohan and J. McMichael-Dennis, "Multimode Control of PV-STATCOM for Stabilization of Remote Critical Induction Motor," in *IEEE Journal of Photovoltaics*, vol. 10, no. 6, pp. 1872-1881, Nov. 2020, doi: 10.1109/JPHOTOV.2020.3013975.
9. N. Patel, A. Kumar, H. R. Pota, R. C. Bansal and N. Gupta, "Adaptive qXE-LMF Filter for Improving Power Quality Using Grid-Supporting Photovoltaic System," in *IEEE Systems Journal*, vol. 17, no. 2, pp. 2709-2720, June 2023, doi: 10.1109/JSYST.2023.3241346.
10. M. -H. Wang, Y. He, Y. Jia and Z. Xu, "A Power-Decoupled Current-Source Inverter for PV Energy Harvest and Grid Voltage Regulation," in *IEEE Transactions on Industrial Electronics*, vol. 68, no. 10, pp. 9540-9549, Oct. 2021, doi: 10.1109/TIE.2020.3026264.
11. Wu, G., Liu, Z., Yao, L., Xu, Z., & Wang, W. (2013). A Fuzzy-based Trust Management in WSNs. *Journal of Internet Services and Information Security*, 3(3/4), 124-135.
12. M. A. K. Magableh, A. Radwan and Y. A. -R. I. Mohamed, "Dynamic Stabilization of a Centralized Weak Grid-Tied VSC System Considering PV Generator Dynamics," in *IEEE Transactions on Power Systems*, doi: 10.1109/TPWRS.2023.3262811.
13. Z. Zhao et al., "An Improved FCS-MPC Strategy for Low-Frequency Oscillation Stabilization of PV-Based Microgrids," in *IEEE Transactions on Sustainable Energy*, doi: 10.1109/TSSTE.2023.3259204.
14. J. -E. Hernández-Díez, C. -F. Méndez-Barrios, S. -I. Niculescu and E. Bárcenas-Bárcenas, "A Current Sensorless Delay-Based Control Scheme for MPPT-Boost

- Converters in Photovoltaic Systems," in IEEE Access, vol. 8, pp. 174449-174462, 2020, doi: 10.1109/ACCESS.2020.3024566.
15. Giliberto, M., Arena, F., & Pau, G. (2019). A fuzzy-based Solution for Optimized Management of Energy Consumption in e-bikes. *Journal of Wireless Mobile Networks, Ubiquitous Computing, and Dependable Applications*, 10(3), 45-64.