

Novel control of Multi Motor Driven Photovoltaic (PV) based Water Pumping System with HIL

Kalyan Acharjya, Mohit Kumar Sharma, Febin Prakash and Kuldeep Singh Kulhar

Kalyan Acharjya, Assistant Professor, Maharishi School of Engineering & Technology, Maharishi University of Information Technology, Uttar Pradesh, India, Email Id- kalyan.acharjya@gmail.com

Mohit Kumar Sharma, Assistant Professor, Electrical Engineering, Vivekananda Global University, Jaipur, India, Email Id-mohit.kumar.sharma@vgu.ac.in

Febin Prakash, Assistant Professor, Department of Computer Science and Information Technology, Jain (Deemed to be University), Bangalore, India, Email Id-febin.prakash@jainuniversity.ac.in

Kuldeep Singh Kulhar, Professor, Civil Engineering, Vivekananda Global University, Jaipur, India, Email Id-k.singh@vgu.ac.in

Abstract: Photovoltaic (PV) based water pumping systems driven by induction motors are used for many applications recently. Using of batteries for power backup can increase the overall system cost as well as required daily maintenance. Hence, the designing of a water pumping system without using battery backup is very important aspect when power supplied by PV panels. N efficient energy management system is developed in this paper and compared the response with various conditions. Hardware-in the-Loop (HIL) based results are incorporated in results section along with Simulink results to validate the proposed configuration. Two different control schemes based on power and voltages are proposed in this paper with the help of vector control of induction motor. Moreover the control scheme is implemented to operate identical multi motors. The seamless control technique is implemented to switched ON second motor based on availability of power from PV system.

Keywords: Water pumping system, Photovoltaic, MPPT, HIL.

Corresponding Author: k.singh@vgu.ac.in

1. INTRODUCTION

Water pumping systems (WPSs) are playing a significant role in society for drinking, agriculture, industrial and personal usages. A pump is required to lift the water from underground. Hence either electrical motor or diesel generators are necessary to drive the pump. Usually diesel generators are harmful to nature due to exhibits carbon products into air. However, supplying the electricity through utility grid may not be possible every time in every place especially in rural areas. Under such circumstances, renewable energy sources can be an often solution to provide sufficient electricity to run electric motor to drive the pump as well as can be an eco-friendly to the nature. Photovoltaic (PV) panels based power generation is simple and easily can setup in many places. Further, among various motors the induction motor (IM) is very economical and affordable by many formers. In [1, 2], authors were proposed a PV operated WPS driven by a dc motor. However, among many types of motors, use of IMs for water pumping is an attractive proposal due to absence of commutator and brushes which provide maintenance-free operations as well as reliability [3-4]. Among several types of pumps available, centrifugal pumps are commonly used for WPS [2].

The PV system should be operated at maximum power point (MPP) location to exhibits its better efficiency. Therefore a circuit should be employed to work as maximum power point tracking (MPPT) device on PV system [5-6]. In [5], authors proposed a WPS with battery storage and dc-dc converter for MPPT. The flexible operation can be obtained through battery storage, however, it increases the overall cost of the system by 10%-50% depending upon the size and type of batteries [7]. In the similar way, using an extra dc to dc converter for MPPT of PV system can increase system cost and occupy more place due to its size. Therefore, our aim is to implement a PV fed WPS driven by IM without batteries and dc-dc converter without losing its flexible and MPPT operation. Two methodologies are presented one is with battery storage {shown in Fig. 1(a)} and one is without storage {shown in Fig. 1(b) and (c)}. In case of without storage system, two control schemes are implemented, one is based on power control {Fig. 1(b)} and another is based on voltage control {Fig. 1(c)}. In Fig. 1(c), inverter itself regulates the dc-link voltage at MPPT value, hence no extra dc-dc converter required for MPPT. The schematic shown in Fig. 1(c) preferable over Fig. 1(a) and (b) for three reasons:

- System proposed in Fig. 1(c) does not require any dc-dc converter for MPPT and inverter can be used for the same.
- System in Fig. 1(c) requires measure of dc-link voltage (V_{dc}), while in Fig. 1(a) and (b) requires measure of PV and load powers.
- System does not have any storage devices, so it is a cost effective system.

The MATLAB simulation is done to host in OPAL-RT module. The hardware-in-loop (HIL) based results are presented in support of theory. The HIL is implemented with two units of real-time digital simulator (RTDS) manufactured by 'OPAL-RT Technologies'. This has been carried out with an aim to develop a near realistic control scheme that can be used upfront by the industry.

2. MPPT METHOD

The operating voltage of PV unit is very important to harvest maximum energy. This operating voltage should be regulated as per power vs voltage curves where a unique maximum power at a particular voltage (called as V_{mpp}). Fig. 2(a) depicted the characteristics of a PV module. Maximum power point trackers (MPPTs) are, therefore, employed to track the peak power and convey it to the load at all times. MPPT is basically a circuit whose regulate the dc-link voltage of PV corresponding to V_{mpp} , [8-9].

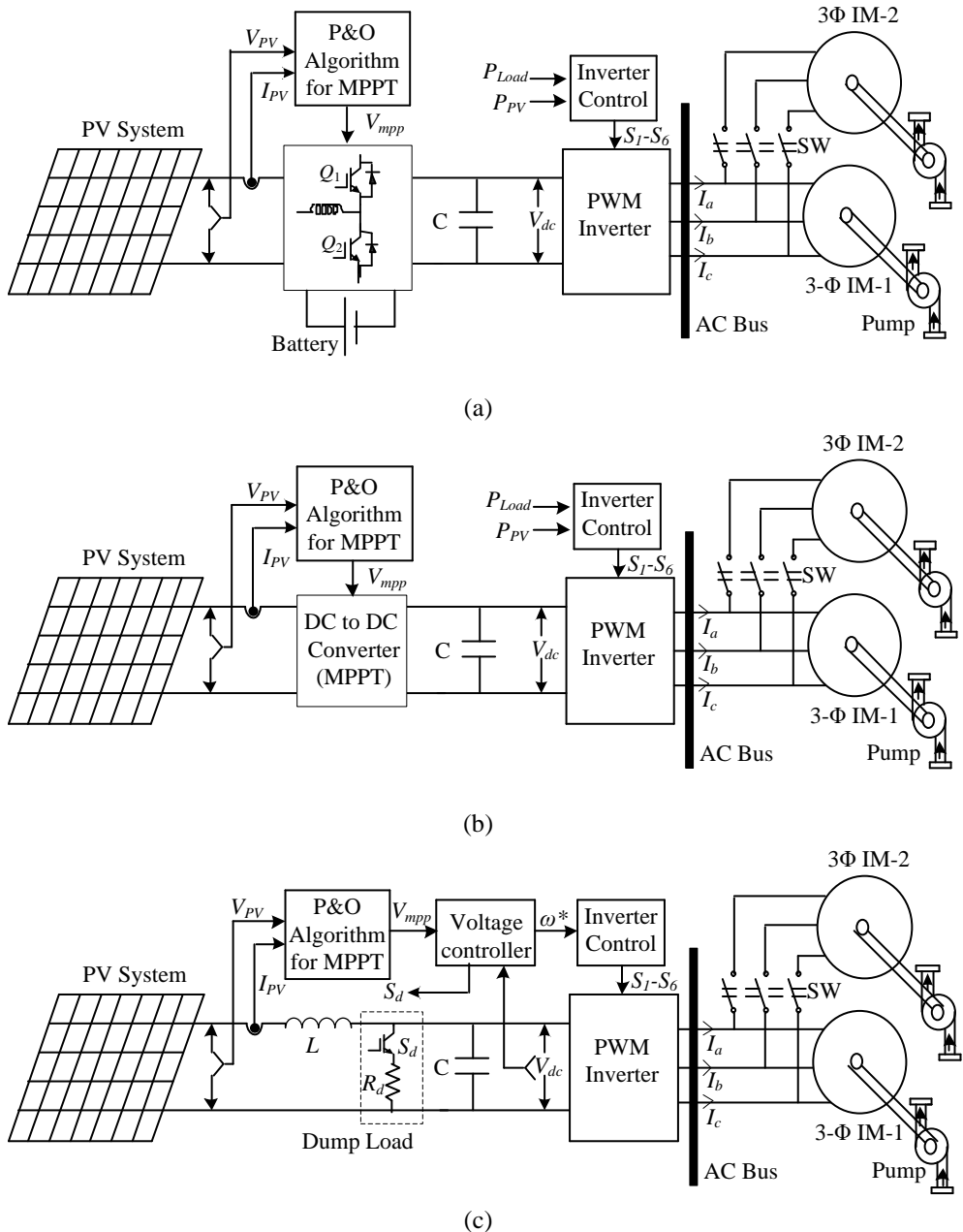

Fig. 1: PV based water pumping system, (a) with energy storage, (b) control based on power, (c) control based on voltage.

In case of power based control (Fig. 1(a) and (b)), the controller is based on comparison of PV power and load power (power at AC bus). Power generated from PV unit may vary from zero to maximum rating. Hence, in order to control the dc-link voltage, the physical MPPT converter (i.e, dc-dc converter) is required for regulating the dc-link voltage. In case of battery storage system, bidirectional converter regulates the dc-link voltage by acting as MPPT also. However, in case of voltage based controller (Fig. 1(c)), the physical MPPT is not required because the inverter itself regulates the dc-link voltage

corresponding to V_{mpp} which is generated by perturb and observe (P&O) algorithm. Of the several algorithms of MPPT, P&O algorithm is most popular and extensively used, which is shown in Fig. 2 [10]. The following equation is used to identify V_{mpp} [10].

$$V_{mpp}(k) = V_{mpp}(k-1) + M \times \text{sign}(dp/dv) \quad (1)$$

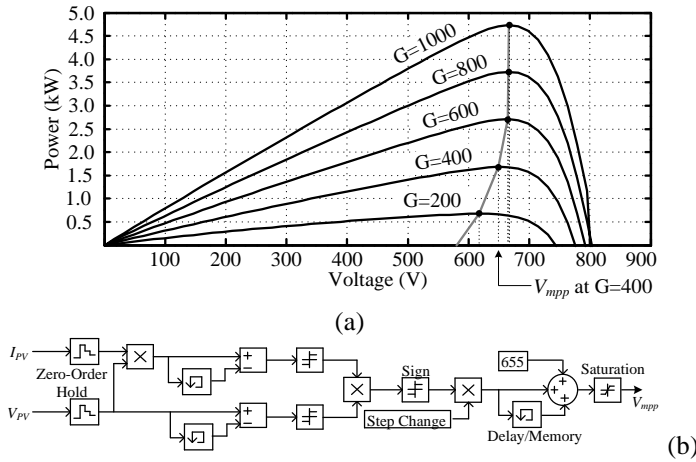

Fig. 2: (a) P-V curve, (b) P&O algorithm

3. REGULATION OF VOLTAGE AT AC BUS

In [11, 12], a scalar control based IM motor is proposed to drive the water pump. However, due to limitations in voltage/frequency ratio, this scheme is not efficient method for PV based water pumping system even it is relatively simple to implement. Further, this requires instantaneous control of the torque hence required maintenance. On the other hand, a vector control is facilitate with de-couples the vectors of field current and armature flux so that they may be controlled independently to provide fast transient response [13] and the generated torque is expressed by [14]

$$T_e = KI_d I_q \quad (2)$$

The control of battery connected system (Fig. 1(a)) can be implemented with the help of Fig. 3(a) and (b). The voltage at dc-link can be regulated with the help of switch Q_1 and Q_2 (Fig. 3(a)) and the inverter is controlled by using vector control (Fig. 3(b)). Therefore, battery can charge and discharge based on power difference between PV and load to maintain balanced power.

Generally the torque on the motor depends on water head in a water pumping system. As load torque becomes constant, the load power depends only on speed of the motor. So the power mismatch between load and generated power will reflect the change in speed. In the similar manner, when PV power is more/less than load requirement, dc-link voltage (V_{dc}) will increase/decrease. In order to regulate AC bus voltage (i.e, output of inverter where motor loads are connected), V_{dc} needs to be kept constant at its reference value (V_{mpp}). Hence, in the proposed control strategy, in order to keep dc-link voltage constant, the speed of IM is allowed to vary within permissible limits. The proposed control schemes without battery are presented in Fig. 3(b) and (c). Control scheme shown in Fig. 3(b) corresponds to power based control {Fig. 1(b)} while control scheme shown in Fig. 3(c) corresponds to voltage based control {Fig. 1(c)}. Since in Fig. 1(b) and (c), there is no energy storage device, power matching between generation and load demand is achieved on the cost of change in frequency of inverter by keeping the output voltage constant.

Since, frequency of inverter is changing, speed of motor will also change. Hence for safe and reliable operation of motor, controller allows IM to run within permissible minimum and maximum speeds. Assuming head 25m and the maximum water discharge (Q) as 300 gal/min.,

In voltage based control, the reference frequency (F^*) is generated by proportional plus integral (PI-2) from difference between V_{dc} and $(V_{mpp} + V_{dcm})$. The multiplication of F^* with $120/P$ (P is number of poles of IM) gives the reference speed (ω^*). In order to limit the speed between minimum and maximum value, a limiter is connected after ω^* generated by PI-2 controller as shown in Fig. 3(c). The permissible speed (limited by limiter) is the input signal to vector control and vector control generates the required pulses (S_1-S_6) for inverter. F_{max} is the maximum allowable frequency corresponding to maximum speed. Under the scenario of PV power becomes more than induction motor power, then speed of induction motor and dc-link voltage both may rise beyond permissible limit. Hence to avoid this resistive type of dump load is connected so that it can consume surplus power from PV. Considering the protection of dc bus, the rise in dc-link voltage is allowable up to 5% of V_{mpp} and it is denoted by V_{dcm} . If generated power by PV is more than the IM load power, the controller can allow the speed of IM up to maximum limit (i.e, F_{max}). When $F^* \geq F_{max}$, V_{dcm} is added to V_{mpp} , which is now reference signal of dc-link voltage. The error signal ($V_{mpp} + V_{dcm} - V_{dc}$) is given to PI controller (PI-1) and output of PI-1 is responsible for generating PWM pulse to switch S_d which in turn controls the surplus power dissipated to dump load (R_d). Then the dc-link voltage can regulate by both the inverter and the dump load switch (S_d), so the dc-link voltage may rise up to permissible value ($V_{mpp} + V_{dcm}$). An energy management algorithm is required to maintain power balance among PV, load and dump load. A proper energy management helps in reducing power wasted in dump load under the scenario of PV power more than any of the induction motors power.

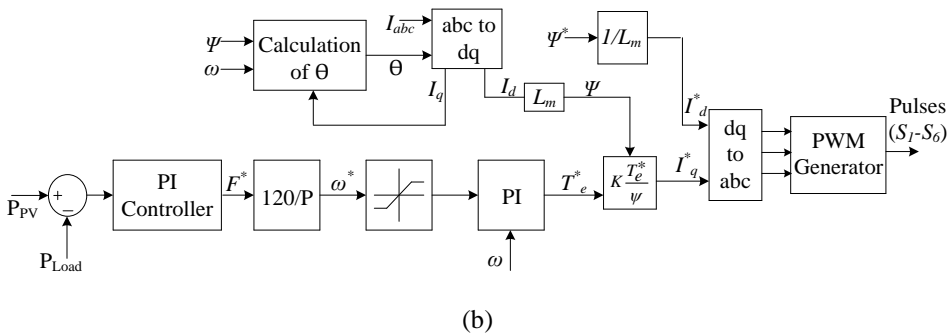
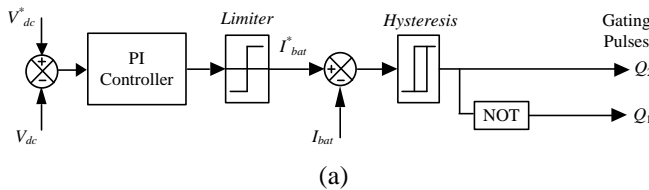

The real time digital simulator (RTDS) is used to perform real time operations under a digital simulator platform [16, 18]. The RTDS is a combination of advanced computer hardware and comprehensive software. It has a parallel-processing hardware architecture assembled in modular unit. Every block contains their own processing and communication modules with interconnection to other blocks.

In order to implement HIL configuration, scholars have used DSP/microcontrollers and RTDS modules [20]. The detailed plant model is implemented on RTDS which can closely replicate the dynamics of physical system and control can be implemented on DSP/microcontroller. In this thesis in order to setup the HIL, two RTDS units (manufactured by OPAL-RT Technologies) are used with corresponding computers. One unit is used for modeling of plant and other is used for control as shown in Fig. 5. Both the units are facilitated with analog and digital cards. The signals of two units are communicated with each other with interfacing cable as shown in rear side of OPAL-RT in Fig. 5. The analog signals are going from plant to control and digital signal are coming from control to plant as shown in Fig. 6.

Consider that two IM (i.e., 3.0 and 4.0 hp) are connected to the system. Assumed that 3.0 hp motor is running and irradiance increases from 800 to 1000 W/m². Due to increase in irradiance power generated from PV increases. Hence, speed of motor increases up to its permissible limit (i.e., 188.5 rps) as shown in Fig. 7. However, still power generated by PV is more than that of load; therefore controller increases dc-link voltage. Because of increase in dc-link voltage the power output from PV reduces and hence, speed of motor settles at 188.5 rad/s (Fig. 7).

Now consider that both the motors are running and irradiance is 1000 W/m². Assume that 3.0 hp motor is disconnected suddenly hence speed of 4.0 hp motor increased as shown in Fig. 8 (yellow color). Motor speed is still under limit; therefore, dc-link voltage is operated at V_{mpp} (voltage at maximum power). Corresponding dc voltage is shown in Fig. 8 (pink color).

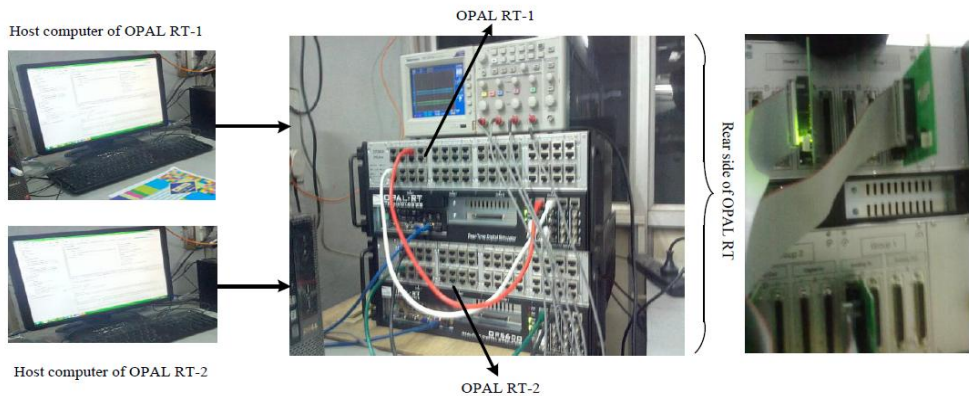
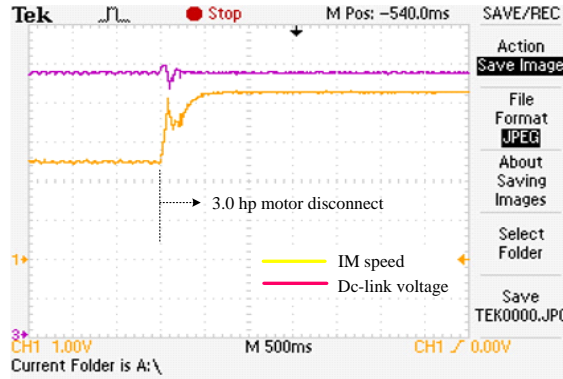

Fig. 5: HIL laboratory setup with OPAL-RT units



(CH-1, 1V= 40rad/s, CH-3, 1V=100volts)

Fig. 8: Dc-link voltage and speed when 3.0 hp motor is suddenly disconnected.

5. CONCLUSIONS

In this chapter, control of PV based water pumping system consists of induction motors (IM) without battery storage is presented. Hence, proposed system provides cost effective solution as compared to system with energy storage. Using novel inverter control, the power balance between PV generation and load is achieved by maintaining dc-link voltage constant at its reference value (V_{dc}^*) and controlling the speed of induction motor within permissible limits. Due to proposed voltage based inverter control, an extra dc-dc converter for MPPT is not required and inverter itself acts as MPPT circuit. The proposed integrated controller requires only measurements of dc-link voltage and load currents, no need to measure the PV and load powers. Different cases are discussed based upon change in solar irradiance and motor load. Through the simulation and HIL results it is concluded that performance of the controllers is satisfactory under conditions of change in irradiance and load.

References

- [1]. V. Gali and P. B. Amrutha, "Fast dynamic response of SEPIC converter based photovoltaic DC motor drive for water pumping system," International Conference on Circuit, Power and Computing Technologies, 2016, pp. 1-5, doi: 10.1109/ICCPCT.2016.7530298.
- [2]. M. A. Elgendy, B. Zahawi, and D. J. Atkinson, "Comparison of Directly Connected and Constant Voltage Controlled Photovoltaic Pumping Systems", *IEEE Transactions on Sustainable Energy*, Vol. 1, No. 3, Oct. 2010.
- [3]. A. Betka and A. Moussi, "Performance Optimization of a Photovoltaic Induction Motor Pumping System", *Renewable Energy*, No. 29, pp. 2167- 2181, 2004.
- [4]. K. V. Mahesh, S. Angadi and A. B. Raju, "Single Stage PV Water Pumping System With MPPT Employing Three Phase Induction Motor," 2018 International Conference on Current Trends towards Converging Technologies (ICCTCT), 2018, pp. 1-5, doi: 10.1109/ICCTCT.2018.8550899.
- [5]. T. Eswam and P. L. Chapman, "Comparison of Photovoltaic Array Maximum Power Point Tracking Techniques", *IEEE Transactions on Energy Conversion*, Vol. 22, No. 2, pp. 439-449, June 2007.
- [6]. D. Sera, R. Teodorescu, J. Hantschel and M. Knoll, "Optimized Maximum Power Point Tracker for Fast-Changing Environmental Conditions", *IEEE Transactions on Industrial Electronics*, Vol. 55, No. 7, pp. 2629-2631, July 2008.

- [7]. Handbook of Secondary Storage Batteries and Charge Regulators in Photovoltaic Systems Final Report, *prepared by Exide Management and Technology Company*, West College Avenue, Yardley, Pennsylvania, Aug. 1981.
- [8]. S. Xu, R. Shao, B. Cao and L. Chang, "Single-phase grid-connected PV system with golden section search-based MPPT algorithm," in Chinese Journal of Electrical Engineering, vol. 7, no. 4, pp. 25-36, Dec. 2021, doi: 10.23919/CJEE.2021.000035.
- [9]. S. Najafi-Shad and S. M. Barakati, "Intelligent MPPT and DC-Link Voltage Control in the Hybrid PV-DFIG system," 2020 28th Iranian Conference on Electrical Engineering (ICEE), 2020, pp. 1-5, doi: 10.1109/ICEE50131.2020.9260720.
- [10]. S. Singh, S. Manna, M. I. Hasan M and A. K. Akella, "Implementation of Perturb & Observe MPPT Technique using Boost converter in PV System," 2020 International Conference on Computational Intelligence for Smart Power System and Sustainable Energy (CISPSSE), doi: 10.1109/CISPSSE49931.2020.9212203.
- [11]. N. Hamrouni, M. Jraidi and A. Che'rif, "Theoretical and Experimental Analysis of the Behaviour of a Photovoltaic Pumping System", *Solar Energy* Vol. 83, pp.1335–1344, 2009.
- [12]. N. Yussif, A. S. Abdel-Khalik and A. M. Mohamed, "An Improved Quadratic V/f-Based Control of Photovoltaic Battery-Less Induction Motor Driven Water Pumping System," 2019 International Conference on Sustainable Energy Engineering and Application (ICSEEA), 2019, pp.1-6, doi: 10.1109/ICSEEA47812.2019.8938614.
- [13]. B. Kimiaghalam, M. Rahmani and H. Halleh, "Speed & torque vector control of induction motors with Fuzzy Logic Controller," 2008 International Conference on Control, Automation and Systems, 2008, pp. 360-365, doi: 10.1109/ICCAS.2008.4694671.
- [14]. R. Gunabalan, P. Sanjeevikumar, F. Blaabjerg, O. Ojo and V. Subbiah, "Analysis and Implementation of Parallel Connected Two-Induction Motor Single-Inverter Drive by Direct Vector Control for Industrial Application," in IEEE Transactions on Power Electronics, vol. 30, no. 12, pp. 6472-6475, Dec. 2015, doi: 10.1109/TPEL.2015.2429591.
- [15]. <http://www.fao.org/docrep/W7314E/w7314e0r.htm>.
- [16]. C. Pradhan, M. K. Senapati, S. G. Malla, P. K. Nayak and T. Gjengedal, "Coordinated Power Management and Control of Standalone PV-Hybrid System With Modified IWO-Based MPPT," in IEEE Systems Journal, vol. 15, no. 3, pp. 3585-3596, Sept. 2021, doi: 10.1109/JSYST.2020.3020275.
- [17]. P. Jayakumar, "Solar Energy Resource Assessment Handbook", prepared for Asian and Pacific Centre for Transfer of Technology of the United Nations – Economic and Social Commission for Asia and the Pacific (ESCAP), Sept. 2009
- [18]. W. Qiao, G. K. Venayagamoorthy and R. G. Harley, "Real-Time Implementation of a STATCOM on a Wind Farm Equipped With Doubly Fed Induction Generators", *IEEE Transactions on Industry Applications*, Vol. 45, No. 1, pp. 98-107, Jan/Feb. 2009.