

Shunt Active Power Filter with Three Level Inverter using Hysteresis Current Controllers

Ramakrishna Raghutu, Vasupalli Manoj and Narendra Kumar Yegireddy

Dr. Ramakrishna Raghutu, Assistant Professor, Department of Electrical and Electronics Engineering, GMR Institute of Technology, Rajam, Vizianagaram, Andhra Pradesh, India – 532127.

Dr. Vasupalli Manoj, Assistant Professor, Department of Electrical and Electronics Engineering, GMR Institute of Technology, Rajam, Vizianagaram, Andhra Pradesh, India – 532127.

Dr. Narendra Kumar Yegireddy, Professor, Department of EEE, Satya Institute of Technology and Management, Vizianagaram, Andhra Pradesh, India – 535003.

Abstract: This document introduces a Shunt Active Power Filter (SAPF) for three-phase three-wire systems, utilizing a Cascaded H Bridge Multilevel Inverter. The Hysteresis Current Control technique provides numerous benefits, including simplicity, minimal current tracking error, and immunity to load parameter variations. The research presented in this paper focuses on a three-level hysteresis band current controller for a three-level Cascaded H Bridge Inverter, specifically applied to SAPF. The proposed scheme effectively utilizes the available voltage states of the three-level inverter to confine the current error within predefined limits. The performance of this method is validated using Powersim (PSIM) software, which demonstrates the effective compensation capability of SAPF with three-level hysteresis band current controllers.

Keywords: Shunt Active Power Filter, Cascaded H Bridge Inverter, Three Level Hysteresis Modulator.

Corresponding Author: ramakrishna.r@gmrit.edu.in

1. Introduction

The demand of high efficiency, low cost power converter in most of the power supply application using single phase or three phase grid supply as the source has increased over the years. The use of such power converter is to control instant of conduction of voltage or current over the time period results in generation of harmonics. As a result, voltage and/or current harmonics are injected by the load end into the distribution system causing distortion of supply voltage. A more conventional approach to solve the problem is to use combination of tuned passive filters. These filters have several disadvantages such as de-tuning of filters over the period, bulky and large in size, parallel resonance and high cost. Shunt Active Power Filter (SAPF) is considered as promising solution for mitigation of current harmonics at the point of common coupling[1-7] . SAPFs are mostly comprised with voltage source inverter (VSI) instead of a current source inverter (CSI), because VSI has a certain advantage over CSI, like light in weight, cheaper and easy to expand as a multilevel version.

Conventionally, a two level VSI is used for SAPF application where each phase consists of two switches operated in complementary manner and is controller independently. For medium voltage applications, either two level VSI are connected through transformer such that voltage across the phases of inverter are reduced or no. of switches are connected in series to increase the voltage capabilities of overall system. In either case, overall efficiency of the system is compromised and at the same time high dv/dt imposes additional stress on switches. Multilevel Inverters(MLIs) have proven themselves as better alternative for medium voltage SAPF application[8-10]. While the need of separate DC link source limits the application of Cascaded H Bridge MLI in other applications, it is termed as an important advantage for Renewable Energy Sources as well as Shunt Active Power Filter applications. Unlike other MLI configurations where control of higher level inverter poses serious challenge, CHB can be easily extended to higher level inverter without involving complicated control.

The performance of the shunt active power filters largely depends upon power processing circuit, control algorithm as well as switching strategy used to control the inverter. The switching strategy involves minor current loops because of nature of current of SAPF. Various current control methods used for the SAPF are available in the literatures[11-17]. Various current control techniques such as Stationary PI, Current Controller with Proportional Resonant Controller, State Feedback controller are classified as Linear Current Control. On the other hand, Hysteresis Current Control and delta modulation are classified as Non-linear current control. A constant frequency current control method produces a required amount of reference voltages. These voltages are synthesized using a linear modulator operating at fixed frequency. Nonlinear current control selects switching signal of inverter based on comparison of error of inverter output current and commanded current with pre-defined band limits on instantaneous basis. If the error of current violates pre-defined positive limit or negative limit of the hysteresis band, upper switch is turned OFF or turned ON respectively. The current error range directly controls the switches of the voltage source inverter. Both the current control methods have their own advantages and disadvantages. However, hysteresis current control technique is independent of design parameters as well as immune to variation of device parameters. It also offers advantages like simple to implement, automatic peak current control and unconditional stability[18-20].

In this paper, three level CHB inverter based SAPF using three level hysteresis band current controller is simulated for compensation of current harmonics produced by the

nonlinear load in the distribution system. The load current harmonics and/or reactive power of the load is effectively compensated with the SAPF presented in the paper. The paper is organized as follows: The three level hysteresis band current control is explained in section-II. Section-III discusses application and implementation of this method for SAPF application. The performance of method is presented in section-IV using PSIM software tool.

2. Three Level Hysteresis Band Current Control

The switching signals of CHB inverter applied for SAPF applications are derived from three level hysteresis band current control. Such a three level control is independently developed for each phase of the Inverter. For sake of understanding, three level hysteresis band current control for one phase is described here in brief.

A Three-level hysteresis band current control method is used to control currents of three level inverter based shunt active power filter. In conventional hysteresis current control method, single band is used whereas in three level hysteresis modulation two bands are used: one is upper band and second is lower band. A small offset between two bands is provided such that three level outputs are generated satisfactorily. The current error is obtained by comparing reference and actual current as shown in Fig. 1. Whenever current error signal crosses the outer most hysteresis band, the output of inverter either positive voltage level or negative voltage level to force the current error in opposite direction.

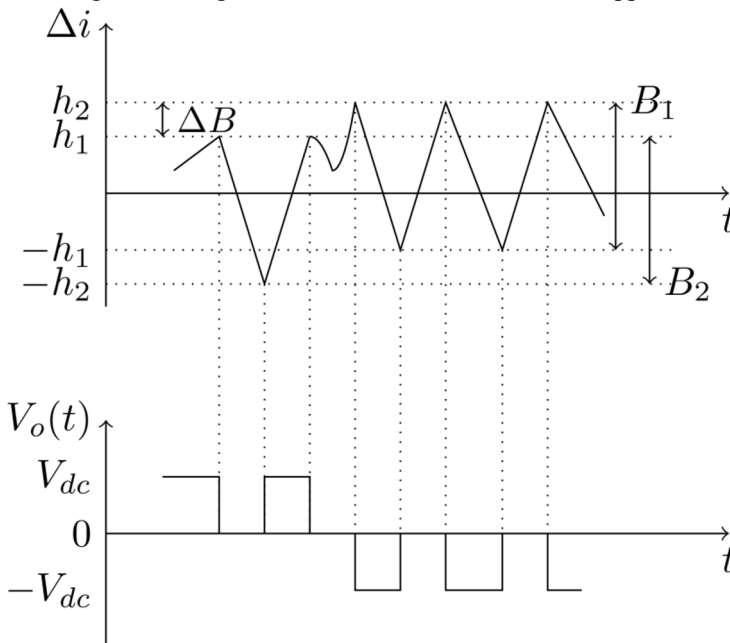

Figure 1 Three Level Hysteresis Band Current Controller.

Whenever the current error touches inner boundary of hysteresis band of B_1 and B_2 , zero switching state is selected and forces current error to change its direction. In certain conditions, the application of zero switching state is not sufficient to reverse the direction of current error. This will lead current error to cross the outer boundary (B_1 or B_2). When the current error touches outer boundary of B_1 , negative switching state is generated

resulting in output voltage of $-V_{dc}$. Similarly, outer boundary of B_2 generates positive switching state and the output voltage is $+V_{dc}$. Both conditions force reversal of current error and thus ensure current error trajectory to remain within specified limits[21-23].

3. Implementation of Three Level Hysteresis Band Current Controller

Figure 2 illustrates a Cascaded H-Bridge Inverter with three levels, which is proposed as a solution for reducing current harmonics caused by nonlinear loads in a three-phase three-wire system. While this study focuses on implementing a SAPF using a three-level CHB inverter, it can be readily expanded to higher levels of inverters[24]. However, it should be noted that increasing the number of levels in the inverter leads to more complex control and may introduce voltage imbalance issues[16].

The inverter output is given by,

$$v_c(t) = u(t) V_{dc} \tag{1}$$

The switching states according to output voltage of three level inverter are given in Table 1.

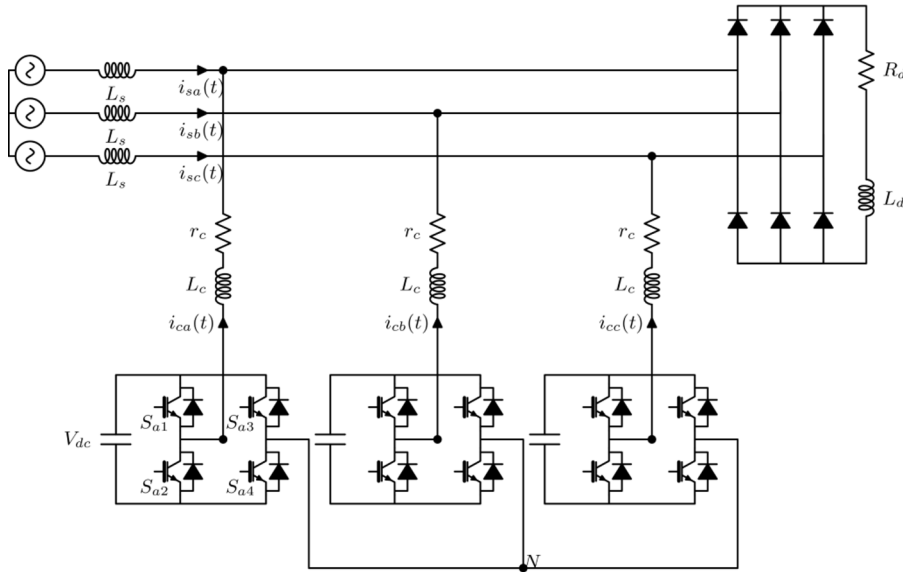

Fig. 2 SAPF with three level inverter.

Table 1 Switching states and output voltage for CHB three level inverter

Output Voltage V_{out}	S_{a1}	S_{a2}	S_{a3}	S_{a4}
$+V_{dc}$	1	0	0	1
0	1	0	1	0
0	0	1	0	1
$-V_{dc}$	0	1	1	0

4. Simulation Results

An assessment was conducted on a 1.5kVA Cascaded Three Level Inverter with a Three Level Hysteresis Band Current Controller using a PSIM simulator. The reference current

was produced through p-q theory, and the three level hysteresis band current controllers were utilized to control the switching operation of the cascaded H bridge inverter. The system is simulated with parameters mentioned in Table 2.

Table 2 Simulations Parameters

Parameters	Numerical Value
Supply Voltage	380 V Line to Line
Supply Frequency	50 Hz
Load Resistance (DC side)	60 Ω
Load Inductance (DC side)	100 mH
Coupling inductor	10 mH
DC link Capacitor C_{dc}	3300 μ F
Reference DC Voltage V_{dc}	350 V
Hysteresis Band	$B_1 = -0.30 - +0.30$ $B_2 = -0.37 - +0.23$

Load Current, Compensating Current injected by SAPF and Source Current waveforms after compensation are shown in Fig. 3 (a), (c) and (e) respectively. Due to non-linear load, the load current waveform becomes non-sinusoidal which contains lower order harmonics out of which 5th and 7th harmonics are dominant. Corresponding to each waveform, the FFT spectrum is shown in adjacent diagram i.e. Fig. (b), (d) and (f). It is evident that harmonics of load current are mitigated by compensating current injected by the SAPF and as a consequence the current harmonics in the load are eliminated making the source current nearly sinusoidal.

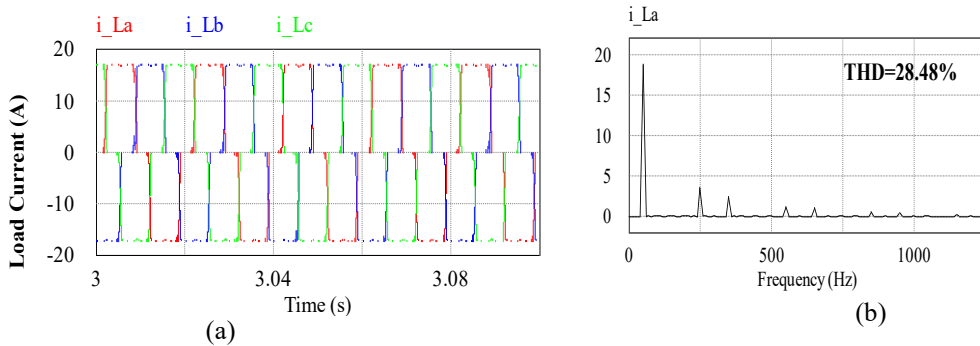

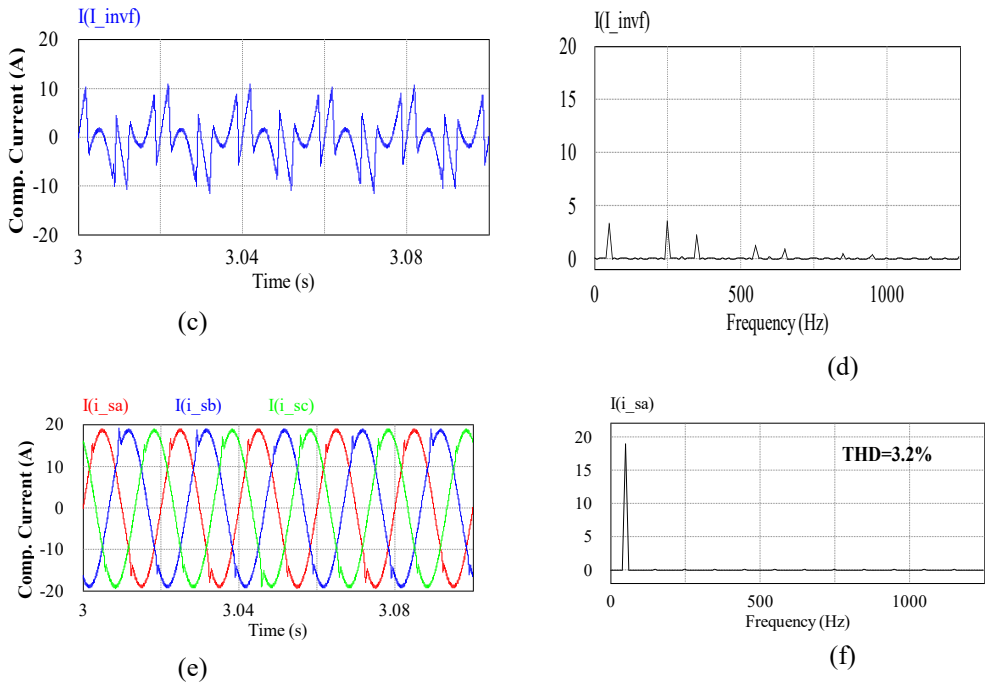

Fig. 3 (a) Three Phase Load Current i_{La} , i_{Lb} , i_{Lc} (b) FFT Spectrum of Load Current i_{La} (c) Phase-A Compensating Current i_{ca} (d) FFT Spectrum of Compensating Current i_{ca} (e) Three Phase Source Currents i_{sa} , i_{sb} , i_{sc} (f) FFT Spectrum of source current i_{sa} .

The Load current exhibits a Total Harmonic Distortion (THD) of 28.48%, while the Source Current THD, after implementing the suggested three level hysteresis band current controller for compensation, is 3.2%. This value falls comfortably within the acceptable limits. To assess the system's dynamic performance, a step change in load is introduced at $t = 2.5s$. As shown in Fig. 4, the inverter draws additional current during dynamic condition. This current is the result of DC link voltage error being processed by Voltage Controller. In this case, three independent DC link voltage controllers are used for each CHB module due to which there is slight unbalance during transient stage which is evident from Fig. 5. However, reference values are quickly established owing to action of the controller and net exchange of active power becomes zero.

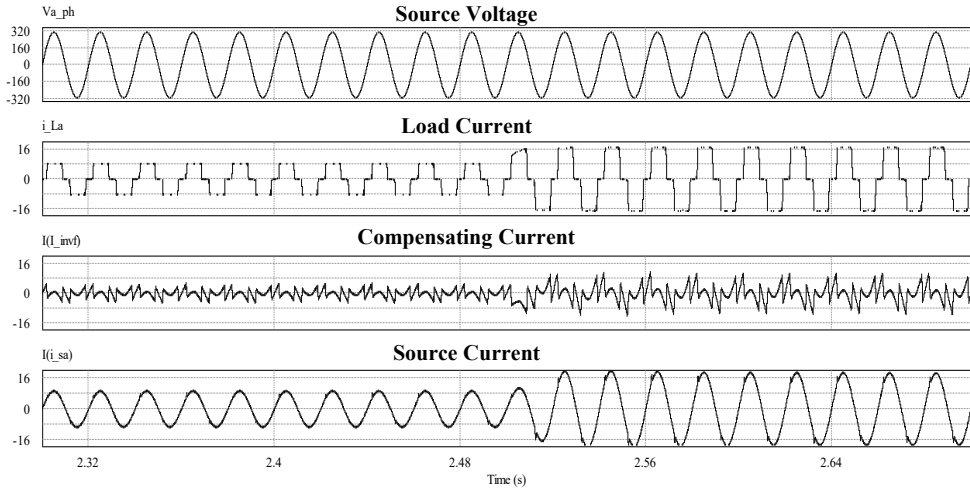

Fig. 4 Dynamic response of CHB- MLI based SAPF for step change in Load: Source Voltage v_{an} (volts), Load Current i_{La} (A), Compensating Current i_{Ca} (A) Source Current i_{sa} (A).

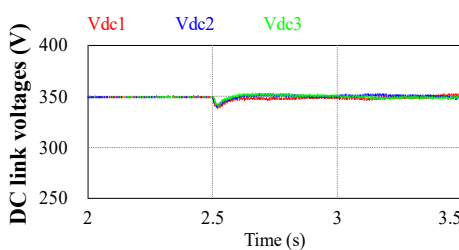

Fig. 5 Response of DC link Voltage for step change in Load.

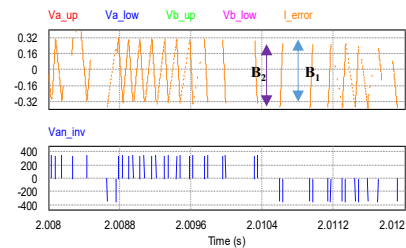

Fig. 6 Current error Δi_{ca} along with hysteresis bands and Output Switching State selection V_{out} for one phase.

The performance of three level hysteresis current controller can be evaluated from Fig. . The waveforms shown are for end of positive half cycle and beginning of negative half cycle of Phase-A. This is done in order to illustrate the switching action of developed current controller. The hysteresis bands of B_1 and B_2 are selected as per Table 2. In comparison to Multi-band hysteresis current controller, where inner band and outer band have different width for the control; the three level current controller developed in this paper has *equal* and *wider* width of bands which results in reduction in switching frequency. As long as current error remains within the limit, switching states swing between zero switching state and positive switching state (or negative switching state) depending upon the current error position in hysteresis band. Since reference current synthesized by SAPF inverter has multiple zero crossings as well as high current rise during the commutation of non-linear load devices, the current error often violates band limits and hence the next switching state should act in order to force the current error back to the defined limits. As a result, switching state of opposite nature should be selected instead of zero vector. This is ensured with the help of finite state machines and appropriate

logic. Fig. 7 shows output voltage of one phase of inverter as well as line to line voltage for SAPF.

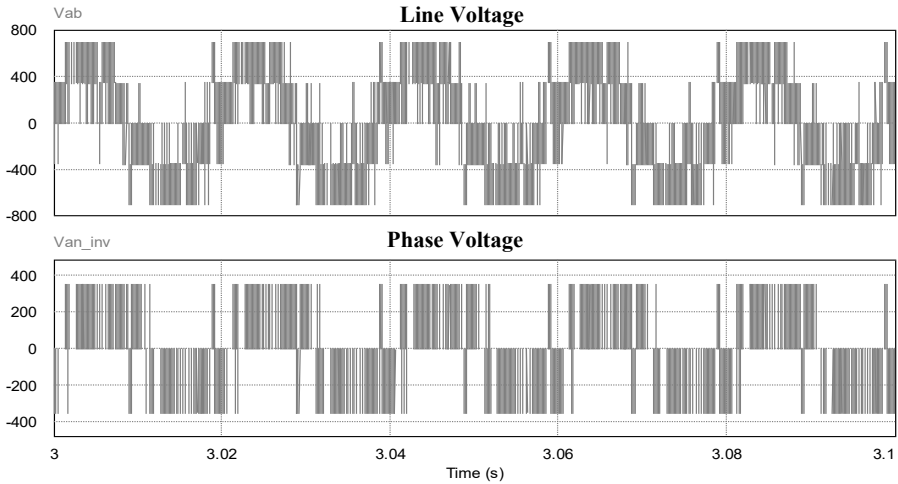

Fig. 7 Inverter Output Voltage for one phase of SAPF (V_{an}) and Line Voltage of SAPF (V_{ab}).

5. Conclusion

This paper presents a simulation of a three-level hysteresis band current controller for a three-level Cascaded H-Bridge Multilevel Inverter used in a Shunt Active Power Filter (SAPF) application. The method selects best possible voltage vector for each phase of Cascaded H Bridge inverter and allows larger band limits to be realized while maintaining smooth transition from one state to another state which serves as an advantage for HCC technique. The SAPF effectively compensates for harmonics in the system whereas current ripples are reduced in the output current.

6. References

- [1] W.M. Grady, M.J. Samotyj, A.H. Noyola, Survey of active power line conditioning methodologies, *IEEE Transactions on Power Delivery*, 5 (1990) 1536-1542.
- [2] H. Akagi, New trends in active filters for power conditioning, *IEEE Transactions on Industry Applications*, 32 (1996) 1312-1322.
- [3] A. Ghosh, G. Ledwich, *Power Quality Enhancement using Custom Power Devices*, Kluwer Academic Publisher, 2002.
- [4] A. Ghosh, G. Ledwich, Load compensating DSTATCOM in weak AC systems, *IEEE Transactions on Power Delivery*, 18 (2003) 1302-1309.
- [5] J. Allmeling, A control structure for fast harmonics compensation in active filters, *IEEE Transactions on Power Electronics*, 19 (2004) 508-514.
- [6] B. Singh, K. Al-Haddad, A. Chandra, A review of active filters for power quality improvement, *IEEE Transactions on Industrial Electronics*, 46 (1999) 960-971.
- [7] E. Sundaram, M. Venugopal, On design and implementation of three phase three level shunt active power filter for harmonic reduction using synchronous reference frame theory, *International Journal of Electrical Power & Energy Systems*, 81 (2016) 40-

47.

- [8] J.-S. Lai, F.Z. Peng, Multilevel converters-a new breed of power converters, *IEEE Transactions on Industry Applications*, 32 (1996) 509-517.
- [9] J. Rodriguez, J.-S. Lai, F.Z. Peng, Multilevel inverters: a survey of topologies, controls, and applications, *IEEE Transactions on Industrial Electronics*, 49 (2002) 724-738.
- [10] H. Abu-Rub, J. Holtz, J. Rodriguez, G. Baoming, Medium-Voltage Multilevel Converters; State of the Art, Challenges, and Requirements in Industrial Applications, *IEEE Transactions on Industrial Electronics*, 57 (2010) 2581-2596.
- [11] D.M. Brod, D.W. Novotny, Current Control of VSI-PWM Inverters, *IEEE Transactions on Industry Applications*, IA-21 (1985) 562-570.
- [12] M. Marchesoni, High-performance current control techniques for application to multilevel high-power voltage source inverters, *IEEE Transactions on Power Electronics*, 7 (1992) 189-204.
- [13] T.A. Trivedi, R. Jadeja, P. Bhatt, A Review on Direct Power Control for Applications to Grid Connected PWM Converters, *Engineering, Technology & Applied Science Research*, 5 (2015) pp-841.
- [14] S.P. Gawande, M.R. Ramteke, Current controlled PWM for multilevel voltage-source inverters with variable and constant switching frequency regulation techniques: A review, *Journal of Power Electronics*, 14 (2014) 302-314.
- [15] S. Gautam, R. Gupta, Switching Frequency Derivation for the Cascaded Multilevel Inverter Operating in Current Control Mode Using Multiband Hysteresis Modulation, *IEEE Transactions on Power Electronics*, 29 (2014) 1480-1489.
- [16] S.S. Patnaik, A.K. Panda, Cascaded three-level inverter based shunt active filter for power conditioning application, in: 2013 Annual IEEE India Conference (INDICON), pp. 1-5.
- [17] S. Gautam, R. Gupta, Three-level inverter based shunt active power filter using generalized hysteresis current control method, in: *Power, Control and Embedded Systems (ICPES)*, 2010 International Conference on, pp. 1-6.
- [18] M.P. Kazmierkowski, L. Malesani, Current control techniques for three-phase voltage-source PWM converters: a survey, *IEEE Transactions on Industrial Electronics*, 45 (1998) 691-703.
- [19] S. Buso, L. Malesani, P. Mattavelli, Comparison of current control techniques for active filter applications, *IEEE Transactions on Industrial Electronics*, 45 (1998) 722-729.
- [20] M.I.M. Montero, E.R. Cadaval, F.B. Gonzalez, Comparison of Control Strategies for Shunt Active Power Filters in Three-Phase Four-Wire Systems, *IEEE Transactions on Power Electronics*, 22 (2007) 229-236.
- [21] A. Shukla, A. Ghosh, A. Joshi, Hysteresis Modulation of Multilevel Inverters, *IEEE Transactions on Power Electronics*, 26 (2011) 1396-1409.
- [22] G.H. Bode, D.G. Holmes, Implementation of three level hysteresis current control for a single phase voltage source inverter, in: *Power Electronics Specialists Conference, 2000. PESC 00. 2000 IEEE 31st Annual*, pp. 33-38 vol.31-38 vol.31.
- [23] H. Komurcugil, Double-band hysteresis current-controlled single-phase shunt active filter for switching frequency mitigation, *International Journal of Electrical Power & Energy Systems*, 69 (2015) 131-140.
- [24] N.A. Al-Emadi, C. Buccella, C. Cecati, H.A. Khalid, A novel DSTATCOM\ with 5-level CHB\ architecture and selective harmonic mitigation algorithm, *Electric Power Systems Research*, 130 (2016) 251-258.