

# Simulation of SIMO based DC-DC Converter for Multi Level Solar PV Inverter

Ajay Agrawal, Pavan Chaudhary, Ravindra Kumar and Kuldeep Singh Kulhar

Mr. Ajay Agrawal, Assistant Professor, Department of Mechanical Engineering, Sanskriti University, Mathura, Uttar Pradesh, India, Email Id- [ajayagrawal.me@sanskriti.edu.in](mailto:ajayagrawal.me@sanskriti.edu.in)

Pavan Chaudhary, Assistant Professor, Maharishi School of Engineering & Technology, Maharishi University of Information Technology, Uttar Pradesh, India, Email Id- [chaudharycarac6@gmail.com](mailto:chaudharycarac6@gmail.com)

Ravindra Kumar, Assistant Professor, Civil Engineering, Vivekananda Global University, Jaipur, India, Email Id-[kumar.ravindra@vgu.ac.in](mailto:kumar.ravindra@vgu.ac.in)

Kuldeep Singh Kulhar, Professor, Civil Engineering, Vivekananda Global University, Jaipur, India, Email Id-[k.singh@vgu.ac.in](mailto:k.singh@vgu.ac.in)

**Abstract:** Simulation of SIMO based DC-DC Converter for multi level Solar PV Inverter is presented in this paper. In order to reduce the number of distinct DC supplies for an H-bridge inverter SIMO DC-DC converter is applied which in turn allows the usage of single PV system for a multi level H-bridge inverter. Simulation model of three level and five level inverters is built and results are presented to validate the proposed ideas.

**Keywords:** DC supplies;cuk;H-bridge;PV inverter

## 1. Introduction

In recent trends, there is an increasing demand for generation of electricity from renewable resources. Among all of them solar has gained a lot of popularity due to its abundant availability, eco-friendliness and little maintenance. The demand for solar energy has increased by 20-25% in the past 20 years which is very considerable [1]. Usage of PV systems for power generation is being more productive.

The existing PV inverters are all H-bridge inverters. This is because of the reduced number of components i.e., no flying capacitors and diodes, simple structure and functioning, modularity [2]-[3]. But the major drawback here is that it requires distinct dc supplies. When it comes to the case of PV inverter each H-Bridge would require a distinct

\* Corresponding author: [ajayagrawal.me@sanskriti.edu.in](mailto:ajayagrawal.me@sanskriti.edu.in)

PV [4] i.e., no. of panels is  $(n-1)/2$  where  $n$  represents no. of levels of the inverter. This maximizes the cost where the growing demand is difficult to be met at a reasonable cost.

This paper emphasizes on the development of single input multi output(SIMO) dc power supply for the solar PV inverter wherein a single PV yields six output voltages either different or the same which can be varied as per the requirement [5] which therefore becomes an input to the inverter. This can be extended up to seven levels. The system is configured by a PV, a combination of Cuk-SEPIC-boost, buck boost converters and a H-Bridge inverter. The DC-DC converters possess simple layout and operation with high efficiency [6]. In this paper, the entire set up is demonstrated along with mathematical analysis and simulation results are presented.

## 2. System Configuration

### 2.1. Cuk Converter

It is a DC-DC converter as shown in Fig.1 which increases or decreases the voltage. It is the combination of buck and boost converters which gives an output opposite polarity to that of the input [7]. The base converter here is going to be the Cuk converter.

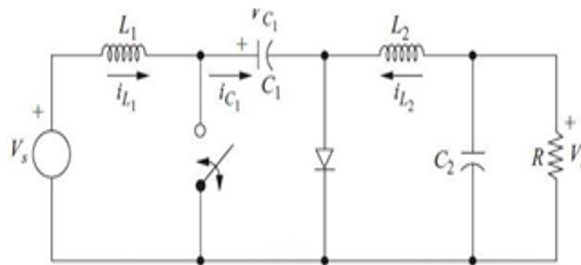

Fig. 1 Cuk Converter

### 2.2. Cuk Converter analysis

The converter consists of two inductors  $L_1$  and  $L_2$ , two capacitors  $C_1$  and  $C_2$ . When the switch is ON the diode is reverse biased and the output is supplied by the  $C_1$ ,  $L_1$ ,  $R$  as shown in Fig.2.

Fig.3 shows when the switch is OFF the diode is forward biased and the output is supplied by the freewheeling action of diode. The inductor on the input side acts as a filter for the dc supply to prevent large harmonic content.

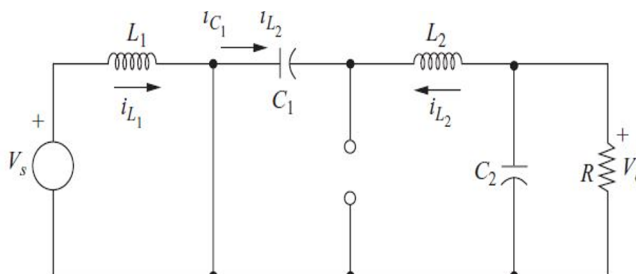

Fig.2 Cuk converter- when switch is ON.

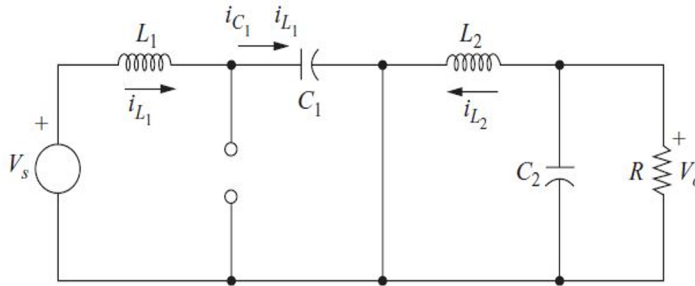

Fig.3 Cuk converter- when switch is OFF.

The output voltage is given by

$$V_0 = \frac{-D V_g}{1-D} \tag{1}$$

The values of inductors and capacitors are given by

$$L_1 = \frac{V_g D}{f \Delta i_{L1}} \tag{2}$$

$$C_1 = \frac{V_0 D}{\Delta V_{c1} R f} \tag{3}$$

$$L_2 = \frac{V_g D}{f \Delta i_{L2}} \tag{4}$$

$$C_2 = \frac{\Delta i_{L2}}{8 f \Delta V_2} \tag{5}$$

The values are calculated as \$L\_1=L\_2=456\mu\text{H}\$ and \$C\_1=16.5\mu\text{f}\$, \$C\_2=15\mu\text{f}\$ by taking input voltage as 48V, current ripple is 20 to 30% of load current, voltage ripple is 3% of load voltage.

### 2.3. Controller

The controller part constitutes the pulse generation circuit. Pulses are generated by pulse width modulation technique. The input voltage is compared with a reference to generate the pulses by PWM technique.

### 2.4. Cuk Converter based SIMO converter

Now this Cuk converter is combined with a SEPIC, boost and a buck boost converter as shown in Fig.4 which would help in giving six outputs [7] whose voltage levels may vary based on the loads connected. Converters required their ratings in order to exhibit their superior response [8-9].

The opposite polarities are obtained by connecting different converters in a cascaded manner. This more specifically serves the purpose of a DC supply to a H-bridge.

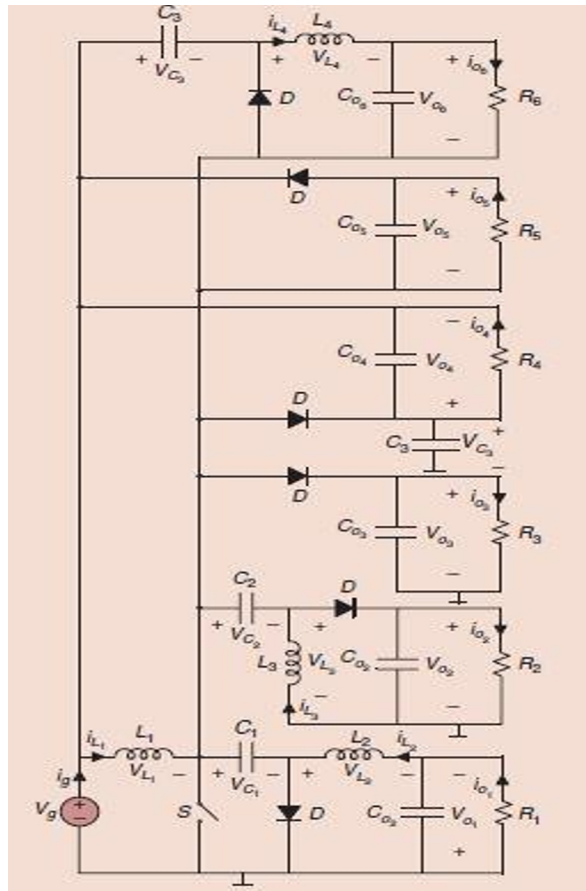

Fig.4 SIMO DC-DC converter.

### 2.5. H-Bridge Inverter

The six outputs of the converters are connected as an input dc supply to the H-Bridge inverters[8] instead of distinct dc sources for each bridge as presented in Fig.5.

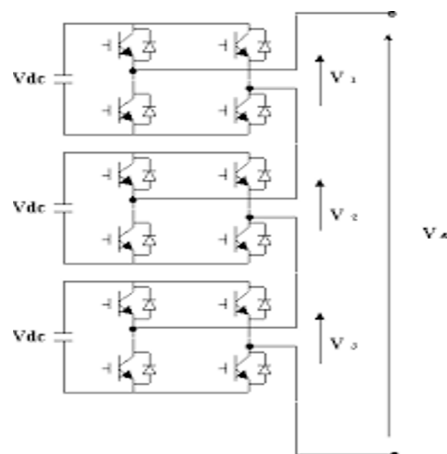

Fig.5 Multi-Level H-Bridge Inverter

### 3. Simulation Results

Simulation results are presented for the validation of proposed ideas. Simulink model of three levels and five levels H-bridge inverter has been built with a single PV panel. The parameters considered are mentioned in the Table 1.

Table 1. System Parameters

Parameter	Value
Inductors $L_1, L_2$	500uH
Capacitors $C_1, C_2$	20uF
Load Resistance R	20ohms
Filter Inductance L	15mH
Filter capacitance C	470uF
Switching Frequency f	100kHz

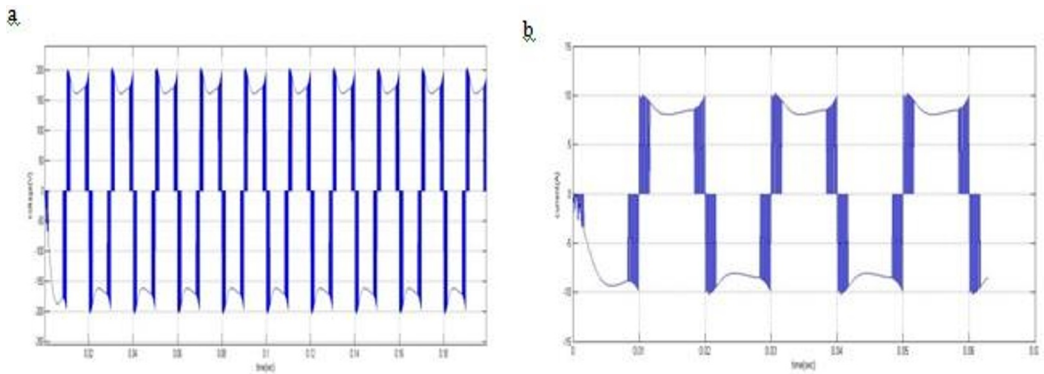

Fig.6 (a) three level –voltage without filter : (b) three level –current without filte.

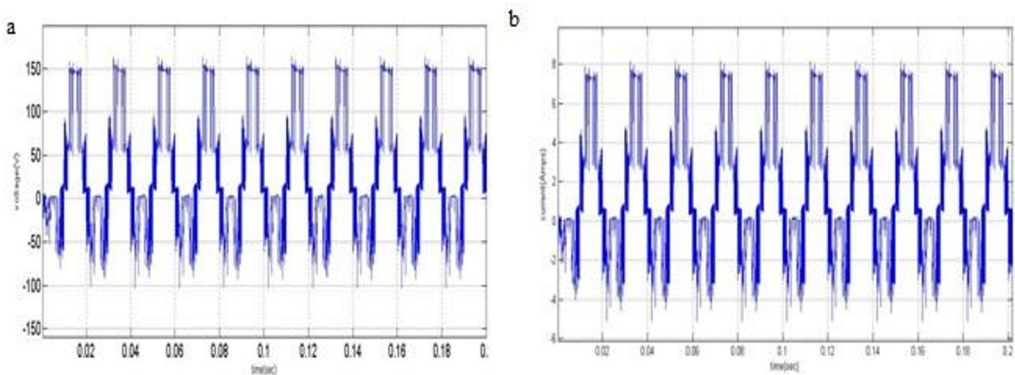

Fig.7 (a) five level-voltage without filter ; (b) five level- current without filter

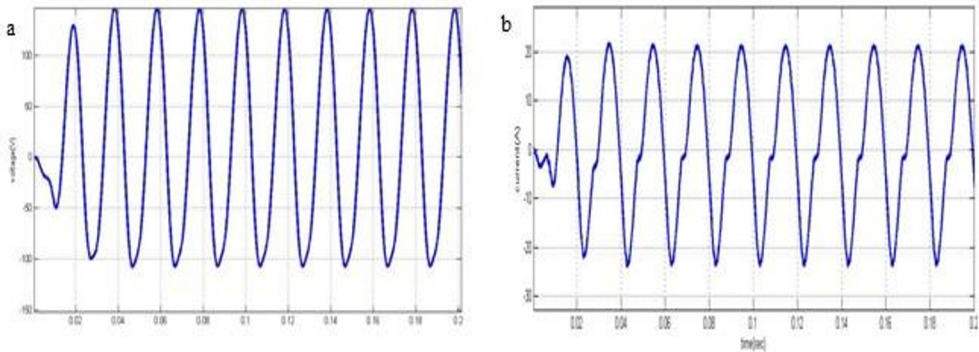

Fig.8 (a) five level –voltage with filter ; (b)five level- current with filter

Fig.6(a) and Fig.6(b) represents the voltage and currents of three level inverter without L and C filters respectively. The THD is about 36.01%. In order to reduce the harmonic content in the current and voltages L and C are added which act as filter to smoothen the output.

Fig.7(a) and Fig.7(b) shows the voltage and current waveforms of five level inverter without a filter which results in a THD of 70.82%. Fig.8(a) and Fig.8(b) gives the voltage and current with filter which reduces the THD.

#### 4. Conclusion

In this paper, simulation of SIMO based DC-DC converters for three and five level solar PV inverter is presented. This model aptly reduces the usage of distinct dc supplies for higher level inverters which thereby helps in reduction of number of PV panels. It yields good voltage and current levels with considerable efficiency and also a finds a greater place in the solar applications.

#### References

- [1] J.S.Lai and F.Z. Peng, “Multilevel converters-A new breed of power converters,” *IEEE Trans.Ind.Appl.*,vol. 32, no.3, pp.509-517,May/jun. 1996
- [2] J.M. Carrasco, L.G. Franquelo, J.T. Bialasiewicz, E. Galvan, R.C.PortilloGuisado, M.A.M. Prats,J.L. Leon and N.Moreno-Alfonso, “Power-electronic systems for grid integration of renewable energy resources: A survey,” *IEEE Trans.Ind.Electron*, vol.53, no.4,pp 1002-1016, Aug.2006
- [3] S.S Fazel, S.Bernet, D.Krug, and K.Jalili, “Design and comparison of 4-KV neutral-point-clamped, flying capacitor, and series-connected H-bridge multilevel converters,” *IEEE Trans.Ind.Appl.*, vol.43, no.4, pp.1032-1040, Jul./Aug. 2007.
- [4] Bailu Xiao, Lijun Hang, Jun Mei, Cameron Riley, Leon M.Tolbert, and Burak ozpineci, “Control of cascaded h-bridge multilevel inverter with individual MPPT for grid-connected photo voltaic generators,” *IEEE Trans. Ind. Appl.*, vol.51, no.2, pp.3715-3716, Aug./Sep. 2012.
- [5] Angel J.Soto,Esteban, O. Lindstrom, Fortunato Carlos Dualibe, Alejandro R. Orliwa, Pablo S. Mandelosi, “Design and Simulation of the control Architecture of a fully

- integrated SIMO DC-DC converter,” *Argentina school of micro-nano electronics, technology, applications* pp.64-69,2014.
- [6] Sandeep Patil, Srinivasa vemuru, Vijay Devabhaktuni, Khalid Al-Olimat,“Comparison of multilevel DC-DC converter topologies,” *IEEE Trans. On Latin Amer.*,2013.
- [7] H.G. Chiacchiarini, J G. Ceci, A R. Oliva, Pablo Sergio Mandolesi, “Cuk Converters for balanced power extraction in photo voltaic panels,” *IEEE Trans. Latin Amer.*,vol.14, pp-2611-2617. 2016.
- [8] Bailu Xiao, Lijun Hang, Jun Mei, Cameron Riley, Leon M.Tolbert, and Burak ozpineci, “Modular cascaded H-bridge multi level PV inverter with distributed MPPT for grid connected applications *IEEE Trans. Ind. Appl.*, vol.51, no.2, pp.-3716, Mar./Apr. 2015.
- [9]. Koilada Rajesh, “Novel Control of Boost Converter for MPPT of Wind Turbine”, *International Journal of New Technologies in Science and Engineering (IJNTSE)*, Vol. 8, Issue. 6, pp. 1-6, June. 2022.