

# Optimal Energy Storage scheduling of Microgrid by Using Ant colony optimization

Khushboo Sharma, Prabhu A, Sheryl Gupta and Kuldeep Singh Kulhar

Khushboo Sharma, Assistant Professor, Electrical Engineering, Vivekananda Global University, Jaipur, India, Email Id-khushboo.sharma@vgu.ac.in

Prabhu A, Associate Professor, Department of Computer Science and Information Technology, Jain (Deemed to be University), Bangalore, India, Email Id-prabhu.a@jainuniversity.ac.in

Ms. Sheryl Gupta, Scholar, Department of Management, Sanskriti University, Mathura, Uttar Pradesh, India, Email Id-sherylg.somc@sanskriti.edu.in

Kuldeep Singh Kulhar, Professor, Civil Engineering, Vivekananda Global University, Jaipur, India, Email Id-k.singh@vgu.ac.in

**Abstract:**Energy storage device such as battery is playing very important aspect in microgrid since it can handle the bidirectional power flow to stabilize the power quality issues. Renewable energy sources based microgrids are becoming popular now a day because of those arte main networks which are playing key role in reduction of global warming as well as main power sources for many areas in world wide. The PV and wind based power generation systems are wildly used sources in microgrids. Unfortunately, these sources are depends on whether condition and cannot have a stable output to supply quality power to consumers. Therefore an storage device is must to incorporate in such kind of microgrids. Hence it is very important to have an optimization of scheduling a day-ahead energy storage system in case of renewable energy sources based microgrid power supply system. Ant colony optimization is one of the best optimization techniqueto get feasible solution for complexity networks such as microgrids. The data demonstrate the utilization of ant colony optimization technique in order to minimize microgrid expenses under a time-of-use tariff system. The findings also indicate the influence of the microgrid's self-reliance and the storage system's capability on the energy expenses of the microgrid.

**Keywords:** Ant colony optimization, Scheduling, energy storage device, microgrids.

---

Corresponding Author: khushboo.sharma@vgu.ac.in

## 1. Introduction

Receiving quality electrical supply without any interrupt with minimum cost is every one's right in these days [1]. In the same way, the reduction of emission of carbon productions is also essential for better life to live in society. The awareness on usage of renewable energy sources worldwide has been increased day by day due to their merits. Among many available renewable energy sources in nature, photovoltaic (PV) and wind energy sources based electrical power generation systems are very famous in many places since the easiest establishments in any location. Electrical power generation from these sources are depends on nature and having random changes in output. Hence, energy storage system (ESS) is required to stabilize electrical output power which is generated from renewable [1-3] energy sources.

All microgrids are required ESS for supplying stable power to consumers without any interrupt. Therefore the scheduling of ESS for a day ahead is essential for supplying quality power to loads with minimum operating cost; hence it can minimize the electricity bill. The limitation of state of charge (SoC) is very important for maximizing the list of ESS in microgrids. Dynamic valuing of power is progressively getting more consideration as a method for instigating top shaving and burden evening out, by normally estimating power higher during times of popularity, in this manner boosting purchasers to diminish their interest around then and reshaping the heap bend. To achieve the best feasible solution for scheduling of ESS can be done by using any optimization technique. Among many optimization techniques, ant colony optimization (ACO) is attracting many researchers in solving complexity functions. The paper presents the application of ACO in reduction of energy bill of microgrid.

## 2. Objective Function

The generalized block diagram of microgrid is shown in Fig. 1 with renewable energy sources and ESS. The main objective is reduce the electrical energy bill of the microgrid by scheduling a day ahead system of ESS with the help of ACO.

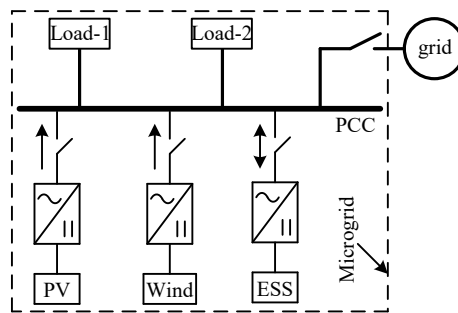

Fig. 1: Renewable energy and ESS based microgrid

The daily microgrid energy bill ( $E_{bill}$ ) will be calculated as the variance between daily costs and revenue. Positive  $E_{bill}$  values will signify an amount to be paid, while negative values will indicate an amount to be received or converted into energy credits.

$$E_{bill} = -\Delta t \sum_{t=1}^n P_{sel}^t p_{sel}^t + \Delta t \sum_{t=1}^n P_{pur}^t p_{pur}^t + \Delta t \sum ESS_{cost} + MC$$

(1)

Where,  $-\Delta t \sum_{t=1}^n P_{sel}^t p_{sel}^t + \Delta t$  is revenue from sale of micro grid energy,  $\Delta t \sum_{t=1}^n P_{pur}^t p_{pur}^t$  is cost due to purchase, MC represents microgrid cost involves operational, maintenance and fixed.

The main aim of optimizing the storage and load dispatch of a system consists of minimizing its daily energy bill, hence this can be expressed by:

$$\min E_{bill} = C_{pv,wind} + \sum_{t=1}^n \left( \begin{array}{l} st_{pur}^t c_{pur} + st_{sel}^t c_{sel} + \\ \sum_{j=1}^M (st_{pur}^{j,t} c_{pur} + st_{sel}^{j,t} c_{sel}) + \\ st_{shd}^t c_{shd} + st_{int}^t c_{int} + st_{chr}^t c_{chr} + \\ \Delta t \left( \begin{array}{l} P_{gen}^t p_{gen} + P_{chr}^t p_{chr} + P_{dch}^t p_{dch} - \\ P_{sel}^t p_{sel} + P_{shd}^t p_{shd} + P_{int}^t p_{int} \end{array} \right) \end{array} \right) \quad (2)$$

In order to minimize the cost of electricity bill, the above equation needs to be optimized.

### 3. Ant Colony Optimization

The ACO algorithm is a stochastic method used to tackle computational problems that can be simplified to identifying viable solutions for intricate functions. Artificial ants represent multi-agent techniques that draw inspiration from the actions of actual ants. The ACO algorithm consists of three components: constructing solutions based on ants, updating pheromones, and iterating. Hence, the algorithm of ACO can give effective and fast solution to the cost function of scheduling of day ahead energy storage system in microgrid. The formal ACO flow chart is depicted in Fig.2. The solution can give best cost function of ESS of microgrid.

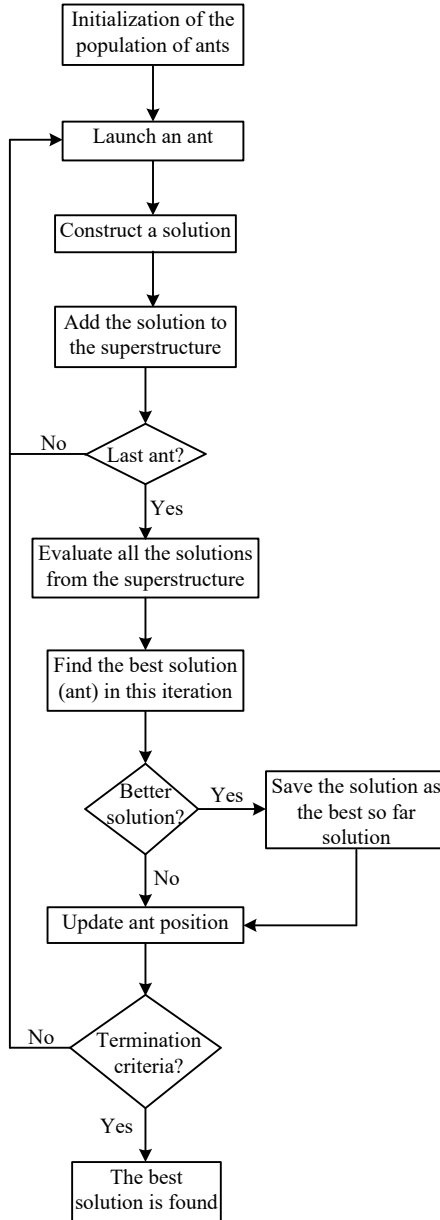

Fig. 2: Flow chart for ant colony optimization

The pheromone update function can be expressed as

$$T_{xy} \leftarrow (1 - \rho)T_{xy} + \sum_k \Delta T_{xy}^k \quad (3)$$

The equation (3) is more suitable to solve equation (2) with proper ACO algorithm. The left side on the equation indicates the amount of pheromone on the given edge x,y.

Marco Dorigo is developed ACO on during his research work based on the foraging behavior of an ants for identifying a shortest path between food to their colony. This is further implemented and developed for using in many optimizing methodologies for

solving complex problems. Ants are social insects and likely live in colonies around us. The way of behaving of the insects (ants) is constrained by the objective of looking for food. The subterranean insect repeatedly leaps from one location to another in order to locate its food source. During its movement, it deposits a naturally occurring substance known as pheromone onto the surface. Subterranean insects communicate amongst themselves through the utilization of pheromone trails. Upon returning from the food source, it deposits pheromones along the paths based on the quantity and quality of the food. Underground insects have the ability to detect pheromones. In this manner, various insects are able to detect the scent and track it accordingly. The probability of choosing a particular path increases with a higher level of pheromones, and as more insects follow that path, the amount of pheromones on that path will also increase.

#### 4. Implementation of the system

Many scholars are proposed different optimization techniques in their research papers. Optimal scheduling for battery storage system for microgrid is proposed by authors in [1]. In [2], authors were proposed genetic algorithm and particle swarm optimization techniques for a day ahead energy storage system scheduling in microgrid. Authors concluded that particle swarm optimization technique can give feasible solution than genetic algorithm because of its superiority. stochastic MILP-Based bi-objective optimization approach for electrical networks to optimize scheduling of energy storage system was proposed by authors in [3]. Day-Ahead Economic Optimal Dispatch of Microgrid Cluster is proposed in [4] where considering Shared Energy Storage System.

The code for pheromone update is given below:

```
Publicvoid,
calculate Probabilities(Ant ant){ inti = ant.trail [current Index];
double pheromone = 0.0; for (int l = 0; l < number of Cities; l++) { if (!ant.visited(l)){
pheromone += Math.pow(trails[i][l], alpha) * Math.pow(1.0 / graph[i][l], beta); } }
for (int j = 0; j < number of Cities; j++) { if (ant.visited(j)) { probabilities[j] = 0.0; }
else
{ double numerator = Math.pow(trails[i][j], alpha) * Math.pow(1.0 / graph[i][j], beta);
probabilities[j] = numerator / pheromone; } } }
```

#### 5. Results and discussions

The results are carried out on MATLAB platform for the system with ACO technique as follows.

The SoC of the battery is very important and its indicates the charging and discharging. The response of SoC is plotted in Fig. 3 with ACO and PSO for scheduling energy storage device function. From Fig. 3, the ACO can give less time for discharging and can save more energy, and then the cost will be automatically reduced by using ACO.

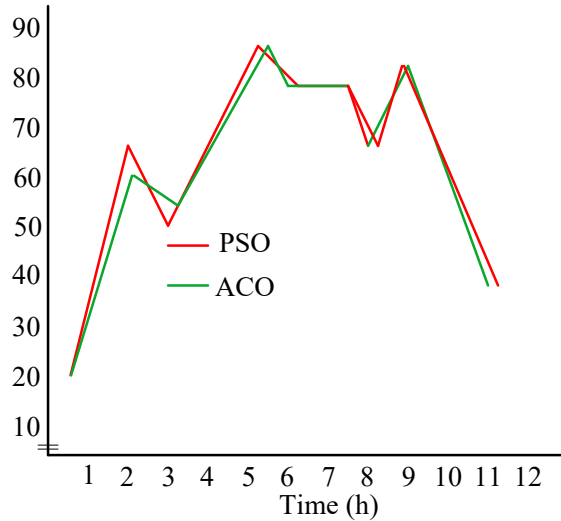

Fig. 3: Hourly SOC of battery with PSO and ACO

The cost of system in per units is considered and compared ACO with PSO for scheduling energy storage device. The corresponding response with number of iterations is depicted in Fig. 4. From Fig. 4, it is consumed that the number of iterations are less in ACO to reach minimum cost as compared with PSO.

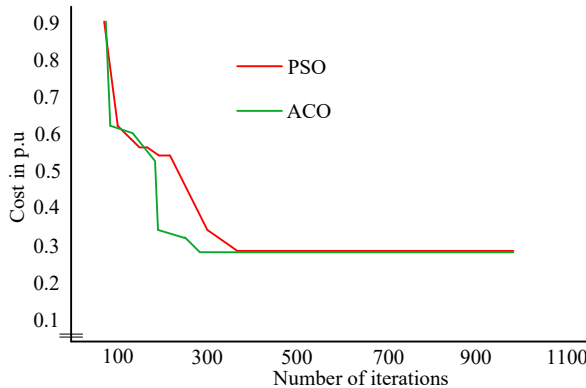

Fig. 4: response of Cost vs number of iteration in ACO and PSO

## 6. Conclusion:

The ant colony optimization technique is proposed for a day ahead energy storage system scheduling (such as battery) in microgrid in this paper. The responses of SoC of battery and cost function of system is given and compared with PSO. This kind of scheduling is very important in renewable energy sources based microgrid for future planning. This can help to supply quality power to consumers without any interrupt. The proposed method also can maximize battery life time.

## References:

- [1] Vanderlei AparecidoSilva , Alexandre Rasi Aoki, and Germano Lambert-Torres, “Optimal Day-Ahead Scheduling of Microgrids with Battery Energy Storage System”, *Energies*, Volume 13, 2020.
- [2] Ajay Raghavan, PaarthMaan, and Ajitha K. B. Shenoy, “”, *Optimization of Day-Ahead Energy Storage System Scheduling in Microgrid Using Genetic Algorithm and Particle Swarm Optimization*”, *IEEE Access*, Volume 8, 2020.
- [3] M. Eslahi A. ForoughiNematollahi B. Vahidi, “Day-Ahead scheduling of centralized energy storage system in electrical networks by proposed stochastic MILP-Based bi-objective optimization approach”, *Electric Power Systems Research*, Volume 192, 2021.
- [4] Cao Siming, Zhang Hanlin, Cao Kai, Chen Meng, Wu Yi, Zhou Suyang, “Day-Ahead Economic Optimal Dispatch of Microgrid Cluster Considering Shared Energy Storage System and P2P Transaction”, *Frontiers in Energy Research*, Volume 9, 2021.
- [5] C. M. Colson, M. H. Nehrir and C. Wang, "Ant colony optimization for microgrid multi-objective power management," *2009 IEEE/PES Power Systems Conference and Exposition*, 2009, pp. 1-7, doi: 10.1109/PSCE.2009.4840070.
- [6] MousaMarzbandab, EbrahimYousefnejadb, Andreas Sumperd, and José Luis Domínguez-Garciac, “Real time experimental implementation of optimum energy management system in standalone Microgrid by using multi-layer ant colony optimization”, *International Journal of Electrical Power & Energy Systems* Volume 75, 2016.
- [7] M. I. Henderson, D. Novosel, and M. L. Crow, “Electric power grid modernization trends, challenges, and opportunities,” in *Proc. IEEE Technol. Trend Paper*, 2017, pp. 1–17.
- [8] A. Ahmad, N. Javaid, A. Mateen, M. Awais, and Z. A. Khan, “Shortterm load forecasting in smart grids: An intelligent modular approach,” *Energies*, vol. 12, no. 1, p. 164, Jan. 2019
- [9] S. Esmacili, A. Anvari-Moghaddam, and S. Jadid, “Optimal operational scheduling of reconfigurable multi-microgrids considering energy storage systems,” *Energies*, vol. 12, pp. 1–21, May 2019.
- [10] K. B. AjithaShenoy, S. Biswas, and P. P. Kurur, “Efficacy of the metropolis algorithm for the minimum-weight codeword problem using codeword and generator search spaces,” *IEEE Trans. Evol. Comput.*, vol. 24, no. 4, pp. 664–678, Aug. 2020.