

TSK-Fuzzy Controllers based Novel Control Method for Grid Integrated DFIG System

Amandeep Gill, Adlin Jebakumari S, Aasheesh Raizada and Kuldeep Singh Kulhar

Amandeep Gill, Dean R&D, R&D Cell, Vivekananda Global University, Jaipur, India,
Email Id-amandeep.gill@vgu.ac.in

Adlin Jebakumari S, Assistant Professor, Department of Computer Science and Information Technology, Jain (Deemed to be University), Bangalore, India, Email Id-
j.adlin@jainuniversity.ac.in

Dr. Aasheesh Raizada, Assistant Professor, Department of Computer Science Engineering, Sanskriti University, Mathura, Uttar Pradesh, India, Email Id-
aasheesh.cse@sanskriti.edu.in

Kuldeep Singh Kulhar, Professor, Civil Engineering, Vivekananda Global University, Jaipur, India, Email Id-k.singh@vgu.ac.in

Abstract-Grid connected renewable energy sources based electric power generation systems are increasing day by day to meet the electrical demand without burning any fossil fuels. Doubly fed induction generators (DFIGs) are widely used in wind turbines due to advantages that they can allow the amplitude and frequency of their output voltages to be maintained at a constant value, no matter the speed of the wind blowing on the wind turbine rotor. Moreover, the DFIG provides a huge possibility to improve network dynamic behavior by using the power electronic converters with sufficient control arrangements. Many different structure and control algorithms can be used for control of power converters. However, conventional controllers cannot perform with full efficiency during rapid changes in wind speed. Hence, Takagi–Sugeno–Kang (TSK) Fuzzy controllers based novel control technique is proposed in this paper for performing many tasks on grid connected DFIG systems. The proposed control scheme is tested under variations of voltage, frequency, wind speed, and reactive power load. To achieve the realistic responses, the Hardware-in the-Loop (HIL) is implemented with the help of OPAL-RT modules for presenting extensive results.

Keywords: DFIG; Renewable Energy; TSK-Fuzzy; Grid Connected System; HIL; OPAL-RT.

Corresponding author: amandeep.gill@vgu.ac.in

1. INTRODUCTION

Renewable energy sources are prompting applications in generation of electrical power to reduce global warming. Electricity production by using renewable energy sources is globally increasing day by day to meet load demand without emission any toxic gases [1-3]. The wind energy is a best renewable energy source to produce electricity since its availability at any locations. Wind energy based electrical power generation systems can be established in both offshore as well as onshore. The lifetime of wind energy conversion systems are more and required very less operating cost. A turbine is mainly used to converter wind velocity to mechanical energy and this mechanical energy further used as input to electrical generator for production of electricity. Much kind of generators are available to use in wind energy conversion system. Apart from many, doubly fed induction generator (DFIG) with back to back converter is widely used for high power rating system [4]. The DFIG systems with proper controlling mechanism can enables wind turbines to operate under various ranges of wind speeds. Especially DFIG systems are using for high power generation system. Due to variable wind speed, a back to back converter technique is required to connect DFIG based wind power generation system into utility power grid. Hence, precious control mechanism needs to be implementing on these converters to make system more stable and economical. Many controlling techniques are implemented on converters and most of the techniques are using conventional proportional plus integral (PI) controllers. But, PI controllers cannot excicute accurate output during random changes due to their fixed gains tuned at particular instant [5]. Hence, a Fuzzy based control techniques needs to be developed to produce best performance of the system under random changes in the system. However, mamdani type Fuzzy controllers are complex and required more computational time than Takagi–Sugeno–Kang (TSK) Fuzzy controllers [6-7]. In addition to this, a maximum power point tracking (MPPT) mechanism is required on wind turbine to harvest maximum energy during all the possible conditions. Therefore, an integrated hybrid control technique with help of TSK fuzzy controllers is developed on back to back converters to work as a MPTT device for wind turbine as well as transfer active power to grid in this paper. The generated real power should be transferred to utility grid as the reactive power compensation also required operating local loads without consumption of any extra reactive power through grid. This methodology can also improve the power quality. Further, it is very difficult to measure the speed f wind turbine, hence implementing of sensorless control for MPPT on shaft of the DFIG can give best performance as well as economical. A sensorless MPPT control on rotor side converter and double loop vector control on grid side converter are implemented with the help of TSK-Fuzzy controllers in this paper.

The paper is organizing with following sections. Description of the system is providing in Section-2, designing of TSK fuzzy controller is given in Section-3. The proposed methodology is presented in Section-4. Results are compressed and presented with the help of establishing Hardware- in the – Loop (HIL) by using OPAL-RT technologies in section-5. Conclusion is mentioned in Section-6. Parameters of various components involved in the system are listed in Appendix.

2. Description of the System

The layout of grid connected DFIG system with back to back converter is depicted in Fig. 1. Two power electronics converters are required, one is on rotor side and another should be interfaced on grid side with the help of transformer and these both converters should be

connected with a common dc-link. Proper MPPT algorithm is required to identify the maximum power location. The Perturb and Observe (P&O) technique is popular required only voltage and current to identify the best operating condition for extracting maximum energy. Hence, the P&O algorithm is implemented on rotor side converter. Moreover, the speed sensorless methodology is implanted to estimate the speed of the DFIG without using any sensors for measuring the speed. The control of reactive power is also adopted through control mechanism of rotor side converter. The voltage across dc-link (voltage between two converters) is regulated through grid side converter. Local side loads are operated across PCC. A gear system is incorporated between wind turbine and shaft of the DFIG to maintain required speed. A two mass model of wind turbine is considered in this paper from references [2] to obtain more realistic responses. An 11kV system is established; hence the DFIG is interconnected to utility grid. Similar kinds of systems are proposed by many scholars recently and few of them listed below.

Authors in [8] implemented a coordinated control and reactive current constraints of DFIG system during asymmetric grid conditions. Stability analysis of grid connected DFIG system with voltage source converter based HVDC model is presented by authors in [9]. Authors in [10] proposed a sliding mode control of DFIG system by considering harmonically and unbalanced grid profile. A novel MPPT and battery energy management system are developed on grid connected DFIG system by authors in [11]. Grid connected Battery-PV-Wind driven DFIG system is implemented by authors in [12] to improve the power quality under different operational conditions. Voltage control of DFIG system connected to weak grid is proposed by authors in [13] with the help of improved fractional order damping method. Authors in [14] proposed a new control strategy of the grid connected DFIG system to serve multiple purposes and also analyzed the system during faults as well as in isolated mode. A unified power control method is implemented on DFIG system under both grid and standalone mode by authors in [15]. However, authors are not used TSK-Fuzzy controllers to achieve the better response. Further authors not considered the power quality factors under random changes as well as not implemented sensorless control method on MPPT of wind turbine through rotor side converter of DFIG system.

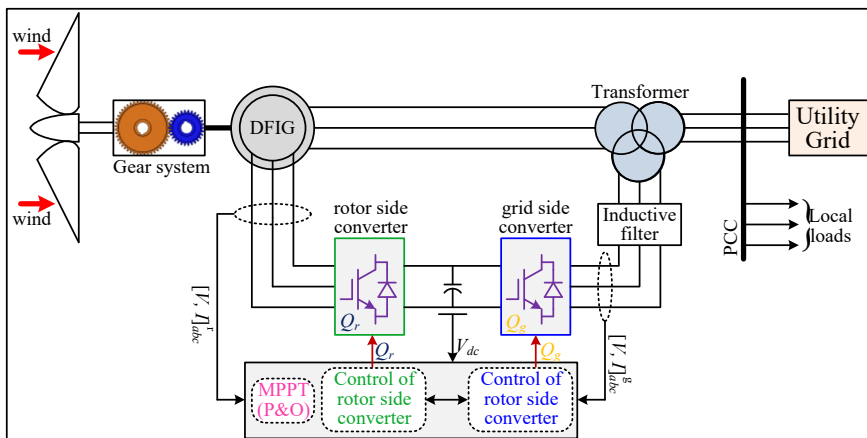

Fig. 1: Model layout of grid connected DFIG System.

This paper is presented to fulfill following list of objectives.

- Design TSK-Fuzzy controllers to use in proposed control methods.
- Sensorless control of MPPT is implemented on rotor side converter to extract maximum power from wind turbine without sensing any speed of the turbine.

- Reactive power management is done through rotor side converter to regulate speed of the DFIG.
- Reactive power compensation for local loads connected at point of common coupling (PCC) is achieved through proposed control scheme on grid side converter.
- Power quality at PCC is improved as well as obtained fast response under random changes in wind speed by proposed control method.

3. Design of TSK-Fuzzy Controllers

Accurate reference signal from error signal may not be generated through conventional PI controllers due to their fixed gains during sudden changes in system [5]. Generally gains of PI controllers are tuning at particular condition. To avoid this situation, a TSK-Fuzzy controller is adopted which can adjust their gains automatically by applying any machine learning technique. Therefore, the TSK-Fuzzy controller is enough capable to produce accurate signal in any situation of changes occurred in the system. Hence, the designed TSK-Fuzzy controller will produce superior performance than conventional PI controller during all conditions [5, 16-17]. A trained artificial neural network (ANN) based learning algorithm is applied to the TSK-Fuzzy system to get fastest update procedure of weights. The generalized model of TSK-Fuzzy controller which depicted in Fig. 2 is adopted from [5, 16-17]. Respective rules – Weight sketch is presented in Fig. 3. The error and its derivative are considered as two inputs of the TSK-Fuzzy system.

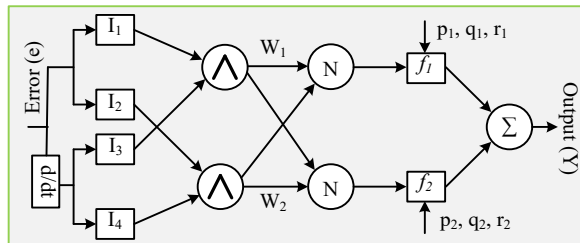

Fig. 2: Model diagram of ANN interfaced TSK-Fuzzy system.

The mathematical expressions of the TSK-Fuzzy system is given by eq. (1)-(3)

$$Y = W_1^n f_1 + W_2^n f_2 \quad (1)$$

$$f_1 = p_1 X_1 + q_1 X_2 + r_1 \quad (2)$$

$$f_2 = p_2 X_1 + q_2 X_2 + r_2 \quad (3)$$

Where, $p_{1,2}$; $q_{1,2}$; $r_{1,2}$ are constants which are tuned parameters.

Required weights of the system is updating every time automatically by a trained ANN network to achieve enough fast response during all conditions. The designated TSK-Fuzzy controllers can be easily used in control methods of converters in grid connected DFIG system. The error signal will be given to the TSK-Fuzzy controller to produce corresponding reference signal in respective control method.

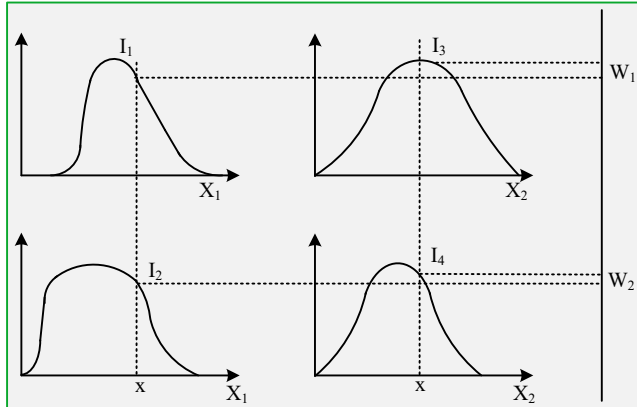

Fig. 3: TSK-Fuzzy rules-weight functions.

Two nonzero possible functions ($\mu_1(x_i)$ and $\mu_2(x_i)$) are considered while designing the TSK-Fuzzy system as follows:

$$f(x) = \frac{\sum_{m=j_1}^{j_1+1} \dots \sum_{m=j_n}^{j_n+1} \left(\prod_{i=1}^n \mu_i(x_i) \right) C_{m_1 \dots m_n}}{\sum_{m=j_1}^{j_1+1} \dots \sum_{m=j_n}^{j_n+1} \left(\prod_{i=1}^n \mu_i(x_i) \right)} \tag{4}$$

Where denominator is usually considered as unity because of normality and consistency of the fuzzy sets.

Therefore,

$$\mu_1(x_i) + \mu_2(x_i) = 1 \tag{5}$$

Actually the TSK-Fuzzy controller designed for this system is two input and single output system. Hence,

$$f(x) = C_{j_1 j_2} + (C_{j_1+1, j_2} - C_{j_1 j_2}) \mu_1(x_1) + (C_{j_1, j_2+1} - C_{j_1 j_2}) \mu_2(x_2) + (C_{j_1 j_2} - C_{j_1, j_2+1} - C_{j_1+1, j_2} + C_{j_1+1, j_2+1}) \mu_1(x_1) \mu_2(x_2) \tag{6}$$

Generally the membership functions are defined as:

$$\mu_1(x_1) = \frac{1}{h_1} (x_1 - x_1^0) \text{ and } \mu_2(x_2) = \frac{1}{h_2} (x_2 - x_2^0) \tag{7}$$

Where, $x_1^0 \leq x \leq x_1$ for positive membership and $x_2^0 \leq x \leq x_2$ for negative membership.

$$h_i = x_i - x_i^0 .$$

The above equation (7) can be further represented in graphical model as shown in Fig. 4.

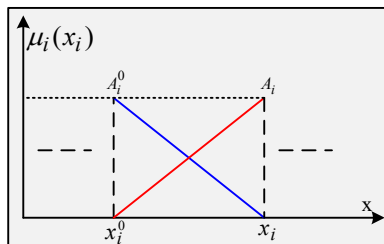

Fig. 4: Graphical representation of membership function.

4. Proposed Control Method

Novel control techniques are proposed for both rotor side converter (RSC) and grid side converter (GSC) in this paper by using TSK-Fuzzy controllers. The P&O based MPPT algorithm is also incorporated on the control method of RSC to work as a MPPT device on wind turbine through regulating speed of the DFIG. The speed of the DFIG is estimated through direct and quadrature (d&q) components of voltage and current. Hence, this technique can avoid an extra sensor for sensing the speed of DFIG/wind turbine. The designed TSK-Fuzzy controllers are used to estimate required dq current components (I_{dq}) on rotor side of the DFIG. Further these reference components are used to generate required pulses for RSC through a hysteresis loop since the speed of the rotor can be regulated through controlling the rotor current. The reactive power required by DFIG is also considered as reference reactive power component, hence the RSC can also act as reactive power supply of generator. The control scheme of RSC is shown in Fig. 5.

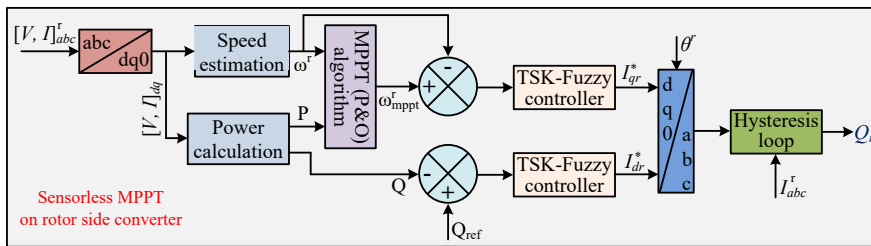

Fig. 5: Integrated control scheme of RSC using TSK-Fuzzy controllers.

Similarly, a grid side converter (GSC) is incorporated with grid through a three phase interfacing transformer. A double loop vector control with the help of TSK-Fuzzy controllers is implemented on GSC to maintain constant voltage at dc-link. The grid currents are incorporated into proposed control scheme for making as reactive power compensator device. The reactive power component (I_q) of grid is compared to zero, hence, the converter can compensate complete reactive power demanded by the load. Therefore, grid no needs to supply any reactive power to local loads. Further, this proposed controller can also maintain power quality at local load bus by maintaining constant voltage. The reference dq components of voltages on GSC are obtained through respective TS-Fuzzy controllers. Space vector pulse width modulation (SVPWM) technique is used to generate required pulses, this can help GSC to make synchronization with grid. Proposed control scheme of the GSC is shown in Fig. 6.

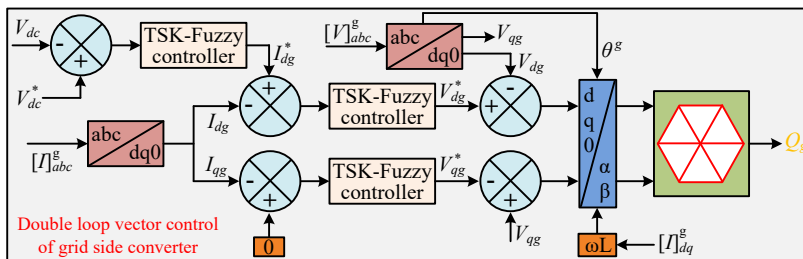

Fig. 6: Control scheme of GSC with the help of TSK-Fuzzy controllers.

5. Results and Discussions

A phasor type of proposed model is designed by using Simulink package on MATLAB platform. Further this model is divided into two parts for making HIL configuration by using OPAL-RT platform. In order to replicate real-time performance, real-time digital simulator (RTDS) modules are utilized to simulate the proposed model and showcase the results. The RTDS module possesses sufficient capability to solve intricate power system equations in a manner that closely resembles real-time scenarios [1, 5]. Consequently, it has gained widespread acceptance among numerous scholars worldwide for the purpose of testing power system components. The RTDS integrates cutting-edge computer hardware with extensive software capabilities. The hardware architecture features parallel processing and is constructed using modular units. Every module consists of processing and communication components.

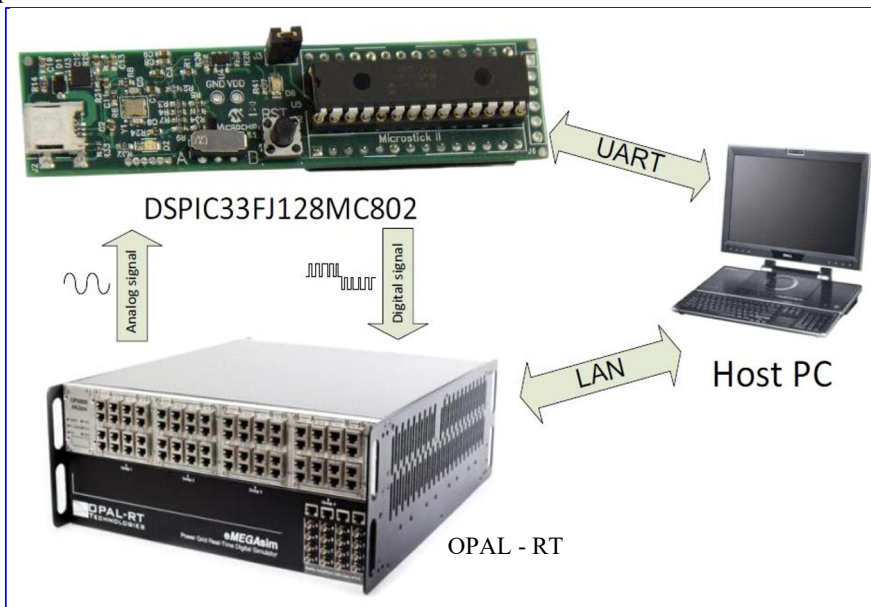
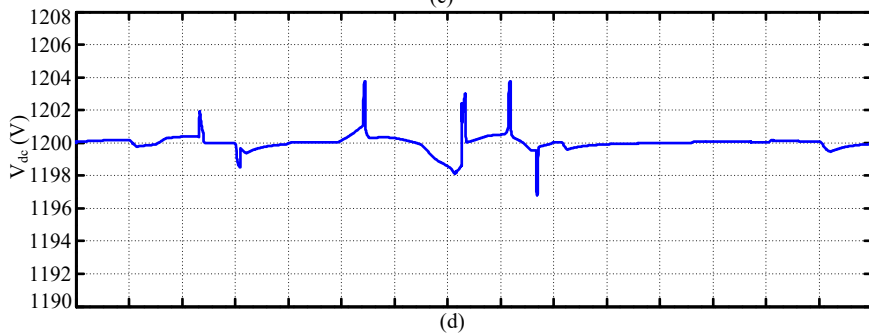
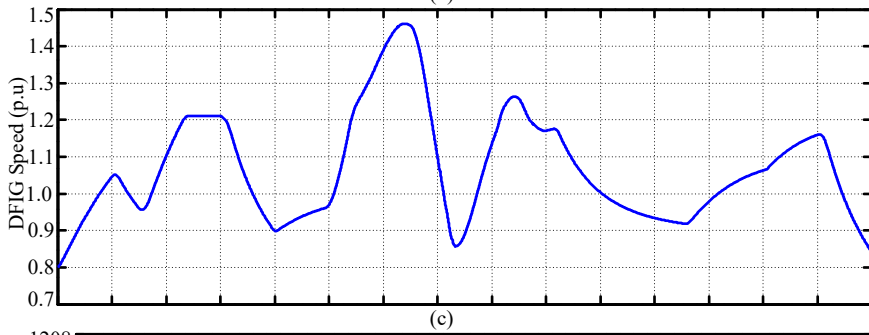
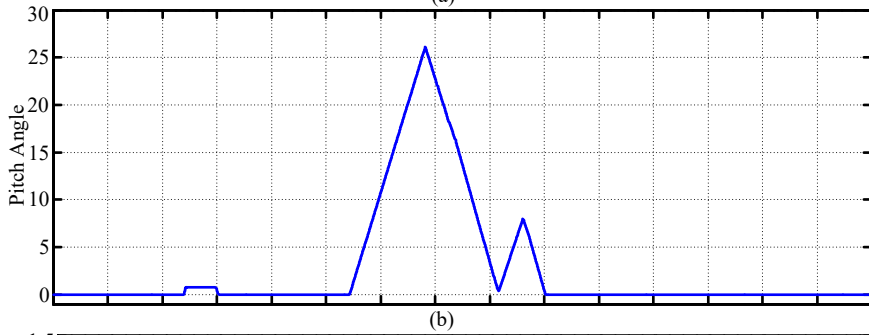
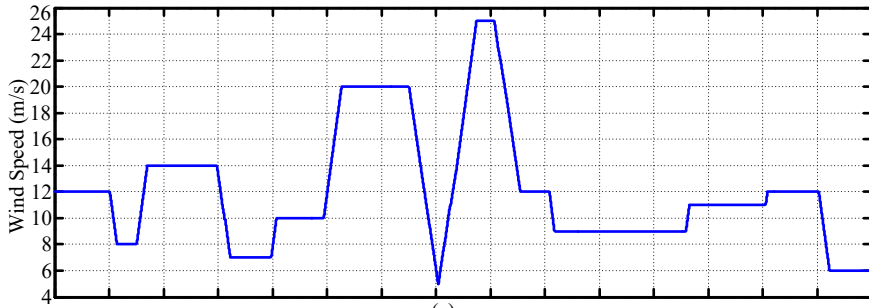

Fig. 7: HIL connections by using OPAL-RT units.

Numerous researchers are utilizing DSP/microcontroller based two RTDS devices interconnected with appropriate data cables to establish the HIL setup. Two RTDS modules created by OPAL-RT technologies are linked via appropriate channels to form a HIL setup for the proposed model. Figure 7 illustrates the overall configuration of the HIL setup, which is designed using the OPAL-RT module. The system depicted in Figure 1 is partitioned into two components: the plant and the controller unit. The plant model consists of all loads, grid, converters, transformers, and other electrical components etc while controller unit consists of all control techniques of RSC and GSC. The plant's command signals are transformed into digital signals in order to serve as an input for the controller unit. The controller unit's output signals are transformed into analog signals to be used as input for the plant unit. Therefore, it created a self-contained circuit to evaluate the effectiveness of the suggested control methods in attaining a comparable outcome to that of the real-time model. The RTDS unit is employed for the processing of the plant, while the execution of the control scheme is carried out within the microcontroller. The complete process of the HIL is performed to analyze the significance of proposed control methods. To examine the output waveforms, the responses of different signals are gathered in a computer using the MATLAB package.

While testing the model presented in Fig. 1, a transformer is connected between AC load bus and grid and several transmission lines also considered to achieve the response similar to real time. A 9MW DFIG system is modeled with the help of [18-19] and the system parameters are listed in Appendix. Other parameters of system are considered from [20]. The designed model is tested under variable wind speed. Various changes and values of wind velocity are considered to test the performance of the proposed method. Above and below base speeds also considered. Consider 12m/s is a cut of speed of the wind turbine. Hence, when the speed is above the cut of speed, the pitch angel controller can work to make the turbine for proper operation. The applied profile of wind speed is depicted in Fig. 8(a) which clearly shows some ramp type increasing/decreasing happen when changes the speed of wind. This kind of profile is more near to real time and also a two mass turbine model is incorporated in the system. Hence, some delay will occur in pitch angle controller and also can achieve slow dynamics of turbine as like real time model. Respective action of pitch angle control mechanism is shown in Fig. 8(b). Due to the effect of both pitch angel control and a two mass wind turbine model, the speed received by DFIG system (after gear system) in per unit (p.u) is shown in Fig. 8(c). Respective voltage at dc-link is presented in Fig. 8(d). During over speed (above cut of speed) of the wind, there is a small change in dc-link voltage for few seconds, however, proposed control schemes of converters make the dc-link voltage within the limit. The changes in dc-link voltage are not much more as those are under limit. Corresponding voltages (three phase in phasor representation) produced by DFIG is presented in Fig. 8(e). The voltage produced by DFIG is almost constant and under limit. There is a transformer along with transmission lines are incorporated between DFIG and grid. An unbalanced load is considered across the AC bus. Corresponding grid voltages are depicted in Fig. 8(f). There are very minor changes appeared in grid voltages according to changes happened in wind velocity, however voltages are almost constant. Corresponding real and reactive powers produced by DFIG are given in Fig. 8(g) and Fig. 8(h) respectively. Fast and precious responses of the system are obtained because of using TSK-Fuzzy controllers during rapid changes of wind velocity.



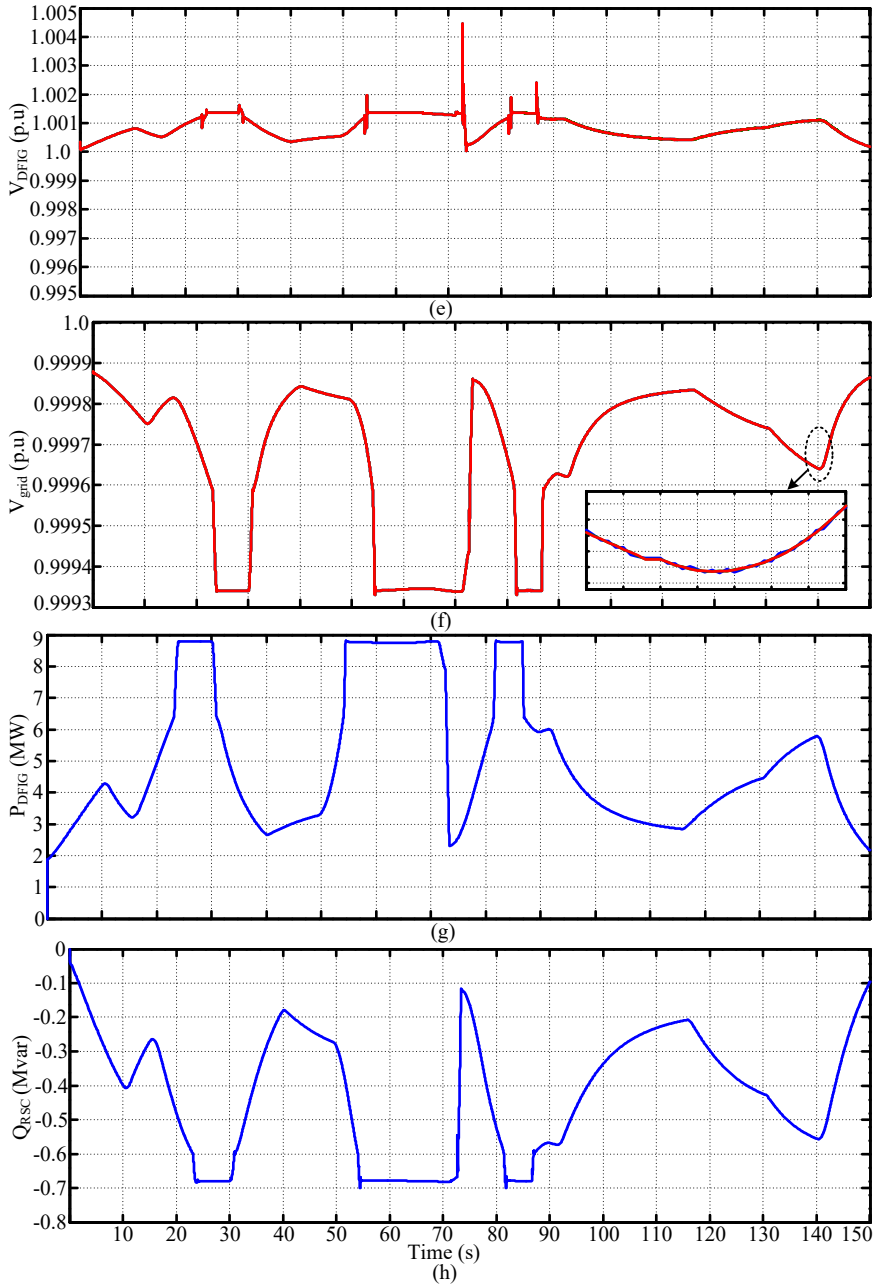

Fig. 8: Responses of (a) wind speed, (b) pitch angle, (c) speed of DFIG, (d) voltage at dc-link, (e) voltages produced by DFIG, (f) grid voltages, (g) real power generated by DFIG, (h) reactive power of DFIG.

6. Conclusion

TSK-Fuzzy controllers based control schemes are proposed for grid connected DFIG system in this paper. Speed sensorless method is adopted to build MPPT of wind turbine

through RSC of the DFIG system. Hence RSC of DFIG can also act as MPPT of wind turbine. Reactive power compensation is included in control method of the GSC. Machine learning based ANN method is used to update the gains of the controllers to achieve better responses under various changes in wind speed. Precious responses are obtained during random changes of wind velocity because of TSK-Fuzzy controllers. OPAL-RT modules are used to establish a HIL for presenting the results.

Appendix:

Table-1: Parameters of 9MW wind farm.

S.No	Parameter	Value.Unit
1	Rated power.	9MW
2	Rated Voltage.	575V
3	Frequency.	60Hz
4	Stator resistance.	0.023p.u
5	Rotor resistance.	0.016p.u
6	Magnetizing inductance.	2.9p.u
7	Stator leakage inductance.	0.18p.u
8	Rotor leakage inductance.	0.16p.u
9	Inertia constant.	5.04
10	Number of pole pairs.	2
11	Operating voltage at dc-link.	1200V

Table-2: Parameters of GSC and RSC.

S.No	Parameter	Value.Unit
1	Coupling inductor-GSC.	0.15p.u
2	DC-link capacitor.	60000 uF
3	Line resistance.	0.0015p.u
4	Switches.	IGBTs

Table-3: Turbine data.

S.No	Parameter	Value.Unit
1	Power rating-mechanical.	9MW
2	Power at point C..	0.73
3	Wind speed at point C	12m/s
4	Pitch angle gain.	500
6	Maximum pitch angel.	45 ⁰
7	Maximum rate of change of pitch angel	2 deg/s

Table-4: Control parameters.

S.No	Parameter	Value.Unit
1	Reference grid voltage.	1p.u
2	Droop X_s	0.2p.u
3	Reactive power regulator gain	0.05
4	Maximum change of converter reference current.	200pu/s
6	Maximum number of neurons considered.	50

References

- [1]. Siva Ganesh Malla, et al., "Coordinated power management and control of renewable energy sources based smart grid" *International Journal of Emerging Electric Power Systems*, vol. 23, no. 2, 2022, pp. 261-276. <https://doi.org/10.1515/ijeeps-2021-0113>
- [2]. S. G. Malla, P. K. Dadi and J. Dadi, "Wind and photovoltaic based hybrid stand-alone power generation system," 2017 International Conference on Energy, Commu-

- nication, Data Analytics and Soft Computing (ICECDS), Chennai, India, 2017, pp. 3718-3725, doi: 10.1109/ICECDS.2017.8390158.
- [3]. A. Dash, D. P. Bagarty, P. K. Hota, U. R. Muduli, K. A. Hosani and R. K. Behera, "Performance Evaluation of Three-Phase Grid-Tied SPV-DSTATCOM With DC-Offset Compensation Under Dynamic Load Condition," in *IEEE Access*, vol. 9, pp. 161395-161406, 2021, doi: 10.1109/ACCESS.2021.3132549.
- [4]. M. Kumar, "A Review on Control Strategies for Wind Power Generation with DFIG for Smart Microgrid," 2021 International Conference on Control, Automation, Power and Signal Processing (CAPS), Jabalpur, India, 2021, pp. 1-6, doi: 10.1109/CAPS52117.2021.9730683.
- [5]. Malla, Priyanka, Malla, Siva Ganesh and Calay, Rajnish Kaur. "Voltage control of standalone photovoltaic – electrolyzer- fuel cell-battery energy system" *International Journal of Emerging Electric Power Systems*, 2022. <https://doi.org/10.1515/ijeeps-2022-0047>
- [6]. A. Dash, U. R. Muduli, K. A. Jaafari, K. A. Hosani, A. Iqbal and R. K. Behera, "Harmonic Mitigation and DC Offset Rejection for Grid-tied DSTATCOM with CESOGI-WPF Control," 2022 3rd International Conference on Smart Grid and Renewable Energy (SGRE), Doha, Qatar, 2022, pp. 1-6, doi: 10.1109/SGRE53517.2022.9774064
- [7]. J. -M. Won and F. Karray, "Necessity of parametric conditions for monotonic TSK fuzzy systems," 2012 IEEE International Conference on Systems, Man, and Cybernetics (SMC), Seoul, Korea (South), 2012, pp. 2026-2029, doi: 10.1109/ICSMC.2012.6378036.
- [8]. H. Xu, Y. Zhang, Z. Li, R. Zhao and J. Hu, "Reactive Current Constraints and Coordinated Control of DFIG's RSC and GSC During Asymmetric Grid Condition," in *IEEE Access*, vol. 8, pp. 184339-184349, 2020, doi: 10.1109/ACCESS.2020.3029227.
- [9]. K. Sun, W. Yao, J. Fang, X. Ai, J. Wen and S. Cheng, "Impedance Modeling and Stability Analysis of Grid-Connected DFIG-Based Wind Farm With a VSC-HVDC," in *IEEE Journal of Emerging and Selected Topics in Power Electronics*, vol. 8, no. 2, pp. 1375-1390, June 2020, doi: 10.1109/JESTPE.2019.2901747.
- [10]. A. Susperregui, M. I. Martínez, G. Tapia-Otaegui and A. Etxeberria, "Sliding-Mode Control Algorithm for DFIG Synchronization to Unbalanced and Harmonically Distorted Grids," in *IEEE Transactions on Sustainable Energy*, vol. 13, no. 3, pp. 1566-1579, July 2022, doi: 10.1109/TSTE.2022.3166217.
- [11]. B. Hamid, I. Hussain, S. J. Iqbal, B. Singh, S. Das and N. Kumar, "Optimal MPPT and BES Control for Grid-Tied DFIG-Based Wind Energy Conversion System," in *IEEE Transactions on Industry Applications*, vol. 58, no. 6, pp. 7966-7977, Nov.-Dec. 2022, doi: 10.1109/TIA.2022.3202757.
- [12]. S. Bhattacharyya, S. Puchalapalli and B. Singh, "Operation of Grid-Connected PV-Battery-Wind Driven DFIG Based System," in *IEEE Transactions on Industry Applications*, vol. 58, no. 5, pp. 6448-6458, Sept.-Oct. 2022, doi: 10.1109/TIA.2022.3181124.
- [13]. Z. Xie, X. Gao, S. Yang and X. Zhang, "Improved Fractional-order Damping Method for Voltage-controlled DFIG System Under Weak Grid," in *Journal of Modern Power Systems and Clean Energy*, vol. 10, no. 6, pp. 1531-1541, November 2022, doi: 10.35833/MPCE.2020.000843.
- [14]. M. V. Gururaj and N. P. Padhy, "A Cost-Effective Single Architecture to Operate DC Microgrid Interfaced DFIG Wind System During Grid-Connected, Fault, and

- Isolated Conditions," in IEEE Transactions on Industrial Informatics, vol. 16, no. 2, pp. 922-934, Feb. 2020, doi: 10.1109/TII.2019.2926672.
- [15]. C. Wu, P. Cheng, Y. Ye and F. Blaabjerg, "A Unified Power Control Method for Standalone and Grid-Connected DFIG-DC System," in IEEE Transactions on Power Electronics, vol. 35, no. 12, pp. 12663-12667, Dec. 2020, doi: 10.1109/TPEL.2020.2996267.
- [16]. Ouahib Guenounou, Boutaib Dahhou, Ferhat Chabour, TSK fuzzy model with minimal parameters, Applied Soft Computing, Volume 30, 2015, Pages 748-757, <https://doi.org/10.1016/j.asoc.2015.02.017>.
- [17]. Askari, M., Li, J., Samali, B. (2013). A Multi-objective Subtractive FCM Based TSK Fuzzy System with Input Selection, and Its Application to Dynamic Inverse Modeling of MR Dampers. In: Rutkowski, L., Korytkowski, M., Scherer, R., Tadeusiewicz, R., Zadeh, L.A., Zurada, J.M. (eds) Artificial Intelligence and Soft Computing. ICAISC 2013. Lecture Notes in Computer Science, vol 7894. Springer, Berlin, Heidelberg. https://doi.org/10.1007/978-3-642-38658-9_20.
- [18]. L. V. Suresh Kumar & U. Salma (2020) Modular multi-level converter-based DFIG wind power system with MMC-STATCOM, International Journal of Ambient Energy, 41:11, 1243-1251, DOI: 10.1080/01430750.2018.1507938
- [19]. Suratsavadee Koonlaboon KORKUA, Fault-Tolerant Control using Adaptive Time-Frequency Method in Bearing Fault Detection for DFIG Wind Energy System, Walailak Journal: Engineering and Physical Sciences, Vol. 12, Issue. 2, pp. 111-124, 2015.
- [20]. Kandi Bhanu Prakash, "Modeling and Control of UPQC", International Journal of New Technologies in Science and Engineering (IJNTSE), Vol. 8, Issue. 11, pp. 1-5, Nov. 2022.