

TS-Fuzzy Controllers based Novel Control of Grid Connected Fuel Cell Stack System

Mansour Aljohani¹, Siva Ganesh Malla², Mohamed I. Mosaad³

^{1, 3}Electrical & Electronics Engineering Technology Department, Royal Commission Yanbu Colleges & Institutes, Yanbu Industrial City 46452, Saudi Arabia.

²Director, ERG Foundation and CPGC PVT. LTD, Visakhapatnam, Andhra Pradesh, India.

Abstract: Energy storage and utilization-based systems are playing a vital role in power systems. Hydrogen energy based electrical power generation systems are most popular nowadays due to their ability to meet the load demand without any noise, or pollution. Usually, Fuel Cell Stacks (FCSSs) are used to produce electricity from hydrogen and oxygen. Utility grid connected FCs can able to meet load demand quickly as well as improve the power quality at local load bus. Since the FC output is DC, an inverter with an efferent control technique is required to interface the FCs into the AC utility grid. The loads connected at the point of common coupling (PCC) of the FCs to the grid are varying randomly and in terms of their nonlinear and reactive power characteristics. These kinds of loads will affect the power system significantly and result in poor power quality at PCC. Proportional-integral (PI) controllers often cannot operate at their maximal efficiency when the system experiences random fluctuations in addition to the nonlinearities caused by the loads and the power electronic switches used to connect the FC to the grid. This is because these controllers have fixed gains.. One of the most effective solutions to get around these problems associated with using the fixed gain PI controller parameters is to use some adaptive controllers, such as Takagi-Sugeno (TS) Fuzzy controllers. Consequently, a novel control strategy for the inverter is suggested in this paper with the aid of TS-Fuzzy controllers in order to improve the power quality at PCC. Therefore, a novel control strategy for the inverter is suggested in this paper with the aid of TS-Fuzzy controllers in order to improve the power quality at PCC.. Hardware – in the – Loop (HIL) is established with the help of OPAL-RT technologies to enhance the significance of the proposed method. In this study, extensive results are provided and analyzed using HIL under different operating conditions to highlight the effectiveness of the proposed algorithm in mitigating power quality problems.

Corresponding Author: mallasivaganesh@gmail.com

Keywords: *Fuel Cell, Grid Connected System, Hydrogen Storage, TS-Fuzzy, Power Quality, HIL.*

1. Introduction

With the advent of hydrogen fuel cells (FCs), hydrogen is a reliable fuel source, energy carrier, and energy storage for the new era of electrical power generation. FCs have zero carbon emissions, little harm to the environment, a straightforward design, and silent operation [1]. Production of hydrogen during the availability of surplus power from generation is one of the best ideas for energy storage in power system networks. The generated hydrogen can be stored in tanks for further utilization.[2-4]. Usually, aqua-electrolyzers are used to split water into hydrogen and oxygen. A FC can reproduce electricity by using hydrogen and oxygen. There is no release of any toxic gases and noise in during the operation of FCs and produces only water which can again reuse to produce hydrogen and oxygen through an electrolyzer. A single FC is unable to produce the required voltage at its output terminals, hence series of multiple FCs are required to establish FC Stack (FCS) to maintain the rated output voltage. Required power can be obtained by making parallel connections of multiple FCSs. The distribution power supply systems are suffering from peak load demands many times due to a lack of sufficient power generation to meet the load demand. The grid-connected FCS can provide the best solution to the distribution system during peak demand as well as can also improve the power quality at local load bus. In order to integrate FCS into the AC utility grid, an efficient control method-based PWM inverter is required. Local loads at point of common coupling (PCC) demand reactive power support from the utility grid, but it reduces the RMS voltage [2, 5]. Even there will be a chance of sag and swell of voltage in the utility grid due to many conditions. Under these operating conditions, there should be required a device to maintain power quality at PCC by supplying power at a constant voltage level. Hence, it will be an economical solution to use the inverter which required interfacing FCS into the utility grid as a power quality improvement instead of using a separate power custom device. Hence, a novel control is proposed on the inverter in this paper to work as both active power transfer as well as power custom device. The gains of the proportional-integral (PI) controller are tuned at a particular instant, hence unable to produce accurate output instantaneously under random changes in the system due to fixed gains of PI controllers [2]. Therefore, additional adaptive control techniques must be utilized like an Adaptive Neuro-Fuzzy Inference System[6] and adaptive update of the PI controller gains [7]. Hence, Takagi-Sugeno, TS Fuzzy controllers, one of the effective adaptive controllers, will be employed in this paper because they perform better than PI controllers during random fluctuations in the system.

The paper is organized under following sections. Overview and literature review of the grid connected FCS is provided in Section-2. Details regarding design of a TS-Fuzzy controller are given in Section-3. The proposed control scheme is presented in Section-4. Results and discussions based on HIL are carried in Section-5. Conclusion along with references is listed at the end of the paper.

2. Overview of the System

The layout model of utility grid connected FCS is shown in Fig. 1. The FCS is connected to three phase PWM inverter through a boost converter. The boost converter not only regulates the voltage at dc-link (V_{dc}), it can work as maximum power point tracking (MPPT) device for FCS for its best utilization. Hence, it can save the consumption of hydrogen by achieving best utilization. Many authors are already implemented algorithms of MPPT, hence a simple perturbed and observe (P&O) algorithm is implemented in this pa-

per from [2, 5]. Different loads are connected at PCC. The PCC is connected to utility grid through a distribution line. Hence, there will be a drop in voltage at PCC during the operation of heavy load at PCC. The inverter is operated by proposed control mechanism to improve the power quality at PCC. Due to many advantageous of solid oxide fuel cell (SOFC) over other FCs [8-10], SOFC model is considered and modeled in this paper. A 50kW rating of FCS is considered in this paper by connecting five numbers of solid oxide fuel cell (SOFC) with each rating of 10kW in parallel. However, each SOFC is arranged by many FCs in the combination of series and parallel to make the rating of 10kW. Various parameters used in modeling of 10kW SOFC are listed in Table-1. The control of inverter is designed in such a fashion that it allows transferring 50kW of real power as well as compensating reactive power demanded by the local loads connected at PCC for improving power quality. Similar kinds of systems are presented by many scholars recently and listed few of them in below.

Detailed modeling of grid connected SOFC system is presented by authors in [10]. A centralized control scheme for frequency regulation of utility grid is presented by authors in [11] with the help of SOFC. Authors in [12] developed a grid connected Photovoltaic (PV)- FC – ultra capacitor energy storage based hybrid power generation system. A non-linear robust control is designed by authors in [13] for grid connected. In [14], authors proposed a two time-scale separation redesign technique to improve the robustness of inverter for grid connected SOFC. Two coordinated control schemes are implemented by authors in [15] for grid connected SOFC to manage the power flow. A novel functional observer for state estimation of grid connected SOFC is proposed by authors in [16]. In [17], authors proposed a control strategy for a grid integrated PV-FC-Electrolyzer based hybrid power generation system and its benefits. Single stage grid connected FC with the help of a boost inverter is presented by authors in [18]. However, authors in [10-18] are not considered TS-Fuzzy based controller for improving the quality of power at PCC.

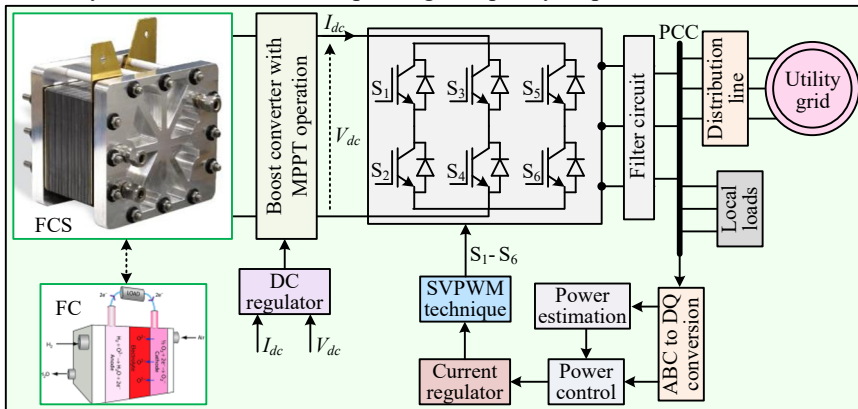

Fig. 1: Grid connected FCS.

Table-1: *Parameters of Fuel Cell*

Absolute temperature(T).	1273.0K.
Faraday's constant(F).	96487C/kmol.
Universal gas constant(R).	8314J/(kmol.K).
Ideal standard potential(E_0).	1.18V.
Number of cells in series in stack(N_0).	325.
Constant, $K_r = N_0/4F$.	$0.842 * 10^{-6}$ kmol/(s.A).
Valve molar constant for hydrogen(K_{H_2}).	$8.43 * 10^{-4}$ (kmol/(s.atm)).

Valve molar constant for water (K_{H_2O}).	$2.81 \cdot 10^{-4}(\text{kmol}/(\text{s} \cdot \text{atm}))$.
Valve molar constant for oxygen (K_{O_2}).	$2.52 \cdot 10^{-3}(\text{kmol}/(\text{s} \cdot \text{atm}))$.
Response time for hydrogen flow (τ_{H_2}).	26.1sec.
Response time for water flow (τ_{H_2O}).	78.3sec.
Response time for oxygen flow (τ_{O_2}).	2.91sec.
Ohmic loss/cell (r).	$32813 \cdot 10^{-8} \Omega$.

3. TS-Fuzzy Controllers

Due to the ability of self tuning process, A TS-Fuzzy controller can deliver superior performance than conventional PI controllers under rapid variation in the system [5]. The operating loads in distribution system are always varying randomly. Hence, proposed control strategy with designed TS-Fuzzy controllers can perform well during all conditions. A detailed implementation of the TS-Fuzzy controller is provided below.

The error signal will be generated by comparing actual value with its reference value. Signals of error (x_i) and change in error (\dot{x}_i) will be treated as input to the TS-Fuzzy controller, as shown in Fig. 2. Two designed membership functions are using with only four rules in TS-Fuzzy controller to produce a desired output, where multiple fuzzy rules are required in Mamdani type fuzzy. Hence, the computational time will be very less in TS-Fuzzy controller which can give fastest accurate response under variations in the system. The mathematical representations of membership functions are expressed by below fundamental equations:

$$\mu_P(x_i) = \begin{cases} 0, & x_i < L_1 \\ \frac{x_i + L_1}{2L_1}, & -L_1 \leq x_i \leq L_1 \\ 1, & x_i > L_1 \end{cases} \text{ and } \mu_N(x_i) = \begin{cases} 1, & x_i < L_1 \\ \frac{-x_i + L_1}{2L_1}, & -L_1 \leq x_i \leq L_1 \\ 0, & x_i > L_1 \end{cases} \quad (1)$$

$$\mu_P(\dot{x}_i) = \begin{cases} 0, & \dot{x}_i < L_2 \\ \frac{\dot{x}_i + L_2}{2L_2}, & -L_2 \leq \dot{x}_i \leq L_2 \\ 1, & \dot{x}_i > L_2 \end{cases} \text{ and } \mu_N(\dot{x}_i) = \begin{cases} 1, & \dot{x}_i < L_2 \\ \frac{-\dot{x}_i + L_2}{2L_2}, & -L_2 \leq \dot{x}_i \leq L_2 \\ 0, & \dot{x}_i > L_2 \end{cases} \quad (2)$$

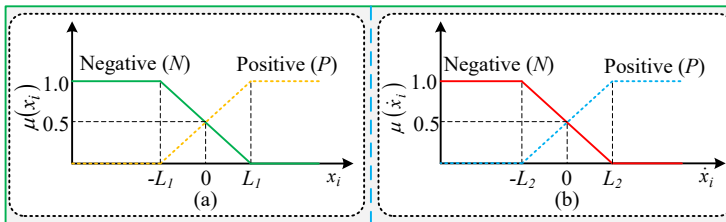

Fig. 2: Membership functions of TS-Fuzzy controller.

The generated output signal is expressed by eq. (3). The list of four rules is given in Table-2. In Table-2, functions Z_{1-4} used to calculate the output of the TS-Fuzzy controller. The sample instant is considered as 'K' and constants a_{1-5} , a_2 , a_3 , a_4 are adjusted by a tuning process which differs from one to another controller. The output function (Y) of a TS-Fuzzy controller is expressed by eq.(3).

$$Y = \frac{\sum_{i=1}^4 Z_i F_i}{\sum_{i=1}^4 Z_i} \quad (3)$$

Where, $F_1 = \text{minimum} \{ \mu_p(\dot{x}_i) \text{ and } \mu_p(x_i) \}$, $F_2 = \text{minimum} \{ \mu_p(x_i) \text{ and } \mu_N(\dot{x}_i) \}$, $F_3 = \text{minimum} \{ \mu_N(x_i) \text{ and } \mu_p(\dot{x}_i) \}$, and $F_4 = \text{minimum} \{ \mu_N(x_i) \text{ and } \mu_N(\dot{x}_i) \}$.

Table-2: Rules of the TS-Fuzzy controller:

Rules	$x_i(k)$	$\dot{x}_i(k)$	Values
1 st Rule	N	N	$Z_1 = a_1 \times x_i(k) + a_2 \times \dot{x}_i(k)$
2 nd Rule	N	P	$Z_2 = a_3 \times Z_1$
3 rd Rule	P	N	$Z_3 = a_4 \times Z_2$
4 th Rule	P	P	$Z_4 = a_5 \times Z_3$

These TS-Fuzzy controllers are used in proposed control method to achieve fast and accurate responses to improve the power quality at PCC under random changes in grid connected FCS.

4. Proposed Control Method

The reactive power demanded by local loads connected at PCC can be compensated by regulating RMS voltage at its reference value through inverter with the help of a proposed control scheme. Further the real power will be transferred from FCS to utility grid at reference targeted power through same inverter by proposed control scheme. Hence, the same inverter can able to work as DSTATCOM as well as transferring the constant real power into utility grid. To achieve fastest and accurate response of the control scheme, designed TS-Fuzzy controllers are adopted in place of conventional PI controllers. These controllers can help to produce quick reference values in the control method during rapid fluctuations in either local loads or utility grid. The required reference real component of current (I_{dref}) flowing through inverter is achieved through TS-Fuzzy controller by comparing real power with reference power of FCS. In the similar way, the reference reactive power component (I_{qref}) is generated from RMS voltage at PCC. The reference currents are then compared with their respective actual currents. A Space Vector Pulse Width Modulation (SVPWM) is used to produce required switching pulses for the inverter to achieve a better synchronization with utility grid. The complete proposed control scheme of the inverter is presented in Fig. 3 with the help of TS-Fuzzy controllers.

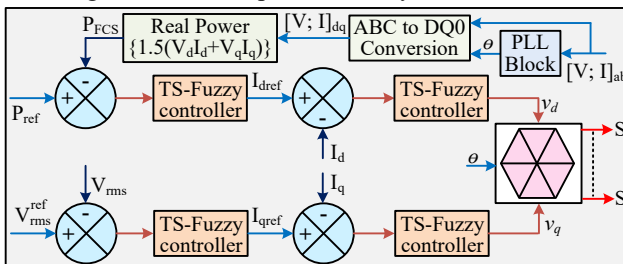

Fig. 3: Proposed control scheme of the inverter.

5. Results and Discussions

The model presented in the Fig. 1 with tentative control schemes are tested by establishing Hardware – in the –Loop (HIL) by using OPAL-RT Module. A simple MPPT controller is applied on boost converter with the help of P&O algorithm. The proposed control of inverter is designed for multiple purposes. The reference power generated by FCS is considered as 50kW. Local reactive loads are connected at PCC and the sag effect is also considered on utility grid. Further the model designed in MATLAB is divided into two parts for the purpose of establishing a HIL setup with the help of OPAL-RT platform. The OPAL-RT modules are capable of providing performance comparable to real-time operations. The OPAL-RT module possesses sufficient capability to effectively solve intricate power system equations in a manner that closely resembles real-time scenarios [2, 3, 8]. Its effectiveness has garnered widespread acceptance among numerous scholars worldwide for the purpose of testing power system components. The RTDS comprises sophisticated computer hardware and extensive software. The hardware architecture features parallel processing and is constructed using modular units, with each unit housing processing and communication modules.

To carry out the HIL setup, numerous academics utilize two OPAL-RT modules based on microcontroller/DSP, along with appropriate data cables for interconnection [2, 3, 8]. Two modules, which have been designed by OPAL-RT technologies, are interconnected via appropriate channels in order to establish a HIL system for evaluating the performance of the proposed model. The schematic representation of the HIL configuration utilizing the OPAL-RT module can be observed in Figure 4. The proposed model presented in Fig. 1 is divided in to two parts, first one consists of plant (FCS, boost converter, inverter, filter, distribution lines, loads, and utility grid) and another unit with proposed control scheme. The plant unit's command signals are transformed into digital signals in order to serve as input for the controller unit (which utilizes a control scheme). The controller unit's output signals are once again transformed into analog signals in order to serve as input signals for the plant unit. Hence it formed a closed loop to test the performance of the proposed controlling techniques to achieve responses similar to real time model. OPAL-RT unit is used for processing of the plant and control scheme is executed in the microcontroller. The complete process of the HIL is performed to analyze the significance of proposed control methods. To examine the output waveforms, the responses of different signals are gathered in a computer using the MATLAB package. The HIL implementation of proposed system is depicted in Fig. 5 to get more clarity. Various responses of the system are presented under different case studies listed in below.

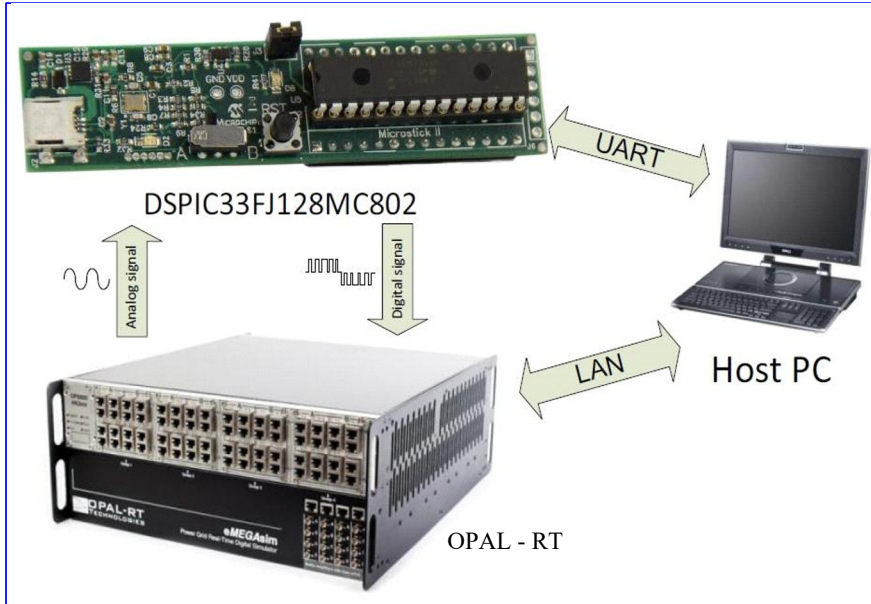

Fig. 4: HIL configuration.

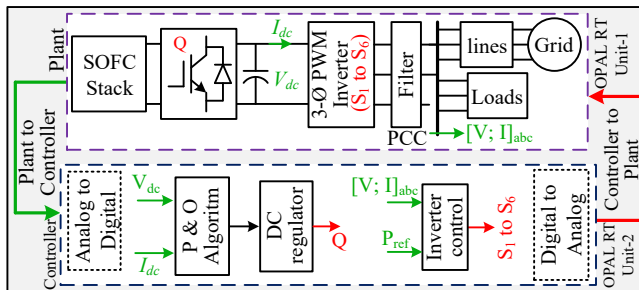

Fig. 5: HIL setup layout of proposed model.

Case-1: Comparison of TS-Fuzzy with PI controller:

The significant of using TS-Fuzzy controllers in proposed control scheme is evaluated in this case by changing 300% of load power at $t=1.0$ sec. The response of line to line RMS voltage with PI and with TS-Fuzzy controllers is depicted in Fig. 6. A stable and less change in voltage is observed with TS-Fuzzy controllers since its ability of quick responses under sudden change in load. Both settling time and dip in voltage are less with TS-Fuzzy controllers as compared with conventional PI controllers. Therefore, further results of the system under various operating conditions are presented by using TS-Fuzzy controllers in proposed control of inverter.

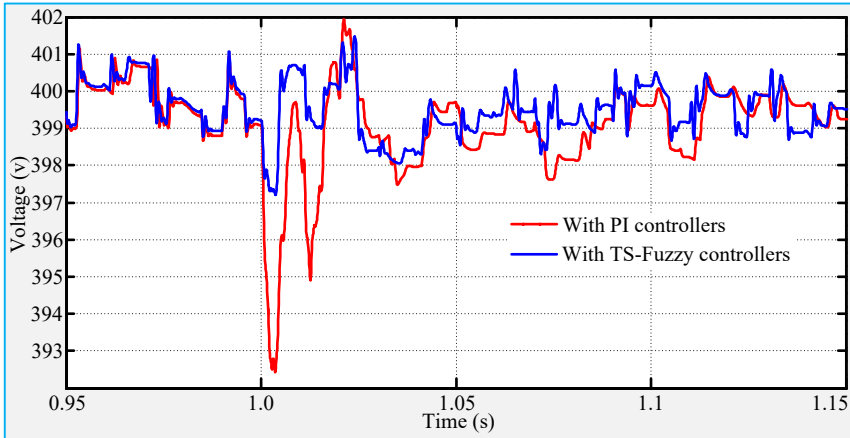
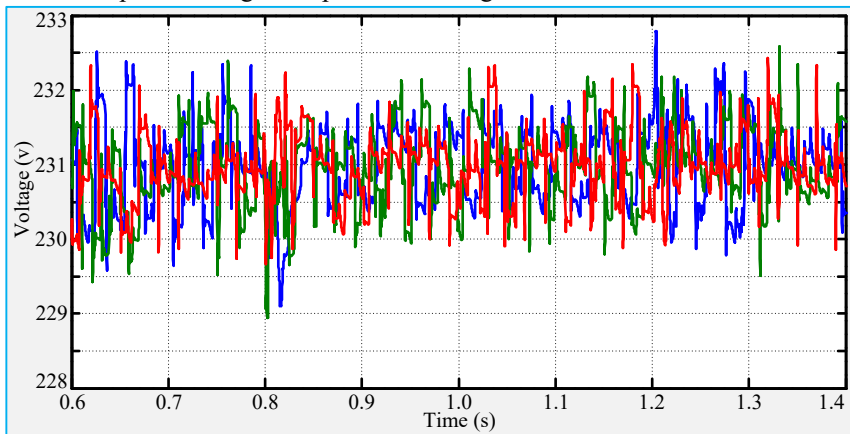

Fig. 6: Line to line voltage under change in load with PI and TS-Fuzzy controllers.

Case-2: Phase voltages during change in load.

A 15kW of load is applied at load bus at $t=0.8$ sec and released at $t=1.2$ sec. During this operation, a small dip and rise are observed in phase voltages at load bus during applying and releasing of the load. However, these changes are very nominal and inverter is regulating phase voltages at its reference value (231V, since line to line is 400V considered). This precious response is obtained by proposed control scheme of the inverter. The precious responses of three phase voltages are presented in Fig. 7.



7: Response of phase voltages during change in load.

Case-3: Operation during reactive power demanded at load bus:

Now, considered that sudden change of load (40kW and 20kVAR) at load bus between $t=2.5$ to 3.0 sec as shown in Fig. 8(a). During this operation, initial load is set at 20kW, Hence total real power demanded by load increases to 60kW after connected new load at $t=2.5$ sec. But the total generation of FCS is kept at 50kW. Hence initially 30kW of power is feeding to grid by FCS and the grid needs to provide 10kW more to the load after $t=2.5$ sec. The inverter is compensating the reactive power by proposed control method when load demanding more reactive power. The real and reactive power of FCS through inverter is depicted in Fig. 8(b). Therefore, grid no needs to supply any reactive power but the deficiency of active power (i.e., 10kW) should be managed by grid. Corresponding powers (P; Q) are provided in Fig. 8(c). The positive sign of grid power denoted receiving

from FCS, and negative represents supply from grid to load. This is achieved by regulating RMS voltage at load bus by proposed control method. The line to line RMS voltages at load bus are depicted in Fig. 8(d) which stabilized at its reference value (i.e., 400V). However, initially 30kW is taken by the grid from FCS and grid is supplying 10kW after load increases to 60kW between $t=2.5$ to 3.0 sec. Respective currents of grid are provided in Fig. 9 for more clarity on the operation of proposed control method. Currents between $t=2.5$ to 3.0 secs represents the supplying power to load bus from grid.

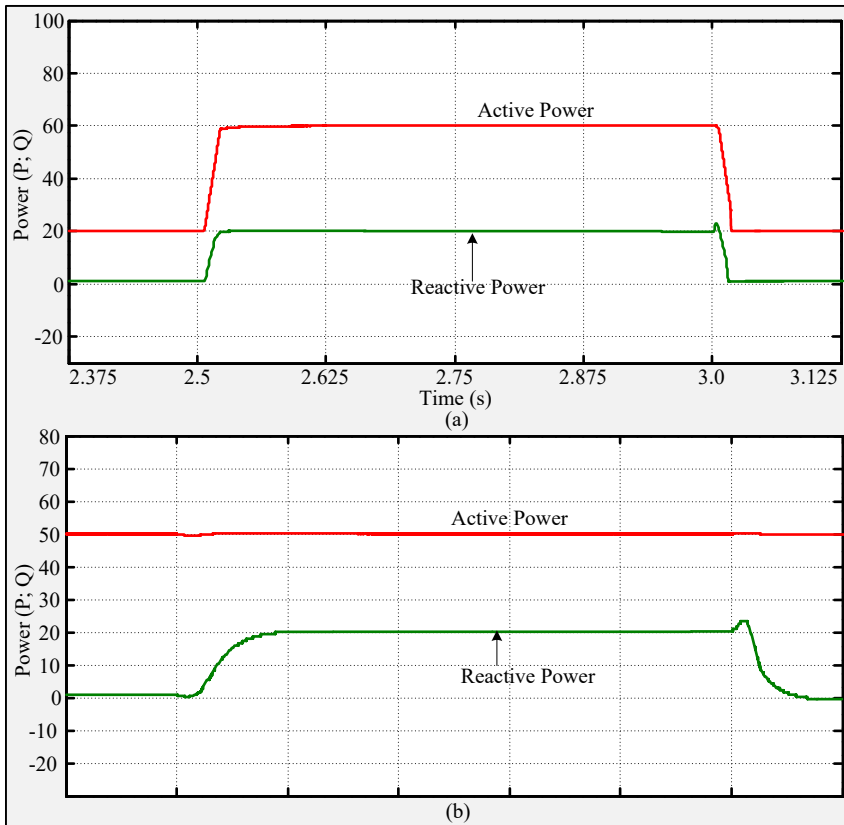

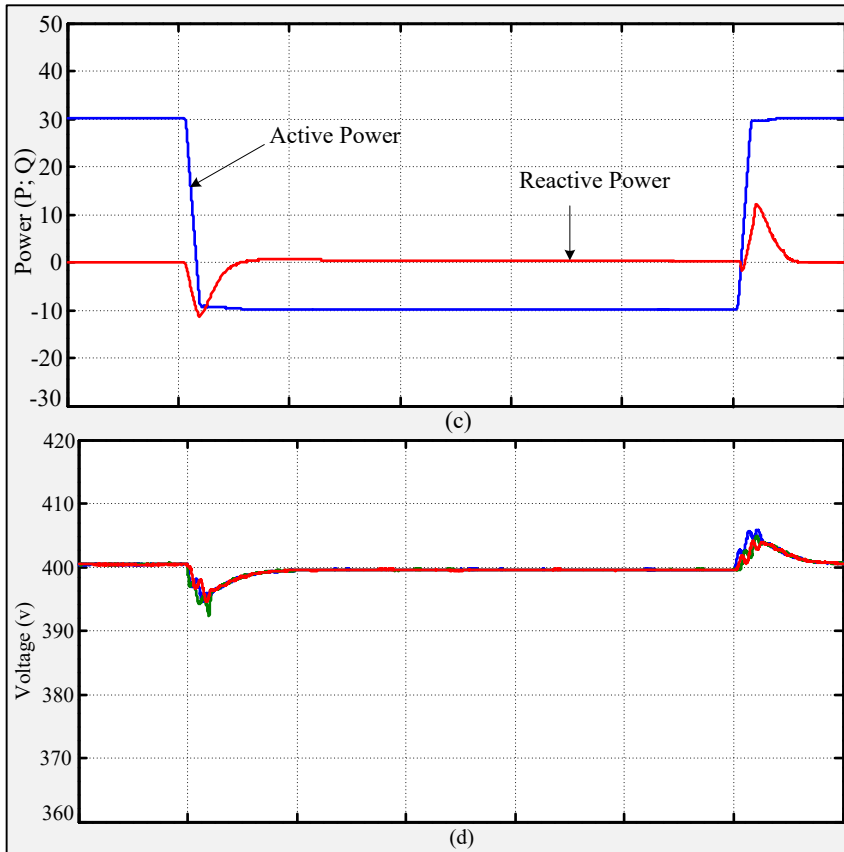

Fig. 8: Responses of (a): powers at load bus; (b) powers through inverter-FCS, (c): powers of grid, (d) RMS line to line voltages at load bus.

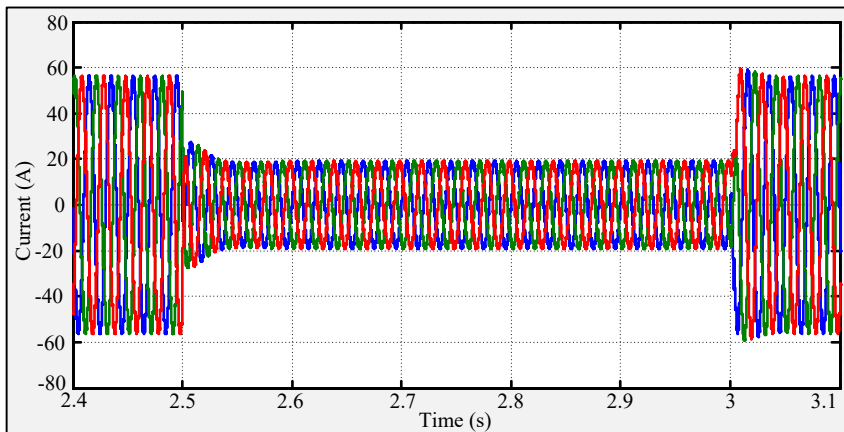

Fig. 9: Grid currents.

Case-4: Response of proposed method during sag on grid:

Considered sag occurred on grid voltages during $t=1.5$ to 1.7 sec as shown in Fig. 10(a). Generally voltages at load bus will be reduced during the sag. However, the pro-

posed control method is maintaining voltages at load bus. Hence, stable and constant voltages are achieved at load bus as shown in Fig. 10(b).

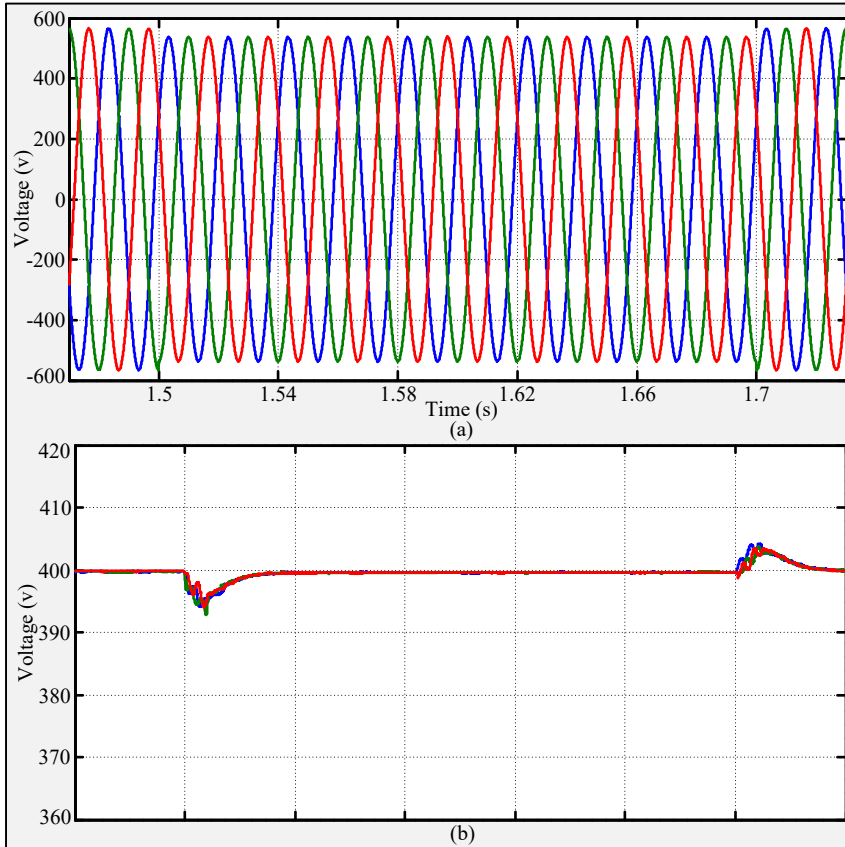

Fig. 10: (a) Grid voltages during sag, (b) line to line RMS voltage at load bus.

6. Conclusion

TS-Fuzzy controllers based a novel control scheme of the inverter is proposed in this paper for grid connected FCS to improve power quality at load bus. A fast and stable response is achieved in the system by using TS-Fuzzy controllers. The inverter is able to supply real power from FCS to grid at its reference as well as can compensate reactive power demanded by the loads. Hence, the peak load can be reduced on the grid as well as grid is no need to supply any reactive power to local loads. Moreover, the voltage support to loads also achieved through proposed method during voltage sag occurred on grid. Therefore, the proposed method is improving the quality of the power at load bus. Results are presented through HIL with the help of OPAL-RT modules to enhance the proposed model. Hence, realistic responses are obtained to examine under various operating conditions.

References

- [1]. Haitham S. Ramadan, Sanjeevikumar Padmanaban, Mohamed I. Mosaad, Metaheuristic-based Near-Optimal Fractional Order PI Controller for On-grid Fuel Cell Dynamic Performance Enhancement, *Electric Power Systems Research*, Volume 208, 2022, 107897, ISSN 0378-7796, <https://doi.org/10.1016/j.epsr.2022.107897>.

- [2]. Malla, Priyanka, Malla, Siva Ganesh and Calay, Rajnish Kaur. "Voltage control of standalone photovoltaic – electrolyzer- fuel cell-battery energy system" *International Journal of Emerging Electric Power Systems*, 2022. <https://doi.org/10.1515/ijeeps-2022-0047>.
- [3]. P. A. Lindahl, S. R. Shaw and S. B. Leeb, "Fuel Cell Stack Emulation for Cell and Hardware-in-the-Loop Testing," in *IEEE Transactions on Instrumentation and Measurement*, vol. 67, no. 9, pp. 2143-2152, Sept. 2018, doi: 10.1109/TIM.2018.2814070.
- [4]. J. Bauman and M. Kazerani, "A Comparative Study of Fuel-Cell–Battery, Fuel-Cell–Ultracapacitor, and Fuel-Cell–Battery–Ultracapacitor Vehicles," in *IEEE Transactions on Vehicular Technology*, vol. 57, no. 2, pp. 760-769, March 2008, doi: 10.1109/TVT.2007.906379.
- [5]. Siva Ganesh Malla, t. al., "Coordinated power management and control of renewable energy sources based smart grid" *International Journal of Emerging Electric Power Systems*, vol. 23, no. 2, 2022, pp. 261-276. <https://doi.org/10.1515/ijeeps-2021-0113>.
- [6]. Chehaidia, Seif Eddine, Hakima Cherif, MusferAlraddadi, Mohamed Ibrahim Mosaad, and Abdelaziz Mahmoud Bouchelaghem. 2022. "Experimental Diagnosis of Broken Rotor Bar Faults in Induction Motors at Low Slip via Hilbert Envelope and Optimized Subtractive Clustering Adaptive Neuro-Fuzzy Inference System" *Energies* 15, no. 18: 6746. <https://doi.org/10.3390/en15186746>
- [7]. Banakhr, F.A., Mosaad, M.I. High performance adaptive maximum power point tracking technique for off-grid photovoltaic systems. *Scientific Report* 11, 20400 (2021). <https://doi.org/10.1038/s41598-021-99949-8>
- [8]. C. N. Bhende, S. Mishra and S. G. Malla, "Permanent Magnet Synchronous Generator-Based Standalone Wind Energy Supply System," in *IEEE Transactions on Sustainable Energy*, vol. 2, no. 4, pp. 361-373, Oct. 2011, doi: 10.1109/TSTE.2011.2159253.
- [9]. W. Du, J. Cao, H. F. Wang, Y. X. Xiao and S. Q. Bu, "Modelling a grid-connected SOFC power plant into a multi-machine power system," *IET Conference on Renewable Power Generation (RPG 2011)*, Edinburgh, 2011, pp. 1-6, doi: 10.1049/cp.2011.0208.
- [10]. M. B. de O. e Silva, J. F. Fardin, L. F. Encarnação and R. Fiorotti, "Modeling and grid connection of a solid oxide fuel cell (SOFC) based on P-Q theory for stationary loads," *2015 IEEE PES Innovative Smart Grid Technologies Latin America (ISGT LATAM)*, Montevideo, Uruguay, 2015, pp. 541-545, doi: 10.1109/ISGT-LA.2015.7381212.
- [11]. A. Estebarsari, S. Vogel, R. Melloni, M. Stevic, E. F. Bompard and A. Monti, "Frequency Control of Low Inertia Power Grids With Fuel Cell Systems in Distribution Networks," in *IEEE Access*, vol. 10, pp. 71530-71544, 2022, doi: 10.1109/ACCESS.2022.3187099.
- [12]. S. Padmanaban, N. Priyadarshi, M. S. Bhaskar, J. B. Holm-Nielsen, E. Hossain and F. Azam, "A Hybrid Photovoltaic-Fuel Cell for Grid Integration With Jaya-Based Maximum Power Point Tracking: Experimental Performance Evaluation," in *IEEE Access*, vol. 7, pp. 82978-82990, 2019, doi: 10.1109/ACCESS.2019.2924264.
- [13]. M. R. Mahmud and H. R. Pota, "Robust Nonlinear Controller Design for DC–AC Converter in Grid-Connected Fuel Cell System," in *IEEE Journal of Emerging and Selected Topics in Industrial Electronics*, vol. 3, no. 2, pp. 342-351, April 2022, doi: 10.1109/JESTIE.2021.3088394.
- [14]. M. E. Raoufat, A. Khayatian and A. Mojallal, "Performance Recovery of Voltage Source Converters With Application to Grid-Connected Fuel Cell DGs," in *IEEE Transactions on Smart Grid*, vol. 9, no. 2, pp. 1197-1204, March 2018, doi: 10.1109/TSG.2016.2580945.
- [15]. L. Sun, G. Wu, Y. Xue, J. Shen, D. Li and K. Y. Lee, "Coordinated Control Strategies for Fuel Cell Power Plant in a Microgrid," in *IEEE Transactions on Energy Conversion*, vol. 33, no. 1, pp. 1-9, March 2018, doi: 10.1109/TEC.2017.2729881.
- [16]. K. Emami, H. Ariakia and T. Fernando, "A Functional Observer Based Dynamic State Estimation Technique for Grid Connected Solid Oxide Fuel Cells," in *IEEE Transactions on Energy Conversion*, vol. 33, no. 1, pp. 96-105, March 2018, doi: 10.1109/TEC.2017.2739153.
- [17]. S. S. Kumar, N. Mukundan C. M. and J. P., "Modified LMS Control for a Grid Interactive PV–Fuel Cell–Electrolyzer Hybrid System With Power Dispatch to the Grid," in *IEEE Transactions on Industry Applications*, vol. 58, no. 6, pp. 7907-7918, Nov.-Dec. 2022, doi: 10.1109/TIA.2022.3200926.
- [18]. J. Kan, S. Xie, Y. Wu, Y. Tang, Z. Yao and R. Chen, "Single-Stage and Boost-Voltage Grid-Connected Inverter for Fuel-Cell Generation System," in *IEEE Transactions on Industrial Electronics*, vol. 62, no. 9, pp. 5480-5490, Sept. 2015, doi: 10.1109/TIE.2015.2416339.