

Increasing the efficiency of a mining and processing enterprise based on an automated system for monitoring the lower position of the crushing cone

*Maksim Taranenko*¹, *Denis Ermolaev*¹, *Irina Minakova*², *Tatiana Bukreeva*^{2*}, and *Marina Parkhomchuk*²

¹Gubkin Branch of National University of Science and Technology MISiS, Komsomolskaya str. 16, Gubkin, Belgorod region, 309186, Russia

²Southwest State University, 50 let Oktyabrya str. 94, Kursk, 305040, Russia

Abstract. The article presents the automated control system developed by the authors for monitoring the lower position of the crushing cone in the KKD-1500/180-GVP (gyratory-cone crusher with hydraulic upper suspension) based on a non-contact inductive position sensor. The proposed system allows timely informing personnel about the non-regulatory lowering of the crushing cone to the lower level with prompt adoption of measures to eliminate or repair the crusher hydraulic unit, as well as constantly maintain the optimal mode of ore crushing with specified grain size. Implementation of this automated control system for monitoring the lower position of the crushing cone will reduce concentrate losses at the enterprise and increase production efficiency by minimizing specific energy consumption.

1 Introduction

Gyratory-cone crushers are the most common machines used at all stages of rock fragmentation. This type of machines was invented in the second half of the 19th century, and replaced previously used jaw crushers, especially in large enrichment plants. Currently, gyratory-cone crushers continue to successfully compete with crushing machines that use other principles of material breakage. Gyratory-cone crushers are used to break a wide variety of rocks. With the exception of very viscous materials with a high clay content (such as alumina) or very hard ones (such as ferrochrome), the fragmentation function of this type of machines is very efficient. In gyratory-cone crushers, the material is crushed between two cone-shaped surfaces, one of which performs a swinging circular (gyratory) motion, as a result the surfaces of the cones either approach or diverge. The first gyratory-cone crusher was manufactured by Allis-Chalmers (USA) in 1880 upon the project of Gates.

The crushing process in gyratory-cone crushers, unlike jaw crushers, carries out continuously. The advantage of this type of crushers is zero idling. Gyratory-cone crushers

* Corresponding author: tnbinchina@yandex.ru

are continuous crushing units capable of operating under debris. At the same time, the main disadvantage of gyratory cone crusher is high energy consumption. Thus, the reduction of energy consumption of gyratory-cone crusher has become one of the main tasks of the design improvement of this type of machine.

Thus, the requirements for increasing the efficiency of technological processes and creating competitive, efficient production determine the need to improve crushing and grinding equipment, which ensures a significant reduction in energy costs for ore preparation.

Lebedinsky GOK has installed 4 similar gyratory-cone crushers KKD-1500/180-GVP manufactured by the Ural Heavy Engineering Plant.

The KKD-1500/180-GVP crushers are designed for primary coarse breaking of ferruginous quartzite from a mining quarry with a temporary compressive strength of up to 250 MPa (2500 kgf/cm²), with a moisture content of up to 4% [1, 2, 3].

The KKD-1500/180-GVP gyratory-cone crusher is made according to the classical design (Figure 1).

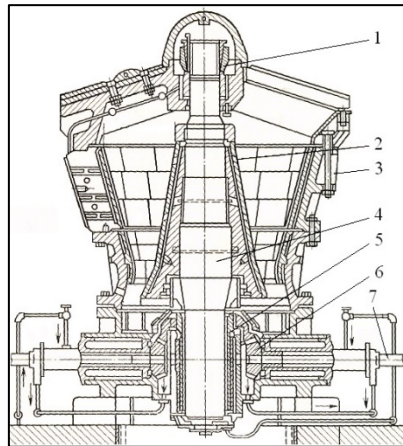

Fig. 1. KKD gyratory-cone crusher for coarse breaking: 1 – hydraulic top suspension; 2 – movable crushing cone; 3 – fixed lined bowl; 4 – main shaft; 5 – eccentric; 6 – drive bevel gear; 7 – drive shaft.

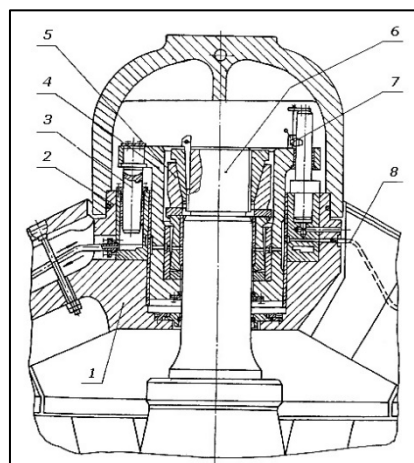

Fig. 2. Hydraulic top suspension: 1 – spider; 2 – hydraulic unit frame; 3 – piston; 4 – cylinder; 5 – upper tapped hinge; 6 – crushing cone; 7 – crushing cone lift indicator; 8 – lubricant supply.

The KKD-1500/180-GVP gyratory-cone crusher is designed with a hydraulic top suspension, which serves as a mechanism for regulating the crusher opening. The structural diagram of the hydraulic top suspension of the KKD-1500/180-GVP gyratory-cone crusher is shown in Figure 2.

As the armor wears out during crusher operation, the crusher opening increases. In order to provide the required particle-size of the product, it is necessary to maintain a size of the crusher opening [4, 5, 6].

The crusher opening adjustment is made by vertical movement (raising or lowering) of the crushing cone. Model of the stroke of the crushing cone is the following:

- Installation stroke 0-100 mm (cone installation);
- Forward stroke 100-300 mm (wear compensation with armor);
- Emergency lower limit of the height position of the cone – 20 mm [7].

The problem of adjusting the optimal height of the cone has been covered in the works of Russian and foreign scientists. Thus, they have described in details domestic and foreign designs of gyratory-cone crushers, considered methods for calculating their design and technological parameters, introduced the results of experimental studies of technological and mechanical operating modes, and presented the automation framework for control of crushing machines and crushing processes [1, 2, 3].

In addition, the engineering designers have substantiated the importance of adjusting the cone's position of a gyratory-cone crusher for effective breaking [4, 5, 6], and proposed a method for predicting crusher performance and product distribution by particle size [4], and a method for optimizing the geometry of the working chamber of a gyratory-cone crusher using many constraints [5]. Studies have been carried out on the influence of the crusher slot size on the total product size distribution [6]; the efficiency of cone crusher operating modes and its productivity in order to design the working chamber geometry [7].

The study has introduced the approach to achieve optimal control of gyratory-cone crushers (maintaining an intended size of the crusher opening) using sensors for direct measurement of lining wear [8]. The authors have developed the gyratory-cone crusher control system based on a non-contact granulometer of the output product using a hydraulic cylinder for monitoring the cone's vertical movement [9].

The research literature examines the main scientific and technological achievements in mechanical engineering. It has provided a basis for developing a modernized crushing equipment to solve the problem of extending the crusher's service life, simplifying its maintenance and repair, achieving a good economic effect and improving the quality of the finished product [10].

The object of the research is gyratory-cone crushers with a hydraulic top suspension (KKD-1500/180-GVP).

The purpose of the work is to develop an automated control system for monitoring the lower position of the cone in the KKD-1500/180-GVP crusher, which allows increasing production efficiency by reducing specific energy consumption.

2 Materials and methods

The research works of the following authors cover the various aspects of increasing the efficiency in the mining industry: Brika Z., Gamache M., Dimitrakopoulos R. [11], Sadrossadat E., Basarir H., Karrech A., Elchalakani, M. [12], Otieno F., Shukla S. K. [13], Mohtasham M., Mirzaei-Nasirabad H., Askari-Nasab H., Alizadeh B. [14], Perotti D. A., Gitirana G. F. N., Mendes T. A., Fredlund M. D. [15], Manzoor S., Gustafson A., Johansson D., Schunnesson H. [16], Barakos G. [17], Stratakis A., Petrakis E., Katzagianakis N., Alevizos G. [18], Phillips N. [19], Chen T., Li Y., Habib K. M., Mitri H. S. [20].

Currently, researchers pay attention to the energy saving issues in mining industries [21, 22, 23, 24, 25, 26, 27]. The theoretical framework of the study is based on the domestic and foreign publications for a topic of increasing the efficiency of iron ore raw materials production by ore mining enterprises.

The methodology and research methods are comprehensive. They involve experimental and theoretical studies of the crushing process in gyratory-cone crushers and conduct laboratory, bench and operational tests. The research is based on system analysis, modelling and engineering analysis. For conducting experimental studies, the authors have used modern equipment, instrumentation and statistical processing of results.

3 Results and discussion

The automated system for maintaining the height position of the crushing cone of the KKD-1500/180-GVP crusher is designed to perform the following functions:

- continuous monitoring of the height position of the crushing cone;
- automatic maintenance of the given current position of the crushing cone (after installing the required discharge slot);
- regulating the current position of the crushing cone in order to compensate for the increase in the crusher opening due to armor wear [8, 9, 10].

The system is based on the installation of an ultrasonic non-contact sensor under the spider cap; the sensor location is shown in Figure 3 and Figure 4. The sensor is installed on a shaft; its radiation is reflected from the upper end of the cylinder, which is kinematically rigidly connected to the crushing cone. Based on the reflected beam, the distance from the sensor to the cylinder is determined using secondary equipment installed in the control cabinet. Information about the height position of the crushing cone is displayed on the digital display of the graphic indicator on the control box of the hydraulic unit, and can be transmitted via the interface output of the indicator to the automated process control system of the crushing place.

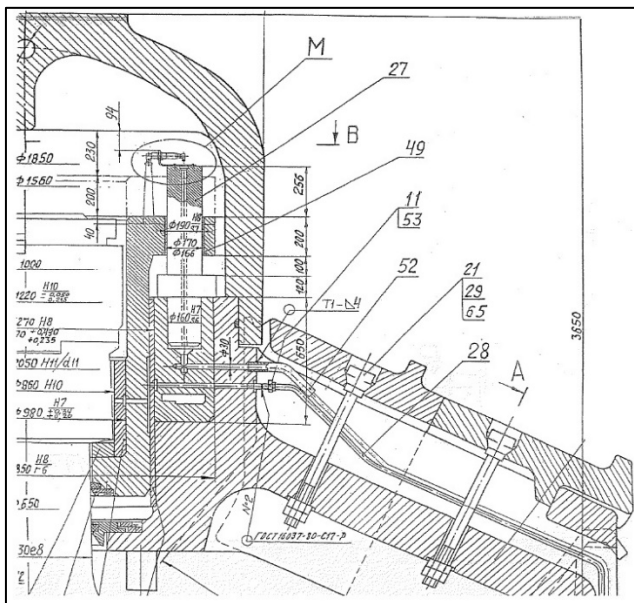

Fig. 3. Spider of the KKD gyratory-cone crusher.

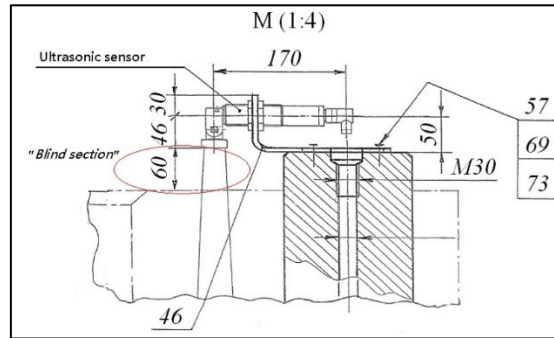

Fig. 4. Ultrasonic sensor location on the KKD gyratory-cone crusher.

The automated system for maintaining the height position of the cone (ASM-HPC) is not used at Lebedinsky GOK JSC for the following reasons:

- in the hydraulic system of the upper suspension (due to the long stay of the spider on an uncovered repair site), it is impossible to ensure cleanliness of the oil; (fine dust, pieces of ore, etc. gathers), which causes leaky closure of hydraulic elements (valves, switches, etc.), and oil leakage, leading to repeated lifting of the cone;
- there is no direct control of the cone's lower limit in the ASM-HPC system (this zone is outside the sensor's visibility). The required measurement range is 60 mm + 300 mm = 360 mm (in fact, the limit is 300 mm, where 60 mm is the height of the initial gap between the sensor and the cylinder in the upper position (Figure 4), 300 mm is the forward stroke of the cylinder);
- the ultrasonic sensor installed by the manufacturer has a 'blind' section of 0...60 mm from the sensor (Figure 4), thereby the limit of the forward stroke of the suspension reduces from 300 mm to 240 mm, which is not enough. Thus, moving from the sensor by 250 mm makes its work unstable (readings change);
- the proposed design of the sensor-mounting bracket does not provide rigidity of the structure, it does not exclude shaking during operation under load, which distorts the readings of the device;
- when lifting the cylinder (the exit along the piston is more than 300 mm), the ultrasonic sensor was damaged, i.e. the bracket design does not protect the sensor from mechanical actions;
- the ultrasonic position sensor does not work at temperature below -15 °C;
- when setting a given position, 'unloading inhibit' is activated, it negatively affects the rhythm of unloading dump cars of specialized electric trains at the receiving bunker;
- the digital display does not reflect the crusher opening, but the distance from the head of the ultrasonic position sensor to the upper end of the suspension cup;
- high price of an ultrasonic position sensor;
- maintenance or replacement of the ultrasonic position sensor requires a long downtime of the crusher (from 12 to 20 hours).

Thus, there is no limit control for the cone's lower level of the KKD-1500/180-GVP crushers.

The opening is adjusted manually by crusher operator:

- cone lift – (turning on/off the hydraulic unit pump from the local control console);
- lowering the cone – (opening/closing the hydraulic unit oil system valve).

Adjusting the crushing cone to the lower level (maximal gap) leads to the release of coarse-grained crushed ore, it causes the clogging of the cross-piece of the KKD crushers,

conveyor transfer units, feeders, leaving the enrichment shops without ore load; with subsequent shutdowns of mills and crushers, long unscheduled downtime for cleaning transfer units, loading trolleys and crosses.

The latter proves the importance of developing a system for monitoring the lower position of the crusher KKD-1500/180-GVP [8, 9, 10].

Analysis of the crusher operation showed:

1. control of the cone position (in the position when the cylinder dropped onto the boss) is ineffective and useless, it does not allow personnel react instantly and prevent coarse-grained crushed ore from entering the enrichment shops and reduce the clogging of transfer units;
2. the lower position of the cone, which maintains the standard size of the output product, is the level of +50 mm from the shafts' bosses.

We are considering the possibility of implementing a control system for the cone's lower level using a non-contact inductive distance sensor. It is assumed that the sensor will be placed on the spider (under the cap) of the crusher, and it will measure the distance between the spider and the cylinder. The sensor is proposed to control the cone's lower position at points +50 mm or less from the shafts' bosses. The sensor will be connected by a paired cable; the cable will be laid through a hole in a shaft and a cable channel in the spider.

The inductive sensor IFM Electronic ID0013 serves as a non-contact distance sensor. Its operating principle is based on changing the parameters of the inductor's magnetic field, which affects the metal objects.

The overall dimensions of the sensor allow it to be placed on the spider between the shaft and the piston: its height is less than the height of the shafts' bosses. Thus, the sensor is protected from damage (in the position when the cone is lowering onto the shafts' bosses).

The operating principle of the proposed control system for the cone's lower level of the crusher KKD-1500/180-GVP JSC Lebedinsky GOK based on a non-contact inductive distance sensor is shown in Figure 5.

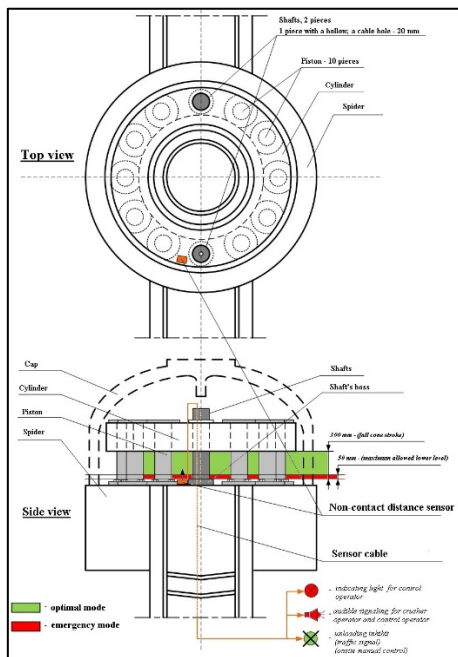

Fig. 5. Operating principle of the cone lower position control system.

When the sensor is triggered (the position of the crushing cone at the control point), the following occurs:

- light and audible signaling for control panel operator;
- audible signaling (for crusher operator);
- activating ‘unloading inhibit’ for dump cars of specialized electric trains (traffic signal), (onsite manual control by crusher operator).

The implementation of control systems for monitoring the lower position of the crushing cone will reduce the concentrate losses and minimize energy consumption due to:

- minimizing the ore drawing of coarse-grained particle size;
- reducing clogging of transfer units, mill feeders, crushers’ crosses;
- reducing the number of unscheduled equipment starts after reduction of blockages;
- reducing the mills operating time in enrichment shops without load, i.e. mills operation with an increase in specific electricity standards.

4 Conclusion

A gyratory-cone crusher breaks down hard rocks by compressing and crushing them into small pieces of the required size. Getting into the space between the movable conical surface and the cone-shaped stationary bowl, rocks are crushed. Such design is used for grinding hard metallic and non-metallic ore rocks. Nowadays, many mining and processing enterprises use a primary gyratory-cone crusher as the main machine. At the same time, there is no control of the cone’s lower limit in the KKD-1500/180-GVP crushers. Adjusting the crusher opening is carried out by crusher operator in manual mode. It often leads to the lowering of the crushing cone to the lower level and to the release of coarse-grained crushed ore, and clogging of cross-piece of the crushers.

The control system for the cone’s lower level of the KKD-1500/180-GVP crusher based on a non-contact inductive position sensor will allow maintaining the crushing operating mode and preventing the release of coarse-grained crushed ore.

The proposed control system for the cone’s lower level will ensure efficient operation of the KKD-1500/180-GVP crushers, reduce losses of concentrate from the processing plant, and increase production efficiency by reducing specific energy consumption.

The publication was carried out within the framework of the State Task of the Ministry of Science and Higher Education of the Russian Federation (topic No. 1.13.20 F ‘Conceptual foundations for ensuring economic security of the Russian Federation in the conditions of digitalization: contours of spatial transformations’).

References

1. Yu.A. Muizemnek, G.A. Kalyunov, Ye.V. Kochetov, Cone crushers, Mashinostroenie Publ. (1970)
2. V.A. Bauman, B.V. Klushantsev, V.D. Martynov, Mechanical equipment for enterprises of building materials, products and structures, Mashinostroenie Publ. (1981)
3. B.V. Klushantsev, A.I. Kosarev, I. Yu.A. Muizemnek, Crushers. Design, calculations, operating features, Mashinostroenie Publ. (1990)
4. C. Evertsson, Miner. Eng. **11(3)**, 215-231 (1998)
5. K.T. Atta, A. Johansson, T. Gustafsson, Miner. Eng. **56**, 81-90 (2014)
6. P. Kivikytö-Reponen, S. Ala-Kleme, J. Hellman, J. Liimatainen, S.-P. Hannula, Wear **267(1-4)**, 568-575 (2009)

7. D. Gang, H. Dongming, F. Xiumin, *Int. J. Miner. Process.* **93(2)**, 204-208 (2009)
8. M. Moshghbar, R.A. Bearman, R. Parkin, *Miner. Eng.* **8(4-5)**, 367-376 (1995)
9. Yu.N. Chesnokov, V.G. Lisienko, A.V. Lapteva, *System for regulating the granulometric composition of ore materials at the outlet of a cone crusher with a hydraulic cylinder*, in Proceedings of the VIII All-Russian scientific and practical conference of students, graduate students and young scientists, 16-17 May 2019, Yekaterinburg, Russia (2019)
10. I.O. Egorochkina, D.Yu. Kucherenko, V.H. Sogomonov, A.I. Kiryukhin, *Eng. J. of Don* **4** (2017)
11. Z. Brika, M. Gamache, R. Dimitrakopoulos, *Int. J. Min. Reclam. Env.* **37(5)**, 355-374 (2023)
12. E. Sadrossadat, H. Basarir, A. Karrech, M. Elchalakani, *Int. J. Min. Reclam. Env.* **37(2)**, 110-126 (2023)
13. F. Otieno, S. K. Shukla, *Int. J. Min. Reclam. Env.* **37(2)**, 127-147 (2023)
14. M. Mohtasham, H. Mirzaei-Nasirabad, H. Askari-Nasab, B. Alizadeh, *Int. J. Min. Reclam. Env.* **36(7)**, 461-491 (2022)
15. D. A. Perotti, G. F. N. Gitirana, T. A. Mendes, M. D. Fredlund, *Int. J. Min. Reclam. Env.* **36(7)**, 492-511 (2022)
16. S. Manzoor, A. Gustafson, D. Johansson, H. Schunnesson, *Int. J. Min. Reclam. Env.* **36(3)**, 159-173 (2022)
17. G. Barakos, *Int. J. Min. Reclam. Env.* **36(9)**, 605-606 (2022)
18. A. Stratakis, E. Petrakis, N. Katzagiannakis, G. Alevizos, *Appl. Earth Sci.* **129(4)**, 217-230 (2020)
19. N. Phillips, *Economic geology, principles and practice: metals, minerals, coal and hydrocarbons – an introduction to formation and sustainable exploitation of mineral deposits*, 2nd ed.: by W.L. Pohl, Stuttgart, Schweizerbart Science Publ. (2020)
20. T. Chen, Y. Li, K. M. Habib, H. S. Mitri, *CIM J.* **15(1)**, 33-44 (2024)
21. M. Bahadori, S. M. Mousavi, *Appl. Earth Sci.* **131(4)**, 193-205 (2022)
22. T. Fallah, J. Belghaieb, N. Hajji, *Energy Sources, Part A: Recovery, Util., Environ. Eff.* **45(4)**, 9827-9833 (2023)
23. S. Ding, F. Pan, S. Zhou, X. Bu, M. Alheshibri, *Energy Sources, Part A: Recovery, Util., Environ. Eff.* **45(4)**, 10523-10536 (2023)
24. P. Deng, Y. Guo, J. Zhou, L. Wang, X. Zhou, F. Xu, *Energy Sources, Part A: Recovery, Util., Environ. Eff.* **45(4)**, 11060-11081 (2023)
25. S. Zhu, J. Cheng, Z. Wang, M. Borowski, *Energy Sources, Part A: Recovery, Util., Environ. Eff.* **45(4)**, 11278-11295 (2023)
26. C. Liu, X. Zheng, N. M. Shahani, Z. Li, *Energy Sources, Part A: Recovery, Util., Environ. Eff.* **45(4)**, 12329-12342 (2023)
27. M. Liu, J. Wu, Z. Lang, X. Meng, *Energy Sources, Part B: Econ. Plan. Policy* **18(1)** (2023)