

Comparative analysis of the cost of foundations of various types

Nikolai Seregin^{1*}

¹National Research Moscow State University of Civil Engineering (NRU MGSU), 26, Yaroslavskoe shosse, Moscow, 129337, Russia

Abstract. The article discusses two methods of calculating bases. The loads of the impact of the foundation on the base are analyzed. The task of calculating the foundation is set. The order of accounting of the foundation depending on the type of foundation is considered. The types of foundations are described. The structural and geometric parameters of the foundations are given. The manufacturing technologies of drilling concrete piles and drilling-mixing cement-ground piles are considered in detail. The results of the study of various types of foundations are presented. A comparative comprehensive analysis of the cost of construction of various types of foundations is given. Conclusions on the choice of foundations depending on the properties of the foundations are formulated.

1 Introduction

The reliability of foundations determines the strength and stability of buildings and structures. Loads from buildings and structures are perceived by the soles of foundations, which rest on bases that are layers of soil. [1].

The basic principles of the design of foundations are: the design of foundations according to the limiting conditions; consideration of the joint work of the foundation, foundations and aboveground supporting structures; a comprehensive assessment of the nature of the work of the foundation soils and the choice of the type of foundations as a result of joint consideration [2]:

- engineering-geological and hydrogeological conditions of the construction site;
- sensitivity of structures to uneven precipitation;
- for the method of performing earthworks the construction of foundations, communications and underground parts of structures.

The design task is complex and multifaceted, so it is recommended to consider several options for foundations and choose the most rational solution based on a technical and economic comparison. Solutions are usually chosen when designing the most loaded, typical for the construction of foundations. According to the selected option, the foundation of the remaining foundations is calculated. Calculations should confirm that precipitation and its irregularities are less than the permissible values for the projected structure, the foundation soils and the foundation are stable, the foundation has the required strength [3].

Two calculation methods are used in the design of the foundations.

* Corresponding author: SereginNG@mgsu.ru

According to the first group of limit states, the load—bearing capacity, i.e. the stability of the bases, is checked. In this method, the volume of soil displaced as a result of loss of stability is taken as the working area of the base [4].

According to the second group of limit states — calculation of deformations. The calculation of the bases according to the second limit state is the main one, since above-ground structures are deformed with uneven precipitation [5].

When calculating deformations, the compressible working area of the base is taken in the form shown in Fig. 1. This method is used under relatively small loads, when there is no loss of stability of the base and solutions to the mechanics of linearly deformable media can be used.

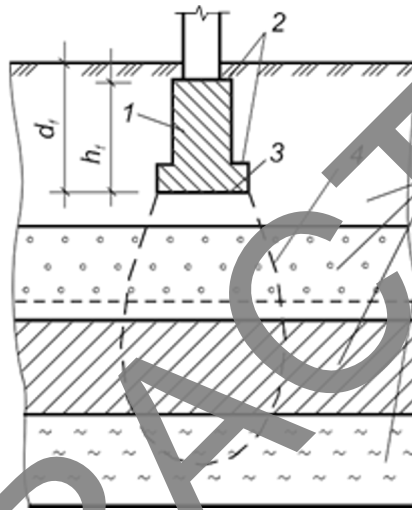

Fig. 1. The structure of interaction between the foundation and the base: 1 - foundation; 2 - horizontal foundation platform; 3 - base of the foundation; 4 - base; 5 - underlying soils.

With a significant external load, a loss of stability of the foundation may occur, accompanied by the extrusion of part of the soil from under the sole of the foundation (Fig. 2).

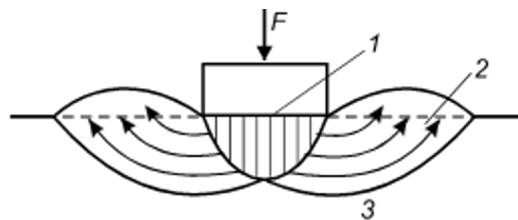

Fig. 2. Distribution of loads on the foundation: 1 - load on the soil under the base of the foundation; 2 - squeezed out soil; 3 - neutral volume of soil.

In this case, a different calculation method is used — by stability. At the same time, the volume of soil that is moved relative to a stationary array as a result of the loss of stability of the base is taken as the working area of the base.

Particular attention is paid when designing foundations to the choice of the depth of laying and the size of the sole of the foundations, which are accepted provided that the deformations do not exceed the limit values. In this case, it is possible to assume a linear relationship between stresses and deformations in most of the volume of the base. This restriction is partially fulfilled when the pressure is evenly distributed over the sole of the foundation, which is less than the calculated resistance of the soil R [6].

The calculated resistance depends on the properties of the foundation soils and the basic dimensions of the foundation. With low- and medium-compressible soils, horizontal occurrence of their layers and small loads, the average pressure on the sole of the foundation usually does not exceed the calculated resistance of the soil ($r_i \leq R$), and the deformation of the base is significantly less than permissible [7].

In such cases, it can be assumed that the conditions limiting deformations are met. Otherwise, it is necessary to proceed to the calculation with a nonlinear relationship between stresses and deformations.

Usually, the calculation requires to establish that the average pressure on the sole of the foundation does not exceed R ; the pressure at off-center loading is on average no more than R , and under the edge of the foundation — no more than $1.2R$ and no more than $1.5R$ at an angle; deformations of the base do not exceed the limit values; the base is stable (if such a check is required); foundations have in each section the necessary strength [8].

Different soils perceive loads from foundations in different ways. Various characteristics of soils lead to the formation of a complex of loads affecting the foundations. Which is the main reason for the dynamics of foundations, leading to deformations of foundations, as well as buildings and structures in general [9].

Loads on foundations and foundations are divided into basic and special [10].

Also, loads on foundations and foundations are classified as normative and calculated, differing taking into account the values of the load reliability coefficients [11].

The main criterion for the reliability of foundations is the unevenness of their precipitation. The calculation of the uneven precipitation of foundations is reduced to determining the highest and lowest values of the precipitation of foundations [12].

The complexity of accurate calculation of the rigidity of buildings and structures does not allow calculating the exact distribution of loads on foundations, which seriously complicates the task [13].

In order not to perform a static calculation of aboveground structures twice, the average value of the load reliability coefficient γ_f is often used for the transition from the total load on the foundation obtained when calculating the first group of limit states — N0 I, when calculating the bases for deformations. Usually, a decreasing coefficient $\gamma_f = 1,2$ is taken.

The calculated load from the weight of the foundation and the soil above its ledges is calculated by the size of the foundation. With the still unknown dimensions of the foundation, this load is approximately estimated within 10... 25% of the load acting on the edge. The verification calculation is carried out according to the accepted dimensions of the foundation [14].

2. Materials and methods

Since the upper layers of the soil have a low load—bearing capacity and are not able to perceive significant loads without significant deformations, special structures - foundations - usually have to be used in the construction of buildings [15].

The foundation is an underground part of the building designed to transfer the load from the building to the underlying soils at some depth. The plane of the foundation, resting on the base, is called the sole. The surface on which the aboveground structure rests, as well as the boundary between adjacent ledges, is called the edge of the foundation. The distance

from the planned ground surface to the level of the sole is called the depth of the foundation [16].

In engineering practice, several types of foundations are used: shallow foundations, pile foundations and deep foundations. The latter have the shape of a well and sink due to their own weight when extracting soil from their internal cavity.

Foundations built on a natural foundation are divided into pile foundations consisting of individual elements, solid strip foundations and foundations made in the form of a solid reinforced concrete slab [17].

When designing foundations, it is necessary to take into account the depth of freezing of the soil [18].

The depth of laying foundations under the internal walls of heated buildings, regardless of the depth of freezing of the soil, is assigned at least 0.5 m from ground level or floor. The same is assigned to the depth of laying foundations in non-spring soils.

According to the design scheme, foundations are divided into ribbon, columnar, solid and pile. Ribbon foundations are made in the form of continuous walls; columnar — in the form of a system of free—standing pillars; solid — in the form of a solid slab of rectangular or ribbed section for the entire building; pile - in the form of separate rods immersed in the ground [19].

By the nature of work under load, foundations can be rigid, the material of which works mainly for compression, and flexible, working mainly for bending.

Ribbon foundations can be prefabricated and monolithic. Monolithic strip foundations are made of concrete and reinforced concrete, rubble, rubble concrete and other materials. At low loads, such a foundation can have a rectangular cross-section. Its width is assumed to be slightly larger than the thickness of the wall, providing ledges of 50... 150 mm on each side. To increase the load-bearing capacity, foundations are made in a stepped form, while the dimensions of the steps are assumed to be 200 ... 250 mm in width and at least 400 ... 500 mm in height [20].

The main structural elements of ribbon foundations are reinforced concrete blocks manufactured industrially. A sand cushion is filled under the blocks, carefully tamped. The vertical seams of the different tiers of the blocks should not coincide [21].

Pillow blocks are made with a thickness of 300 and 400 mm, a width of 1000...2800 mm, and wall blocks are 780...2380 mm long, 300, 400, 500, 600 mm wide and 580 mm high.

Columnar foundations are arranged under the columns of the frame of industrial buildings. Depending on the load on the column, its cross-section and the depth of the foundation, several standard sizes of foundation blocks are used. The dimensions of the foundation blocks: height of 1.8 ... 4.2 m with a gradation of 0.6 m; the dimensions of the sole in plan from 1.5×1.5 m; the dimensions of the column from 0.9×0.9 to 1.2×2.7 m with a module of 0.3 m. Prefabricated foundations can consist of one reinforced concrete block-cup or several blocks. Hollow foundations are used to save material. Foundations with hempen-type columns are arranged under columns of large cross-section or steel columns [22].

Pile foundations are arranged for the construction of buildings on weak water-saturated soils, as well as when the production of a large volume of earthworks for other types of foundations is technically impossible or economically impractical.

The transfer and uniform distribution of the load on the piles is carried out by a special device — a grillage or floor slabs. In accordance with this, pile foundations are divided into grillage and grillless.

In the practice of construction, pile foundations from single piles, band pile foundations, pile bushes and solid pile fields are used. Piles are classified according to various characteristics [23].

The materials for the manufacture of pile foundations are wood, metal, reinforced concrete. Corrosion of the metal significantly limits its use. Therefore, metal piles, as well as wooden ones, have limited use and serve to perform temporary tasks [24]. Piles are installed in the ground by screwing, vibration, indentation and clogging. Piles installed through weak soil on solid ones are called rack piles. Piles that do not reach solid ground, but are located in a weak zone are called hanging [25].

The technological process of making a pile foundation on a construction site, shown in Fig. 3, consists of five stages. At the first stage, the drilling rig forms a well in the ground for the future pile. At the second stage, a pipe of the appropriate diameter is immersed into the well obtained at the first stage of the technological process, which serves as a formwork. At the third stage, a steel reinforcement frame is placed in the pipe. At the fourth stage, the steel reinforcement frame is poured with a concrete mixture. The concrete mixture is compacted with a vibrator. Without waiting for the concrete mixture to cure, the pipe is removed from the raw concrete mortar at the fifth stage. After curing the concrete mixture, the resulting pile is ready for further foundation construction.

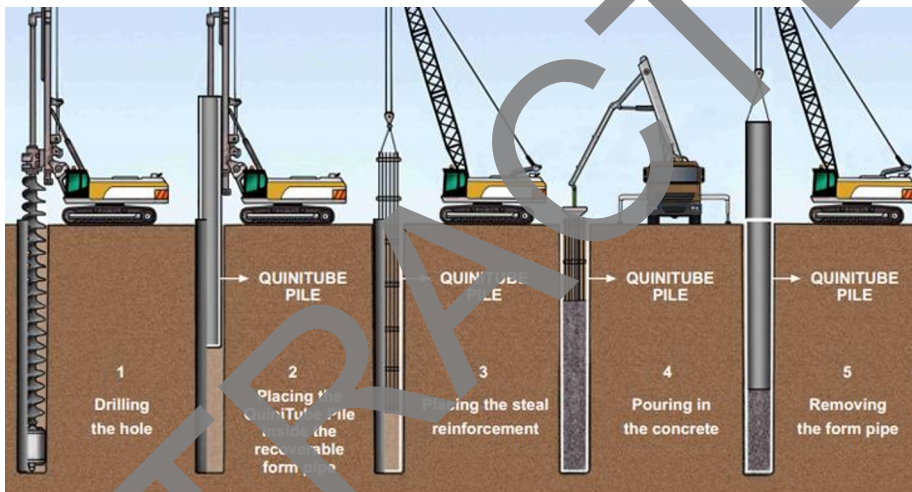

Fig. 3. Technology of pile foundation manufacturing at the construction site.

The advantages of the considered technology for the manufacture of pile foundation include:

- the ability to build the foundation of a building or structure under construction near existing buildings, since this technology belongs to the category of shock-free;
- the foundation obtained by this technology has a large bearing capacity;
- there is a possibility of foundation construction using this technology in any ground conditions.

The disadvantages of the considered pile foundation manufacturing technology are the need to warm up the concrete mixture in winter, since concreting takes place in the field, and the complexity of quality control of well formation.

However, during the construction of buildings and structures, especially on heterogeneous soils in difficult engineering and geological conditions, pile foundations account for approximately 25% of the total volume of foundations under construction. Therefore, research on improving the technology of their construction is very relevant today. Especially technologies that allow, while ensuring the strength and reliability of pile foundations, to reduce the complexity and cost of manufacturing.

One of the most promising ways of constructing pile foundations is the drilling method. The drilling and mixing method for the construction of pile foundations allows fixing all types of structurally unstable and weak soils, regardless of their humidity and the location of the groundwater horizon.

The prospects for fixing soils under the soles of foundations, high mechanization of work, their low cost and a significant amount of local soils in the foundation ensure high efficiency of the drilling mixing method.

This method is characterized by environmental cleanliness and the possibility of application, both for the construction of foundations of new buildings and structures, and for the reconstruction of existing ones.

Many years of experience in strengthening soils confirms the need to improve methods for improving the properties of cement-ground pile foundations. One of them is the method of mechanical activation of soils, which allows to reduce cement consumption and increase the strength of cement-ground pile foundations.

The drilling mixing method for the construction of pile foundations with mechanical activation of soils can be implemented by using drilling machines, drilling rigs, as well as hollow drilling rods that provide forced supply of drilling stock.

The technological scheme for the manufacture of cement - ground piles by the drilling method using mechanical activation of the soil consists of the following operations:

- pit device;
- immersion of the drilling mixer and transfer of the soil to a viscous state;
- filling the well with soil of a viscous consistency;
- drilling of the drilling mixer and the supply of water-grunt cement mortar.

The device of the pit is carried out by drilling a receiving well with a diameter of 0.1 meters larger than the diameter of the pile being constructed and a depth of 0.5 - 2 meters, depending on the length of the future pile and the physical and mechanical properties of the soil. The receiving well is designed to receive an excess of cement-ground mixture that has arisen when water and cement are fed into the ground. The soil extracted from the well is used to prepare a mechanically activated cement-ground mixture. Depending on the physical and mechanical properties of the soil and the amount of binder injected, the depth of the well is determined.

The immersion of the drill mixer and the transfer of the soil to a viscous state is performed by drilling the soil with a paddle drill mixer and supplying water to transfer the crushed soil to a viscous state.

Filling the well with soil of a viscous consistency is carried out by supplying water when the drilling mixer is immersed in the ground. In this case, two processes occur simultaneously: cutting the soil and moistening it to a viscous state.

The drilling of the drilling mixer and the supply of the water-grunt-cement solution occurs by extracting the drilling mixer with simultaneous supply of the water-grunt-cement mixture in the required volume to enter the calculated amount of cement into the ground mass.

The construction of a pile foundation in fluid mixtures, compared with plastic ones, reduces the immersion and extraction time of the drilling mixer by three times by increasing the rotation speed to 130 rpm and reduces the cutting force of the soil by two to three times. And also, the development of the soil by a drilling mixer with the supply of a given volume of water to the well to transfer the soil to a viscous state allows you to obtain the soil of the required degree of grinding.

The main advantages of the drilling method for the construction of pile foundations with mechanical activation of soils are the use of local soil extracted directly from the well as a pile material, and the possibility of installing piles next to existing foundations and other underground structures without exposing them to damage.

3 Results and conclusions

The predominant factor that determines the high efficiency of the use of cement grout in construction is the use of local soils as the main material.

Of particular note are loess-like rocks that occupy 15% of the country's territory. Loess-like soils are widespread in Western Siberia, the Altai Territory and other areas. As a rule, loess-like soils are found in areas poor in stone building materials. For example, in the Omsk region, the transportation of stone materials is more than 500 km, which leads to additional loading of rail and road transport, as well as an increase in the cost of work.

The cost of 1 m³ of stone in the Omsk region is more than 7225 rubles. In this regard, the use of local soils for the preparation of cement as the main material for foundations is of practical interest. Earlier it was also noted that loess soils are the most suitable for cement soil in terms of their physical and chemical properties.

Comparative studies of steel consumption for the construction of a belt foundation made of precast concrete blocks and drilling cement-ground piles with a prefabricated grillage have shown more than two-fold advantage of a belt foundation (Fig. 4).

The calculation of technical and economic indicators was carried out for one linear meter of the walls of low-rise buildings with strip foundations made of precast concrete blocks and foundations on drilling cement piles with a prefabricated grillage at a load of ten tons per linear meter.

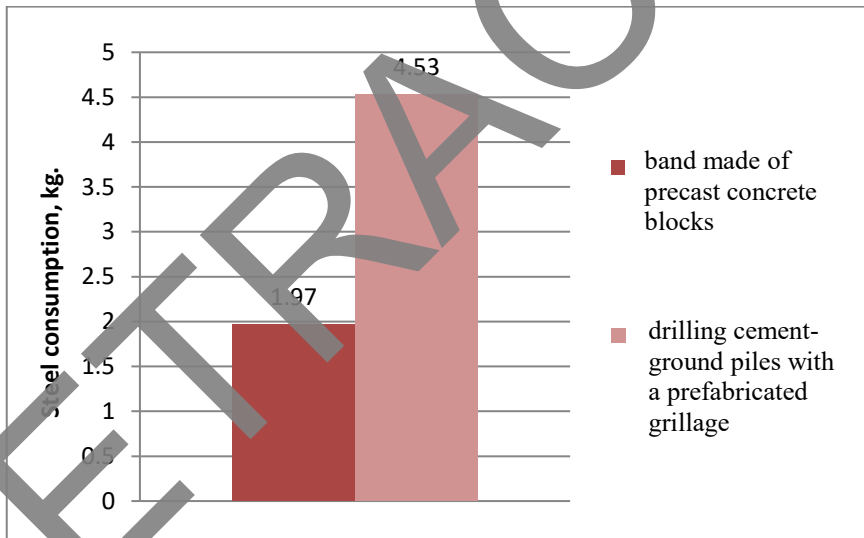

Fig. 4. Steel consumption for the construction of tape and cement-ground pile foundations.

Repeated studies on the same indicator, taking into account also bored concrete piles, gave the same result (Fig. 5).

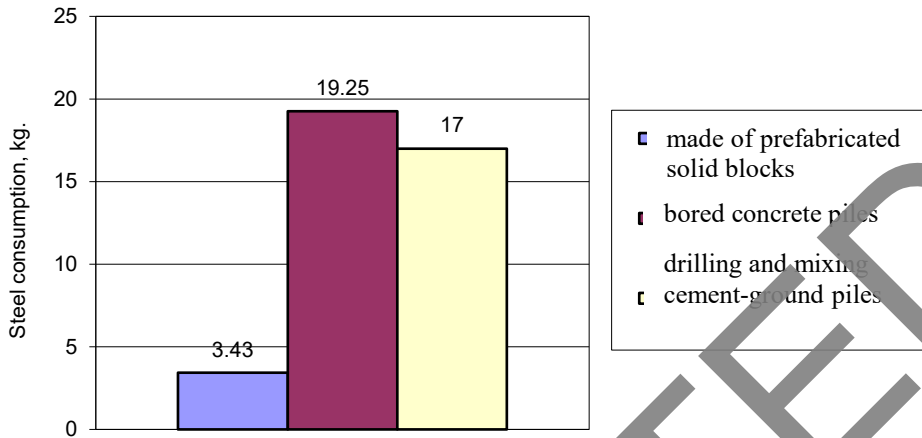

Fig. 5. Steel consumption for the construction of a belt and two types of pile foundations.

However, it is impossible to draw conclusions based on only one indicator. The construction of foundations requires the consumption of not only steel for the manufacture of reinforcement, but also the consumption of concrete, cement, as well as taking into account the complexity of the production of foundation work. Comparative comprehensive studies of the cost of construction of tape, drilling concrete and drilling cement foundations have shown a clear advantage of drilling cement pile foundations (Fig. 6).

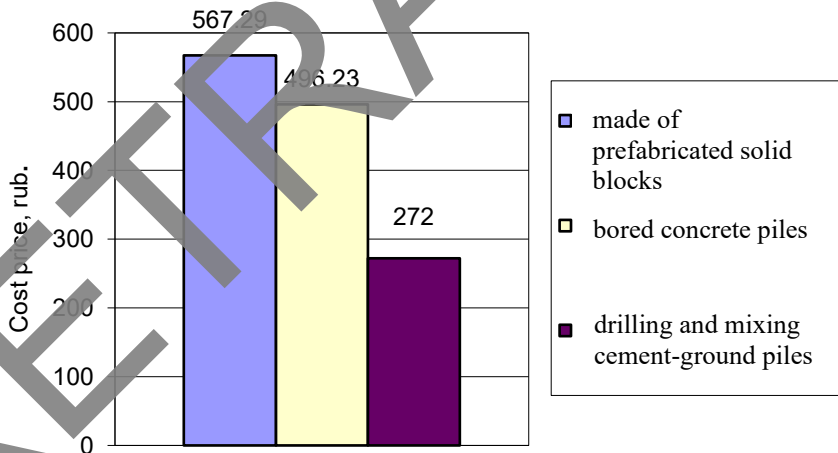

Fig. 6. Comparative comprehensive studies of the cost of construction of foundations of various types.

From which it can be concluded that the construction of pile foundations made of cement on local soils by a drilling method using mechanical activation reduces the shortage of large aggregate, increases the main production indicators, reduces costs due to the lack of work on the removal of soil from the construction site. Since even the soil from the pit is used together with cement as a mechanically activated component. And this guarantees a reduction in the cost of the zero cycle, a reduction in the fleet of vehicles used in construction and the number of maintenance personnel.

The use of bored piles instead of driven reinforced concrete ones gives a serious economic effect, and also allows you to strengthen the subsidence loess soils by cutting through them with cement-ground piles.

References

1. V. I. Zaprudnov, Construction business and materials (St. Petersburg, Lan, 2022)
2. N. G. Seregin, E. A. Egorov, Foundations and foundations of buildings and structures (Moscow, Publishing House of MISI–MGSU, 2022)
3. V. I. Zaprudnov, N. G. Seregin, N. I. Potekhin, Forest Bulletin / Forestry Bulletin **27(4)**, 128-136 (2023) DOI: 10.18698/2542-1468-2023-4-128-136
4. N. G. Seregin, V. I. Zaprudnov, Forest Bulletin / Forestry Bulletin **27(1)**, 114-120 (2023) DOI: 10.18698/2542-1468-2023-1-114-120
5. N. Seregin, Soils During Strengthening of the Construction of Cement-Ground Piles. Fundamental and Applied Scientific Research in the Development of Agriculture in the Far East (AFE-2022) (2023)
6. N. Seregin, Lecture Notes in Civil Engineering **180** (2022) https://doi.org/10.1007/978-3-030-83917-8_43.
7. N. G. Seregin, V. I. Zaprudnov, Forest Bulletin / Forestry Bulletin **25(5)**, 106-110 (2021) DOI: 10.18698/2542-1468-2021-5-106-110.
8. N. G. Seregin, V. I. Zaprudnov, Forest Bulletin / Forestry Bulletin **24(5)**, 104-108 (2020) DOI: 10.18698/2542-1468-2020-5-104-108.
9. N. Seregin, E3S Web of Conferences **57**, 06006 (2020)
10. N. G. Seregin, IOP Conf. Series: Mat. Science and Eng. **953**, 012093 (2020)
11. N. G. Seregin, V. G. Isaev, Information Technology Bulletin **2 (24)**, 172-178 (2020)
12. J. B. Ang, P. G. Fredriksson, J. of Comparative Economics **46**, 616–633 (2018)
13. R. Aguiar dos Santos, E. Rogério Esquivel, J. of Rock Mechanics and Geotechnical Engineering **10**, 986–991 (2018)
14. Z. Lu, et.al., Cold Regions Science and Technology **157**, 4252 (2019)
15. J. B. Ang, P. G. Fredriksson, J. of Comparative Economics **46**, 616–633 (2018)
16. Z. Hong, J. of Corporate Finance **50**, 1–21 (2018)
17. G. Kong, T. Cao, Y. Hao, Y. Zhou, L. Ren, Underground Space **6 (3)**, 1–9 (2019)
18. J. Li, X. Wang, Y. Guo, X. Yu, Ocean Engineering **181**, 109–120 (2019)
19. R. Santos, E. Esquivel, J. of Rock Mechanics and Geotechnical Engineering **10(5)**, 986–991 (2018)
20. Z. Lu, et.al., Cold Regions Science and Technology **157**, 42–52 (2019)
21. R. Zhao, R. Hui, L. Liu, M. Xie, L. An, CATENA **169**, 175–182 (2018)
22. Q. Zhang, M. Shao, X. Jia, X. Wei, Geoderma **338**, 170–177 (2019)
23. H. D. Baraffé, M. Cosson, J. Bect, G. Delille, B. Francois, Electric Power Systems Research **154**, 444–451 (2018)
24. Y. Hong, Y. Wang, J. Wu, L. Jiao, X. Chang, International Biodeterioration & Biodegradation **133**, 116–123 (2018)
25. J. Jayanudin, M. Fahrurrozi, S. K. Wirawan, R. Rochmadi, Engineering Science and Technology **22(2)**, 458–467 (2019)