

# Package for data management of a telecommunication device in a monitoring system

A. V. Sokolova<sup>1</sup>, E. V. Login<sup>1\*</sup>, G. A. Mashkovtsev, and I. S. Grishanov

<sup>1</sup>Emperor Alexander I St. Petersburg State Transport University, 190031, 9 Moskovsky pr., Saint Petersburg, Russia

**Abstract.** In order to identify the role of data storage in the monitoring system of a telecommunications device, a conceptual design method was used, which was based on the basic principles of the Telecommunication Management Network concept, which is a network management system for telecommunication operators. Based on this concept, it was possible to design a data storage model in the monitoring system of a telecommunications device, which clearly reflects the separation of databases involved in the telecommunications network at different levels of the concept. A description of the differences between the databases assigned to each specific level from each other and an explanation of the functional features of each of the databases under consideration, as well as a description of the data circulation process over the network, is presented. The work focuses on describing the contents of the database of a specific telecommunications device, which is the object of control in the communication network, with the possibility of developing an interface to this database, which makes it convenient to search, view and modify stored data. To designate the information stored in the database of a telecommunications device, a fragment of the database was developed containing a set of attributes characterizing the device, their values and parameters of attribute values. The role of the database interface is to enable the user to quickly and easily access the information contained in the database.

## 1 Introduction

The Unified Monitoring and Administration System (UMAS) currently used on the Russian Railways communications network is based on the ITIL methodology, the assessment of which integration into the UMAS was previously carried out in other studies [1]. ITIL supports configuration management, changes, problems and incidents, as well as service provision management, respectively. It provides opportunities to expand the functionality and improve this UMAS by introducing various subsystems into it, for example, a configuration management subsystem, as well as the introduction of various databases. For example, having a database that stores data about a specific telecommunications network

\* Corresponding author: [elinabeneta@yandex.ru](mailto:elinabeneta@yandex.ru)

device will allow you to allocate resources and reduce the load on a common database containing information about the totality of all network elements.

Earlier in studies [1, 2], the TMN concept, together with the description of data exchange protocols in the TMN management system, was considered as one of the modern approaches to building control systems for transport communication networks, on the basis of which it can be concluded that the TMN concept is convenient when building models for managing telecommunications networks. The purpose of this work is to consider the place and role of databases in a telecommunications network and demonstrate the differences between databases that can be used in it by assigning different databases (database, DB) to specific levels of the Telecommunication Management Network (TMN) concept. The concept is described in detail in the materials [3].

In addition, the purpose of the work is to show what data is planned to be stored in the telecommunications device database being developed, identify specific attributes and give examples of their values in order to clearly show the importance of having a database for a managed object represented by a network element. This goal is realized taking into account the results of the work [4] as part of the review of the OAM (Operations, Administration, and Maintenance) toolkit, demonstrating which functions are performed using OAM methods, and, accordingly, making it clear what data needs to be stored in the database being developed.

In the studies [5, 6], various popular database management systems (DBMS) were analyzed with an explanation of their functions, differences, advantages and disadvantages. To indicate the possibility of convenient access to information stored in the database of a telecommunications device, the purpose of this work also includes a description of the database interface, which provides a user-friendly way of working with data, including the ability to add information to the database, delete data, update, query and edit it. In addition to these, other functions can be performed, the implementation of which can be performed by such well-known databases as Oracle, MySQL, PostgreSQL and others. Such databases are predominantly relational, since they are based on the use of Structured Query Language (SQL), which allows the user to interact with the database, sort, select and filter data through simple queries.

## 2 Materials and methods

The principles and standards of the TMN communication network management concept, chosen as the basis for building a conceptual model of data storage in a telecommunications device monitoring system, are described in detail in the literature [1, 2, 3].

Based on the materials presented in these sources, it is possible to display the main points and principles of the concept used, which were applied when building a conceptual data storage model.

The TMN concept provides for five levels, each of which has its own functions, and each of which can include software and hardware involved in the telecommunications network based on their purpose, functionality and role in the communication network.

For clarity, the level structure of the communication network management concept is shown in Fig. 1.

The first, lowest level of the TMN concept is *the network element level (NEL)*. He owns the network elements themselves, which are physical devices such as routers, switches, regenerators, gateways and other devices directly involved in the organization of a communication network. Network channels and paths also belong to this level.

The functionality of this level is determined by the functionality of the network elements themselves, acting at the NEL level as managed objects over which various actions can be performed, the purpose of which may be to optimize the operation of the

device, troubleshooting, etc. The NEL level also includes the functions of self-diagnosis of managed objects performed by means of built-in modules, diagnostic complexes, and the functions of notification of malfunctions in a network element, notification of changes in its parameters.

The agent program available at the NEL level, executed on the basis of software and integrated into the managed object, provides message generation in case of changes in the parameters of the network element when they exceed acceptable limits, and also ensures that this data is sent to the upper level.

The second level is called the *Element Management Level* (EML). He is responsible for ensuring the proper operation of network devices, compliance with measures when working with them, maintaining proper operability of network elements, and in case of changes in device parameters and exceeding their permissible limits, determining the type of faults and their localization. These functions, as well as device configuration and other capabilities are provided at the EML level through the use of monitoring and control tools, OAM tools, with which you can track the current status of network device parameters and draw conclusions about compliance or non-compliance of the values of these parameters with the declared standards.

The EML level differs from the lower level of network elements, first of all, in that, in addition to simply storing data about a telecommunications device, it needs to assess the condition of a managed object based on available information and develop solutions to stabilize the condition. These solutions, presented in the form of control commands, are sent to the lower level, where the agent program, having received and processed them, determines what actions need to be performed on the controlled device and performs these necessary actions.

The third level of the TMN concept is the *Network Management Layer* (NML). Responsible for the entire network as a whole, and not for specific groups of devices in it, this level should perform monitoring and control procedures for the entire set of devices involved in organizing communication in this telecommunications network. The NML layer is responsible for determining the current state of the entire communication network and its individual fragments, securely storing all this information and providing quick and convenient access to it.

As part of the third level of TMN, the security of the telecommunications network is also ensured through the use of various network screens that filter traffic; intrusion detection and prevention systems (Intrusion Detection System/Intrusion Prevention System, IDS/IPS); data encryption.

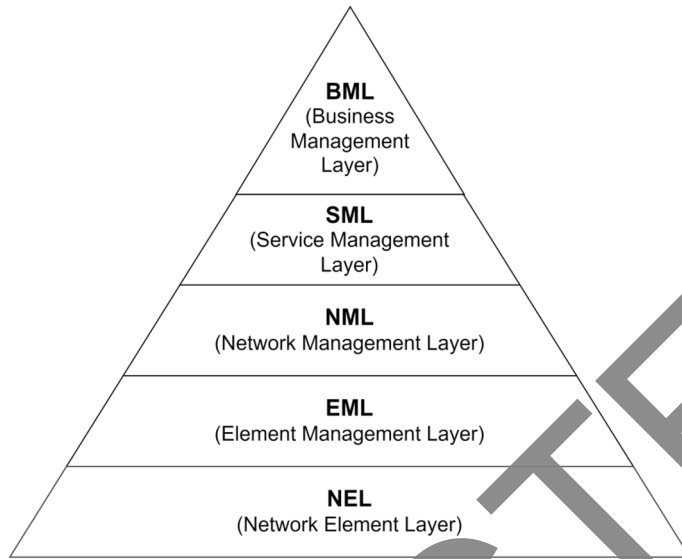

**Fig. 1.** The tiered structure of the TMN concept.

The description of the next two levels of the considered communication network management concept in this paper is limited to a brief explanation of their functions, since, taking into account the designated purpose of the study, these levels do not carry primary importance in describing the place and role of databases related directly to the telecommunications network.

The fourth level, the *service management* level (SML), includes providing billing procedures, determining customer needs, which consist in evaluating the quality of communication provided in accordance with a given tariff. At this level, the presence of a service manager can be noted as an important element for implementing the functionality of the SML level. The service manager is designed as software that allows you to manage network resources, monitor and monitor them, perform billing procedures and determine the quality of communication required by the client. At this level, it is the service manager who is able to ensure the efficiency and reliability of the operator's communication network.

A distinctive feature of the SML level compared to the three listed earlier is that it, as the level responsible for managing services, does not include devices directly involved in the organization of communication. For this reason, the SML level is not considered in this work.

The fifth, topmost, *business management level* (BML) is important for the telecom operator company itself, since it is responsible for working with the organization's finances and its staff. At this level of the TMN concept, various tools can be used to determine the company's development prospects, its strengths and weaknesses, opportunities and threats, for which, for example, SWOT analysis can be used, which is convenient to carry out using Microsoft tools.

The level of business management is responsible for determining the company's place in the market, for developing a business development strategy, but it does not carry the specifics of communication. Therefore, this level, for the previously indicated reason, is also not considered in the framework of this work.

The next method in this work was an *object-oriented approach* to building a database structure, the principles of which are described in detail in the literature [7, 8].

The design of a database fragment was also based on the principles of building relational databases (SQL), described in detail in the literature [9], according to which it is possible to build a chain of interconnected tables containing data about a managed object. The table contains the attributes of the object (data elements), represented as columns, and data records, represented by rows. Records contain sets of attribute values stored in table cells. Attribute values contain data about the properties of the control object. Thus, one entry in the table represents the totality of the object's properties.

An example of a chain of interconnected tables built in accordance with the principle of relational databases is shown in Fig. 2.

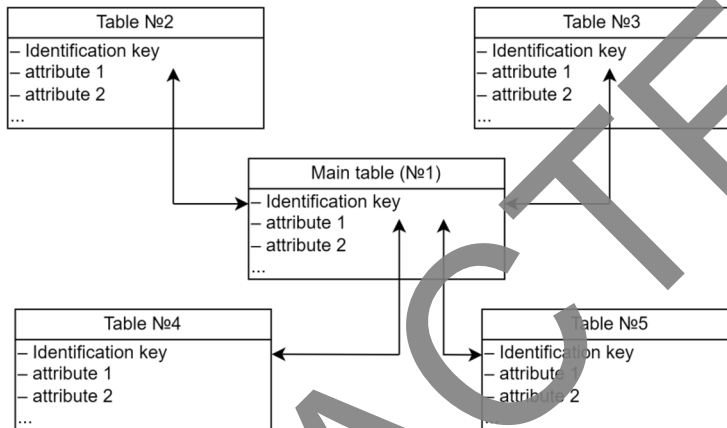

**Fig. 2.** Example of the organization of the relationship between tables in a relational database.

The following method is also based on the principles of relational databases [9]. The environment for developing an interface to a telecommunications device database is MySQL, the principles of which are described in detail in the materials [10, 11].

Being a free, open-source relational database management system, MySQL provides the user with ample opportunities to develop their own database with an interface to it, allowing them to modify and modify the code to achieve their goals.

MySQL is a free software for working with relational databases that provides the ability to create and control a user's own database. The SQL structured query language used is relatively easy to learn, giving the user the ability to interact with the database through understandable queries. All of the above are the advantages of MySQL and determine its choice for the implementation of the goals of this study.

### 3 Results

In accordance with the principles of the TMN concept, a data storage model in the monitoring system of a telecommunications device was designed, shown in Fig. 3.

This model reflects the place of databases assigned to different levels of the communication network management concept. The three levels presented are sufficient to reflect the principles of managing devices on the network, as well as to indicate which data is to be stored.

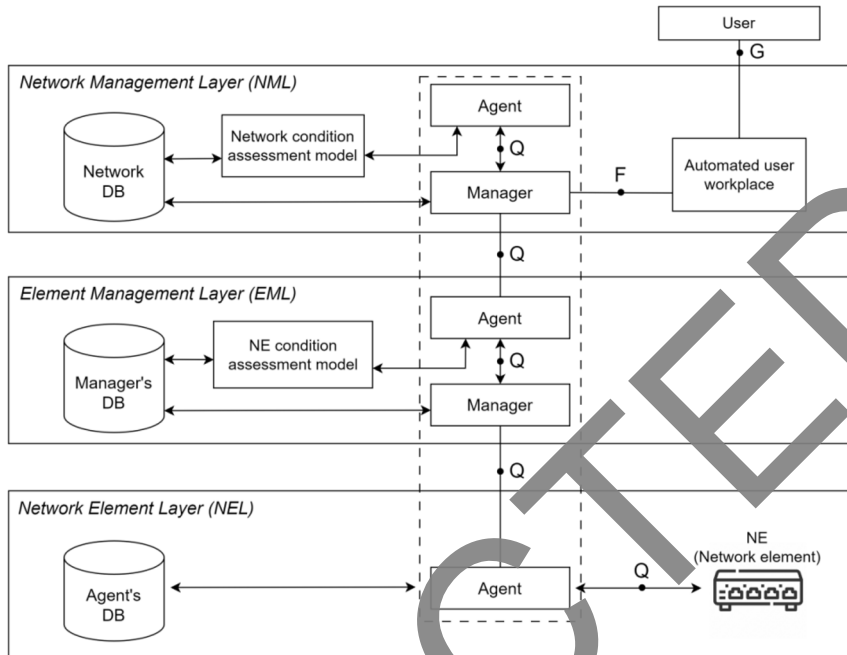

**Fig. 3.** Conceptual model of data storage in a telecommunications device monitoring system.

The model is made as part of a demonstration of the management of one specific network element and the storage of data about it. The network element acting as a control object is illustrated for clarity in the form of a simple switch.

The *lower level of network elements* (NEL) is represented directly by the network element (NE) itself, its agent interacting with NE via the Q interface provided for in the TMN concept within the framework of the SNMP protocol (Simple Network Management Protocol).

The NEL-level database includes all the NE data that the agent receives. The data is stored in its original raw form and presented in full in order to maximize the detail of the description of the characteristics and parameter values of the control object.

When an agent collects data from NE via the Q interface (on request or on schedule), acting within the framework of the SNMP protocol using a specified set of messages, it transmits this data to the Agent's DB.

To the next level, Element management (EML), the NEL agent transmits the already processed and filtered data that is necessary for the EML manager to work. When receiving data from multiple NEL agents in a real network, the EML manager must be limited from an overabundance of incoming information leading to overload. This task is performed by the NEL agent.

At the *element management level* (EML), incoming data is uploaded by the manager to the Manager's own database. From this database, information is transferred to a model that performs an assessment of the state of the control object (NE condition assessment model), which processes the stored data and loads the result back. After that, the manager is notified that the result is ready and can view it from the Manager's DB. Thus, the EML database allows the manager to understand what actions need to be performed on NE to stabilize its condition, and what management commands to send to the NEL agent.

To transfer information to the common network database, the EML layer agent transmits the processed data via the Q interface to the NML layer.

The *network management layer* (NML) has a similar composition and functionality to the EML level. But the database here already contains a much larger amount of information, since it stores data about the entire set of network elements. In addition, the Network condition assessment model, which determines the state of the network as a whole and its individual fragments, network routes, uploads the results to the Network DB.

Also, at the NML level, the user's workplace is designated, communication with which is provided within the framework of the TMN concept via the F-interface. The user himself is placed outside the TMN model and communication with him is shown via a G-interface designed to output information to the user and does not belong to the TMN concept. Thus, the user is provided with the ability to view data on the state of the network, its individual fragments, provided by the evaluation model, in an easy-to-understand form.

Detailed information on the SNMP protocol, within which the interaction of elements in the management network is carried out according to the "manager-agent" scheme, which is the basis of the presented model, is given in the materials [12, 13]. Also, the source [14] describes the interfaces provided for in the concept of communication network management.

The following result of the work performed is a fragment of a database as an element of a telecommunications device monitoring system. The fragment is shown in Fig. 4.

A fragment of the database shows a detailed description of the attributes of one of the n NEN elements provided in the monitoring system. This element, that is, the control object, represents the aggregation router. These attributes describe the control object, characterizing its inherent properties, identifying the object, describing its interfaces, various control methods supported by the device, as well as characterizing the state of the control object itself.

Each of the attributes shown in the database fragment has several values. At the same time, each attribute value has its own parameters. So, in Figure 4, for the attribute ( $A_i$ ) characterizing control methods, two values  $A_{i1}$  and  $A_{i2}$  are given, indicating, respectively, support for OAM methods and support for control protocols. OAM methods make it possible to monitor and manage a network element, identify malfunctions, determine their type and localize problems, which is described in detail in the ITU-T recommendation [15].

A more detailed description of the parameters for the value of the  $A_{i1}$  attribute is provided, which reveals parameters such as  $K_{i71}$ - $K_{i73}$ . The  $K_{i71}$  parameter is represented by a list of OAM methods available to the network element in question.

The list of OAM methods used is compiled in accordance with the specification of the device taken for consideration, available on the official website of N3COM.

In the fragment of the aggregation router database, as an example, for one of the listed OAM methods, a list of parameters of this method is presented. The chosen method is Connectivity Fault Management (CFM), which is described in detail in the source.

The capabilities of the CFM method make it possible to verify the integrity of routes in a telecommunications network by sending a Continuity Check Message (CCM) between the terminal devices of the route. Based on this, the database fragment contains such basic parameters of the CFM method as the route quality indicator, device identifier, frequency of verification and response waiting time, designated  $K_{i721}$ - $K_{i72n}$ .

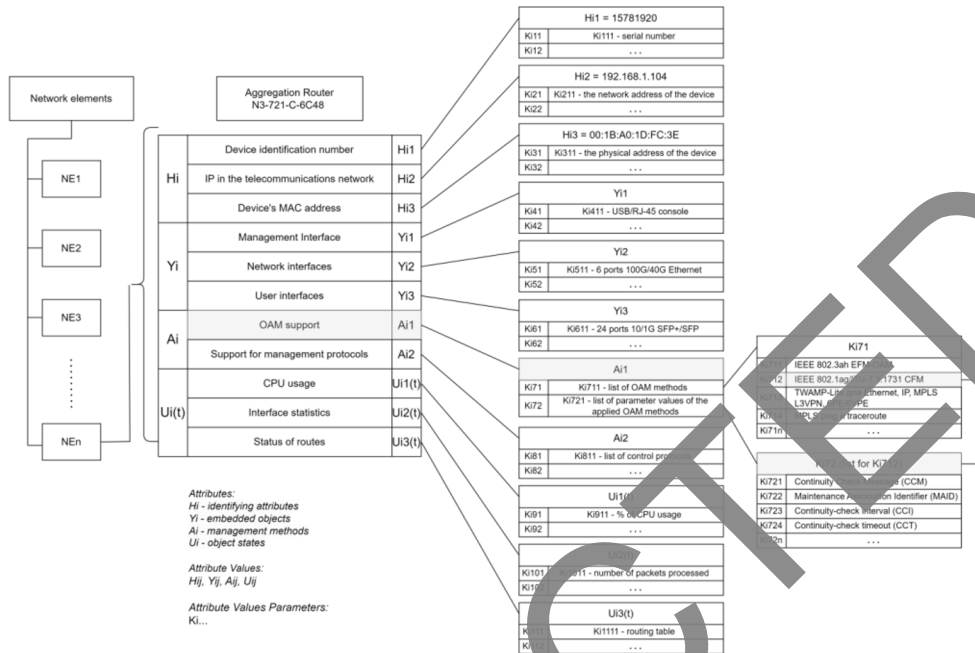

**Fig. 4.** Database fragment.

The result of the development of the interface to the database corresponding to the designed fragment is shown in the screenshots in Fig. 5-7. The design was performed in the MySQL environment.

Each figure illustrates a piece of SQL code that allows the user to easily access the database in order to request information about the management object (OU) stored in it.

In Fig. 5, the USE command allows you to access a specific table in the database. In this case, this table is a table with data about the aggregation router. The SELECT\*FROM command allows you to view all records of the specified table containing information about the network element. The field below, showing records of the individual identifier, device name, as well as its serial number, IP and MAC addresses, demonstrates the result of executing the above commands.

Fig. 6 shows the list of OAM methods supported by the device. The USE command is responsible for selecting the above table from the database, and the SELECT\*FROM command requests data on OAM support. In response, data is output from the database in the form of records containing a list of available methods specified earlier in the fragment in Fig. 4 as parameters Ki711-Ki714.

In Fig. 7, using the same simple commands, a query to the database is implemented to provide the parameters of the Ki712 (CFM) method with the output of their values. As a result of executing the code, records are output from the database with the values of the parameters of the specified method, indicated in the database fragment in Fig.4 under the numbers Ki721-Ki724.

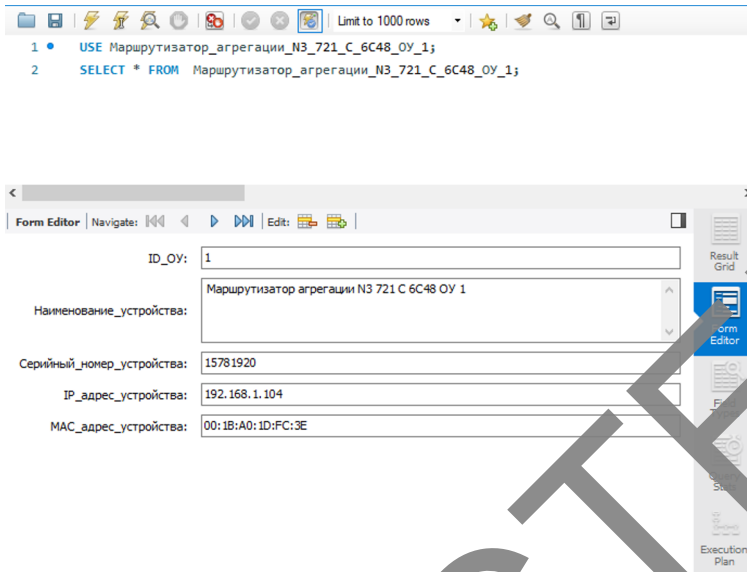

**Fig. 5.** Basic data about the network element (control object) in question.

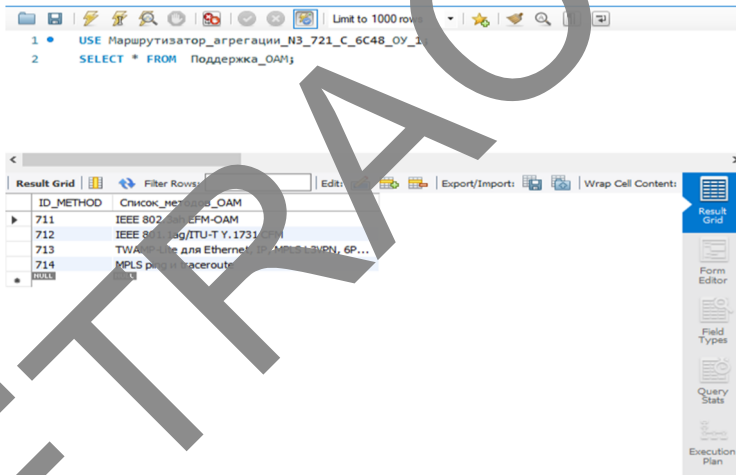

**Fig. 6.** OAM methods supported by the network element.

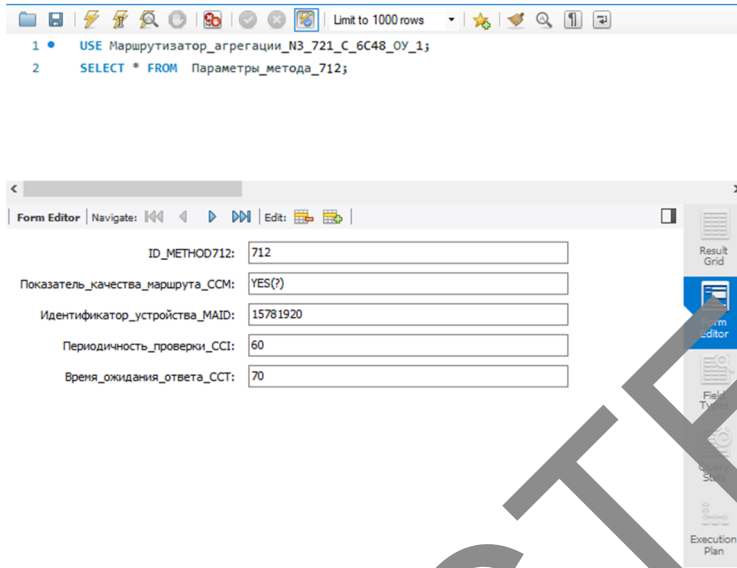

**Fig. 7.** Parameters of the CFM method within the framework of OAM.

## 4 Discussion/Analysis of the results

The development of a data storage model in a telecommunications device monitoring system within the framework of the TMN concept allows you to demonstrate in an understandable way the place and role of databases in the management of telecommunications networks. By assigning different databases to different levels of TMN, it was possible to clearly distinguish the purpose and functions of each of them. This, in turn, will help to assess in further research the amount of data that needs to be stored in a specific database, as well as to evaluate the resources of the management network spent on information processing. These tasks can be implemented by applying the simulation modeling method using AnyLogic software tools.

It is important to note that the management network, built according to the principles of TMN, is built on top of the communication network itself, in which data traffic circulates. This ensures the isolation of the control network from the data transmission network, as well as increases reliability due to the fact that when malfunctions occur in the elements of the communication network, the control network continues to function, identifying the causes of problems and forming teams to eliminate them. Accordingly, it should also be taken into account that the number of resources involved in the management network will not depend on the workload of the communication network. However, given the scale and territorial distribution of the telecommunications network, ensuring accounting and control of management network resources remains an important task, the solution of which is planned to be implemented in subsequent studies.

The fragment of the database of a telecommunications device presented in this paper, as an object of management, designed taking into account the principles of an object-oriented approach, demonstrates which data should be stored in the database of a particular device. In reality, there is much more of this data, which only confirms the fact that it is necessary to introduce separate databases for each device into the monitoring system, in particular in the ECMA on the Russian Railways communication network. A common database stores data about all devices on the network, therefore, it has a significant load. To improve the performance of the database, and consequently improve the efficiency of the

communication network as a whole, it is advisable to distribute the load between different databases, saving the common database from unnecessarily detailed information about each of the network elements in the network. This is exactly what can be achieved by implementing your own databases for network elements, allowing detailed information about the control object to take place and resource in the personal database of the device, and not in the general database of the network.

To demonstrate the interaction with the database of the network element, screenshots of the developed interface were presented in this work, with which the user can view the stored data in an easy-to-understand form by requesting them using simple commands in the language of structured queries. The work done clearly shows that creating your own device database makes sense, because in real conditions there is even more data about the network element, and in the case of storing them all in a common database, there is clearly an uneven load and resource usage at different levels, illustrated by the TMN management network model.

## 5 Conclusion

Based on the conducted research, it can be concluded that databases, like other elements of the network, can be divided into management levels with a distinction between the tasks they perform and the amount of resources spent on data processing.

The demonstration of the data to be stored in the form of a database fragment allows you to visually show the approximate amount of information that is superfluous for the general network database. Therefore, the data given in the fragment is proposed to be stored in the form of records in the tables of its own database of a specific element of the telecommunications network.

The illustrations of implemented queries to the device database reflect the relative simplicity of the task of implementing such a database into the monitoring system, providing a user-friendly and intuitive interface that allows viewing stored data through SQL queries.

It is planned to turn the directions of future research in this area towards calculating the management resources spent by each database, which can be performed using the simulation method.

## References

1. Bagautdinov I.Z., Galyautdinov A.A., The role of the SNMP and TCP/IP data exchange protocol in the network management system // Forum of Young Scientists 9 (13), 2017– pp. 73-78;
2. Management of telecommunication networks // siblec.ru : website. URL: <https://siblec.ru/telekommunikatsii/upravlenie-telekommunikatsionnymi-setyami#6.2>;
3. Mizrahi T., Sprecher N., Bellagamba E., and Weingarten Y., "An Overview of Operations, Administration, and Maintenance (OAM) Tools", RFC 7276, June 2014;
4. Novikov B.A and Levin M.Y., "Comparative Analysis of the Performance of SQL and NoSQL DBMS", Computer tools in education, no. 4, pp. 48–63, 2017;
5. Weisfeld M., Object-oriented approach. 5th international edition – St. Petersburg: St. Petersburg, 2020. – 256 p.;
6. Eldarkhanov A.M., Review of object-oriented DBMS data models // Proceedings of the Institute of System Programming of the Russian Academy of Sciences. – 2011. – volume 21 – pp. 205-225;

7. Popova-Kovartseva D.A., Sopchenko E.V., Fundamentals of database design: textbook. stipend. Samara: Samara University Publishing House, 2019. 112 p.;
8. Challawala Sh., Lakhataria J., Mehta Ch., Patel K., MySQL 8 for Big Data: DMK-Press Publishing House, 2019;
9. Schwartz B., Zaitsev P., Tkachenko V., MySQL to the maximum. 3rd ed. – St. Petersburg: St. Petersburg, 2018. – 864 p.;
10. Mauro D., Schmidt K., Fundamentals of SNMP, 2nd edition. – Translated from English – St. Petersburg: Symbol-Plus, 2012. – 520 p.;
11. Simple Network Management Protocol // [www.cisco.com](http://www.cisco.com) : website. URL: <https://www.cisco.com/c/en/us/td/docs/ios-xml/ios/snmp/configuration/15-s/snmp-15-s-book/nm-snmp-snmpv1.pdf?ysclid=lumrj4ggqm563402126>;
12. Standards, protocols, communication network management interfaces recommended by ITU-T // [siblec.ru](http://siblec.ru) : website. URL: <https://siblec.ru/telekommunikatsii/upravlenie-telekommunikatsionnymi-setyami/2-standarty-protokoly-interfejsy-upravleniya-setyami-svyazi-rekomenduemye-mse-t?ysclid=lumrnxyvz121808874>;
13. ITU-T Rec. G.8013/Y.1731 (11/2013) OAM functions and mechanisms for Ethernet based networks;
14. IP/MPLS equipment line // [n3com.ru](http://n3com.ru) : website. URL: <https://n3com.ru/catalog/n3-721c6/n3-721c4>;
15. Overview of Ethernet OAM // [www.cisco.com](http://www.cisco.com) : website. URL: [https://www.cisco.com/c/dam/global/ru\\_ua/assets/expo2008/download/pdf\\_pre/41.pdf](https://www.cisco.com/c/dam/global/ru_ua/assets/expo2008/download/pdf_pre/41.pdf)