

FEA simulation of harmonics generation from 6-pulse rectifier and their impact over rectifier's transformer

Peter Uzunov^{*}, Krasimir Ivanov, and Nikolai Iliev

Technical University of Gabrovo, 4 Hadji Dimitar, 5300 Gabrovo, Bulgaria

Abstract. In the present work, the operation of a 6-pulse three-phase rectifier supplying a powerful DC consumer is simulated using the finite element method (FEM). The purpose of the simulations is to research the generation of harmonics from the rectifier circuit and to investigate their influence on the transformer supplying the three-phase bridge rectifier. For this purpose, two co-simulations were made. The first of them is realized with the help of the professional Finite Element Analysis (FEA) software - Ansys Electromagnetic Suite. The voltage-driven model of the rectifier transformer for FEA was built and was used in the Ansys Twin Builder software simulation. The resulting current harmonics from the FFT analysis of the current waves with their amplitudes and phases are input into the primary and secondary windings of the transformer current-driven model in the second electromagnetic-thermal co-simulation in Ansys Workbench to calculate the losses in the transformer. These losses are used in the thermal model to account for transformer heating from higher harmonics.

1 Introduction

When a sinusoidal voltage is converted into DC voltage in medium-voltage high-power applications, the switching devices used in the rectifier circuit inject harmonic components into the utility grid. Three-phase rectifiers are used for various low-powers and high-power applications like UPS systems, VFDs, cycloconverters, and AC voltage regulators. Most of these rectifiers are controlled by IGBTs, MOSFETs, or silicon-controlled rectifiers (SCRs). The SCR-based rectifiers are classified based on the number of pulses used for conversion, which are: 6-pulse rectifier, 12-pulse rectifier, 18-pulse rectifier, and 24-pulse rectifier. Mostly, 6-pulse and 12-pulse rectifiers are used in various applications due to economics, product size, and other constraints. The issues related to the higher harmonics generated by such rectifiers have been well studied and solved analytically, experimentally, and by simulation in numerous literary sources and publications [1-6]. Different programs such as Alternative Transients Program (ATP), Matlab Simulink and others are used to simulate the operation of these rectifiers. In the [2] a 6-pulse rectifier is modeled in ATP. Voltage and current waveforms are obtained and the amount of harmonic distortion is calculated. The

* Corresponding author: pmuzunov@yahoo.com

paper [3] presents a miniature hardware model of a 6-pulse controlled rectifier circuit for a monopolar HVDC link. The results of the output voltage are recorded using a digital oscilloscope and are compared with the theoretical values at different firing angles. Performance analysis parameters such as voltage ripple, ripple percentage, and harmonics with and without low pass filter for R and RL load are obtained by varying the firing angle.

Simulation programs such as Matlab Simulink and ATP use different models based on electrical equivalent circuits of transformers and semiconductor elements. For this reason, as well as the strong non-linearity in the magnetic characteristics of the transformers, the obtained results are not very accurate. Numerical methods such as the FEM [5,6] can be used to improve these results. This method allows the modeling of the highly pronounced non-linearity in the characteristics of the magnetic materials used in the transformers supplying the rectifiers. The professional FEA software [7] makes it possible to model the transformer in Ansys Maxwell and the three-phase rectifier in Ansys Twin Builder [7]. The operation of the transformer and rectifier is modeled by solving a coupled simulation task in the Twin Builder environment. As a result of the solution of this coupled problem, the real current waves and voltages on the primary and secondary sides of the transformer are obtained, and with the help of the Fast Fourier Transformation (FFT) applied to them were calculated the higher harmonics of the current and voltage generated by the rectifier. By wye of electromagnetic induction, the higher harmonics generated by the semiconductor elements are transferred from the secondary to the primary side of the transformer and penetrate the electrical network supplying the transformer.

The valuable thing about modeling these processes with the FEM is that it is based on the theory of the electromagnetic field, solving the differential equations with this method in professional FEA software.

In addition to the generation of higher harmonics, the present work also examines their influence on the transformer supplying the rectifier. For this purpose, a second coupled electromagnetic-thermal simulation was made with the help of Ansys Electronics Desktop [7] and Ansys Workbench [8], which calculates the losses from the higher harmonics and the heating of the transformer from them.

2 Modeling of a 6-pulse rectifier

The investigated rectifier is powered by a three-phase transformer with one primary and two secondary windings. The primary is delta-connected. One of the two secondary windings is also connected in a delta, and the second - in a wye. The delta connection of the windings is done to reduce the generated harmonics with the number 3 and multiples of 3. The geometry of the transformer is meshed into a mesh of 27496 tetrahedra.

One three-phase rectifier is connected to each of the two secondary windings, consisting of powerful controllable rectifier elements - thyristors. The two rectifiers work in parallel and supply a powerful DC consumer (700 A, 375 V). The circuit model diagram modelled in Twin Builder is shown in Figure 1.

The three-phase network from which the transformer is powered is modelled with three single-phase sources connected in a wye, generating three sinusoidal voltages with a value of 230 V rms and a frequency of 50 Hz, with a phase difference of 120 degrees (Figure 2,a).

For solving the 3D problem the Transient solver [7] was used. In general, with a sinusoidal supply, the Eddy current solver [9] should be used for the simulation, but the use of the Transient solver is required by the fact that it is desired to model, obtain, and visualize the non-sinusoidal voltages and currents on the primary and secondary sides of the transformer, caused by both the non-linear magnetic characteristics of the transformer [5,6], as well as the operation of the rectifying elements.

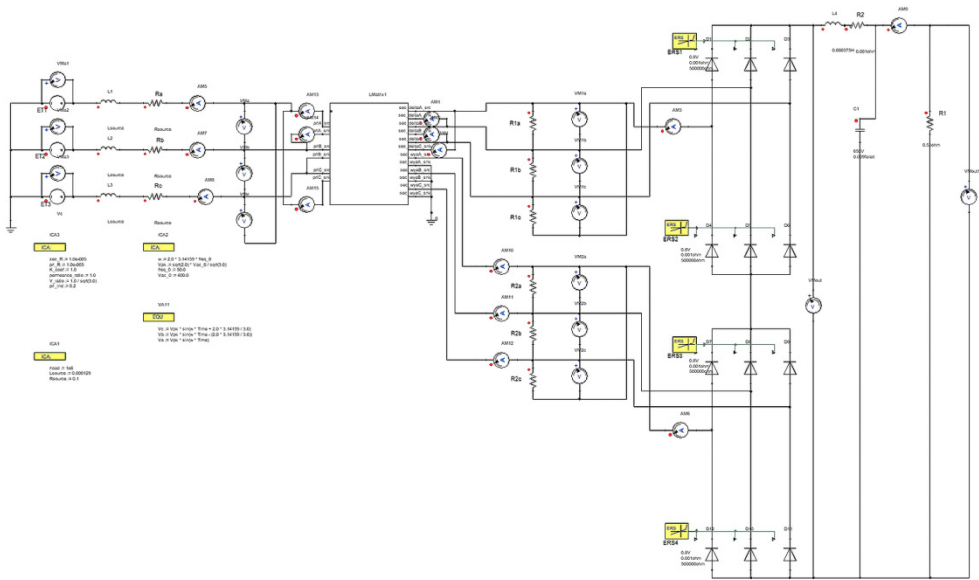
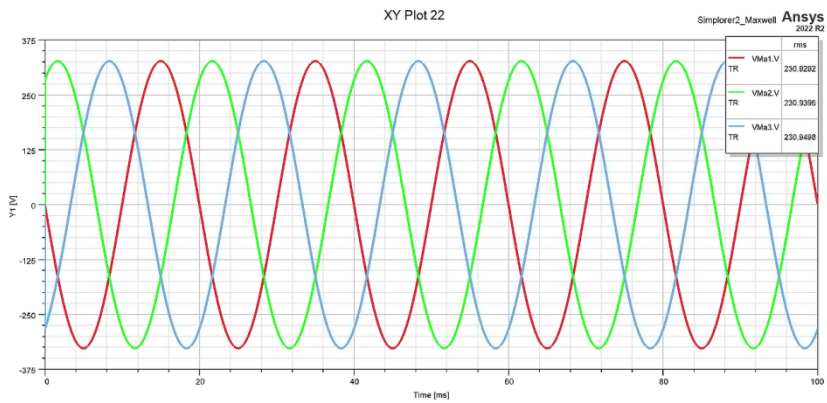
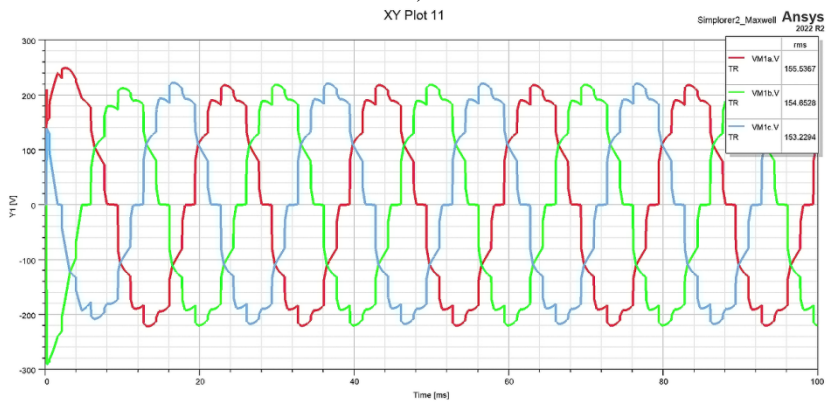

Fig. 1. Electric circuit of the rectifier.



a)



b)

Fig. 2. Voltage waveforms: a) 3-phase supply system; b) primary non-sinusoidal voltages.

3 FEA results of rectifier work simulation

As a result of the co-simulation in Ansys Twin Builder, the waveforms of all currents and voltages in the circuit are obtained. The rectified voltage after the two bridge circuits is shown in Figure 3,a. Its pulsations are visible. To reduce them, an RLC low pass filter is used. As a result of its work, the voltage on the consumer is significantly smoothed – Figure3,b.

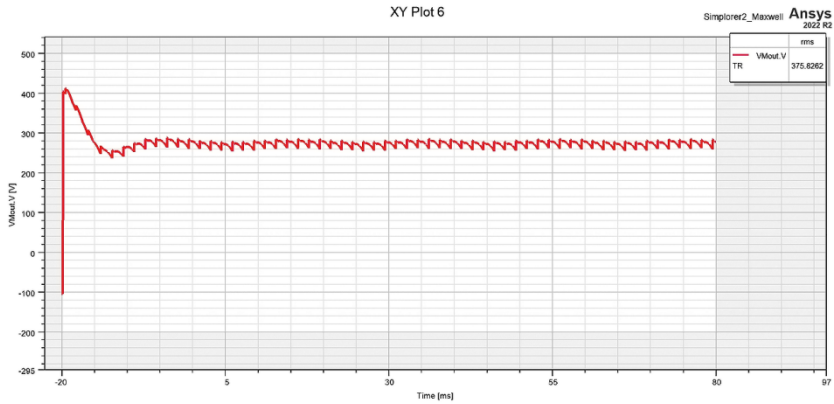

a)

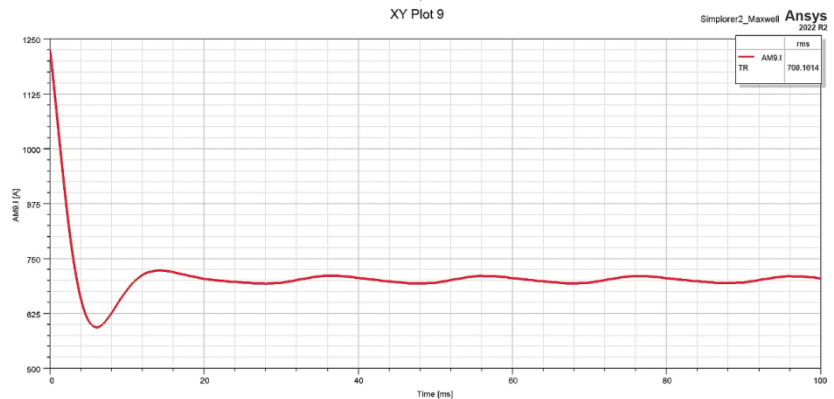

b)

Fig. 3. DC Voltage waveforms: a) before the filter; b) after the filter.

Since the load is purely active, the current before the filter and after it (ie) the current of the consumer have the same forms. The non-sinusoidal waveforms of the currents and voltages in the secondary windings of the transformer are shown in Figure 4 and Figure 5.

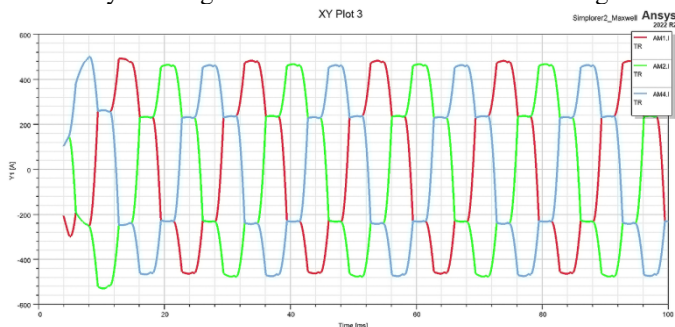

a)

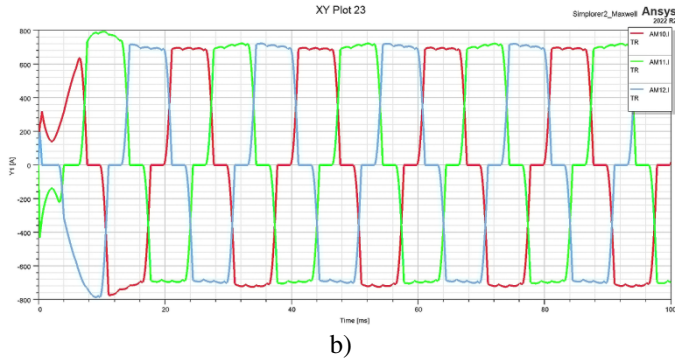

Fig. 4. Waveforms of the secondary phase currents: a) delta-connected winding; b) wye-connected winding.

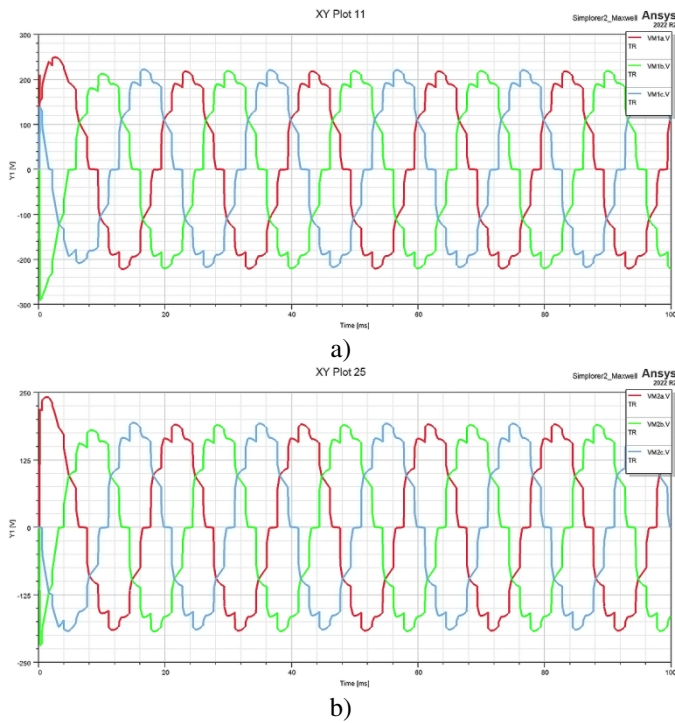

Fig. 5. Waveforms of the secondary line-line voltages: a) delta-connected winding; b) wye-connected winding.

The software makes it possible to obtain the harmonics of the currents and voltages in the secondary side of the transformer using the FFT shown in Figure 6.

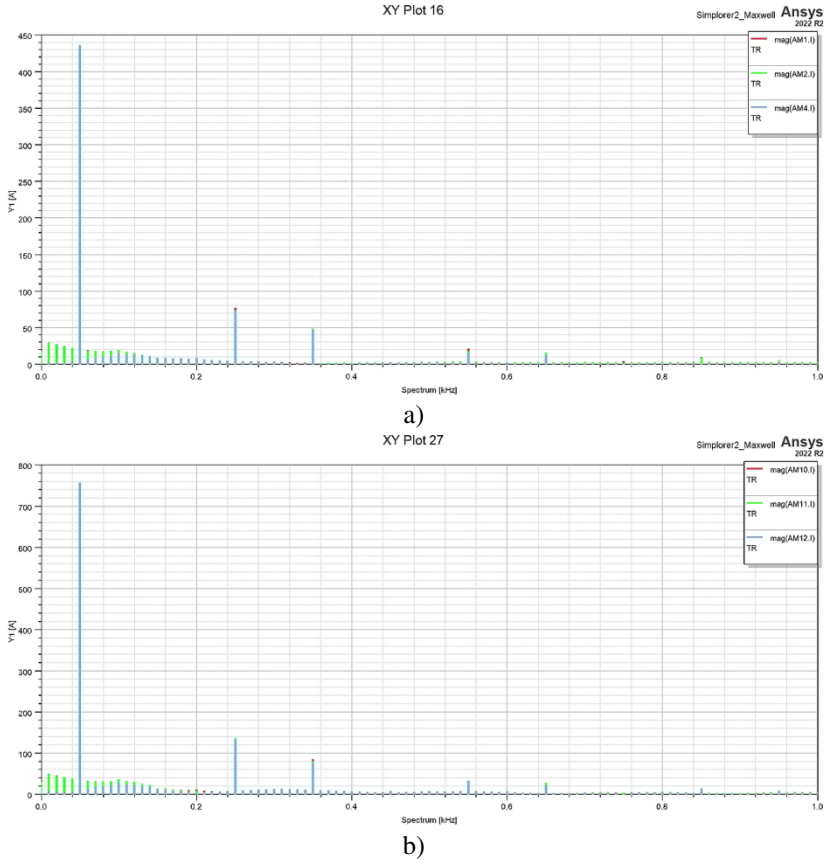

Fig. 6. Results from FFT of the secondary currents in a) delta-connected winding; b) wye-connected winding.

Of the latter, the higher harmonics with the numbers 5,7,11,17,19, etc. are more pronounced. i.e. generated by the rectifier simulation matches those from the theory [4] for this type of rectifier given in equation (1).

$$i_a = \frac{2\sqrt{3}}{\pi} I_d \left(\cos \omega t - \frac{1}{5} \cos 5\omega t + \frac{1}{7} \cos 7\omega t - \frac{1}{11} \cos 11\omega t + \frac{1}{13} \cos 13\omega t - \frac{1}{17} \cos 17\omega t + \frac{1}{19} \cos 19\omega t - \dots \right), \quad (1)$$

where: I_d is the DC of the supplied device; ω is the angular frequency; t is the time.

From Figure 6 and equation (1), it can be concluded that the simulation is done well and gives correct results regarding the number of harmonics generated by the 6-pulse rectifier bridge. All other harmonics calculated by the software have amplitudes far smaller than these and can be neglected for research purposes. Figure 7 shows the non-sinusoidal current waves in the primary winding of the transformer. On the secondary side, these harmonics are transferred by way of electromagnetic induction into the primary winding of the transformer. The harmonics of the phase currents in the primary winding are shown in Figure 8,a, and of the currents in the linear wires after the transformer - in Figure 8,b. As can be seen, the latter are less pronounced than those in the phase currents. The reason for this is the connection of the primary winding in a delta. However, it is these harmonics that

penetrate the network supplying the transformer and become the cause of deterioration of the quality of electricity.

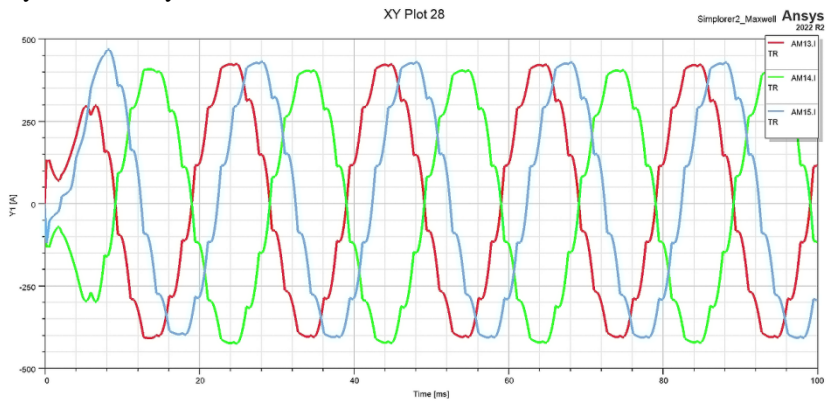

a)

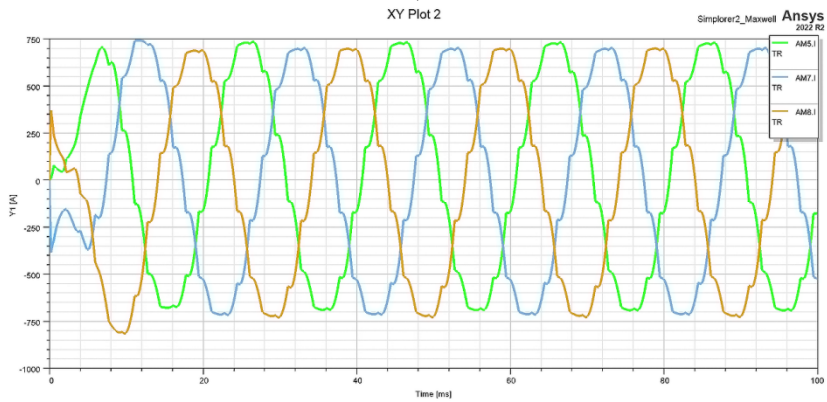

b)

Fig. 7. Waveforms of the primary currents: a) phase currents; b) line currents.

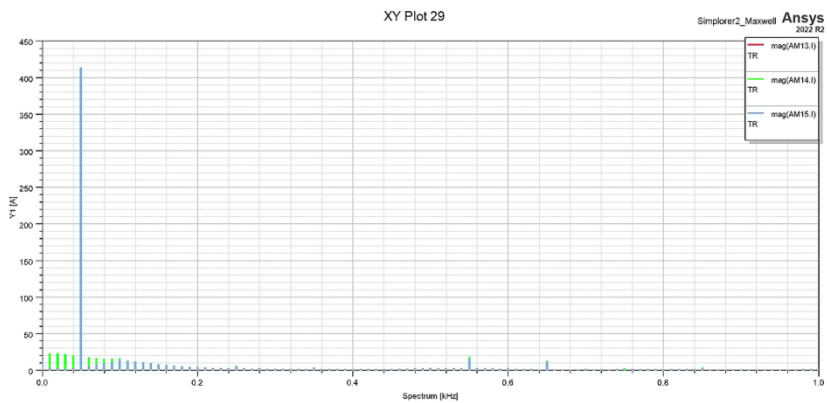

a)

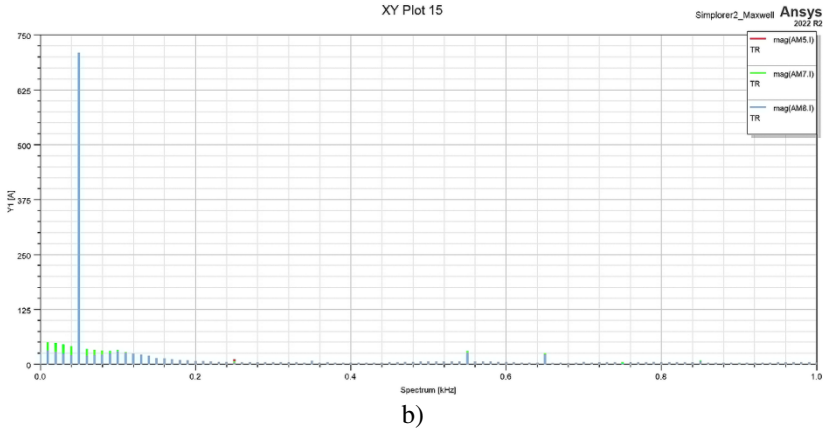

Fig. 8. Harmonics of the primary currents: a) phase currents; b) line currents.

4 Impact of high-harmonics over transformer losses

In the literature, it is described that higher harmonics increase losses and heating of transformers, but it is not indicated which losses increase - in the core or the windings. Given this, in the present work, the losses in the transformer will be calculated in the presence of higher harmonics and without them.

The above simulations give the actual current waveforms in the primary and secondary sides of the 6-pulse rectifier transformer. To calculate the harmonic losses in this transformer, an FEA current-driven model of the rectifier transformer is built. Here, as in the previous simulations, the non-linear magnetic characteristics of the transformer core are set, namely its main magnetization curve and the core losses versus magnetic flux density.

The models of the three windings - the primary and the two secondary windings are supplied with the waves of the phase currents, respectively from Figure 7,a and Figure 4,a and b.

A Transient solver is used to calculate the losses. The results of the loss calculation are given in Figure 9.

The software makes it possible to obtain the harmonic amplitudes and phases of the currents in the primary and secondary sides of the transformer using the FFT.

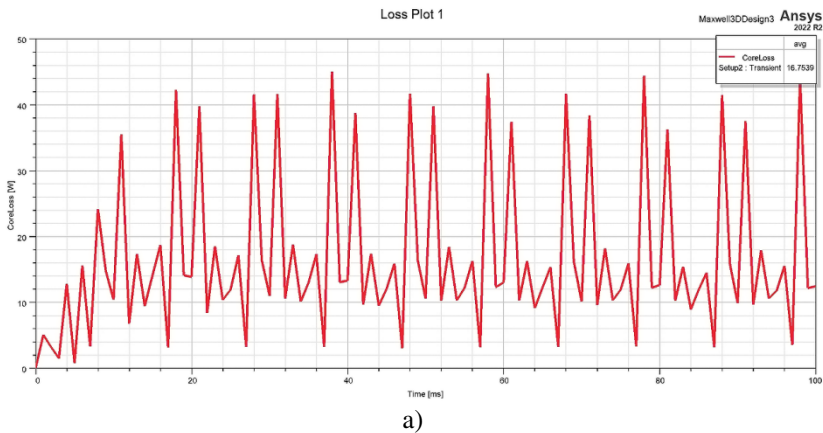

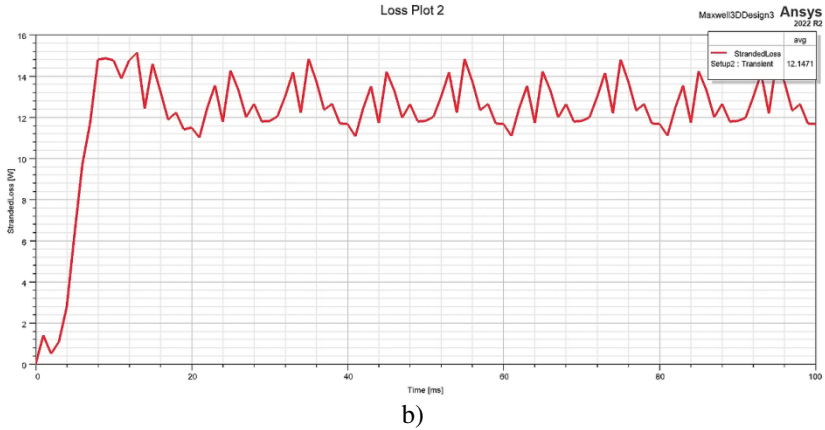

Fig. 9. Losses with harmonics: a) core loss; b) AC loss in windings.

To make a comparison, the losses with a sinusoidal supply of the transformer should also be calculated. For this purpose, the coils are supplied with the fundamental current harmonics at 50 Hz, calculated in the FFT analysis. The calculated losses in this case are shown in Figure 10.

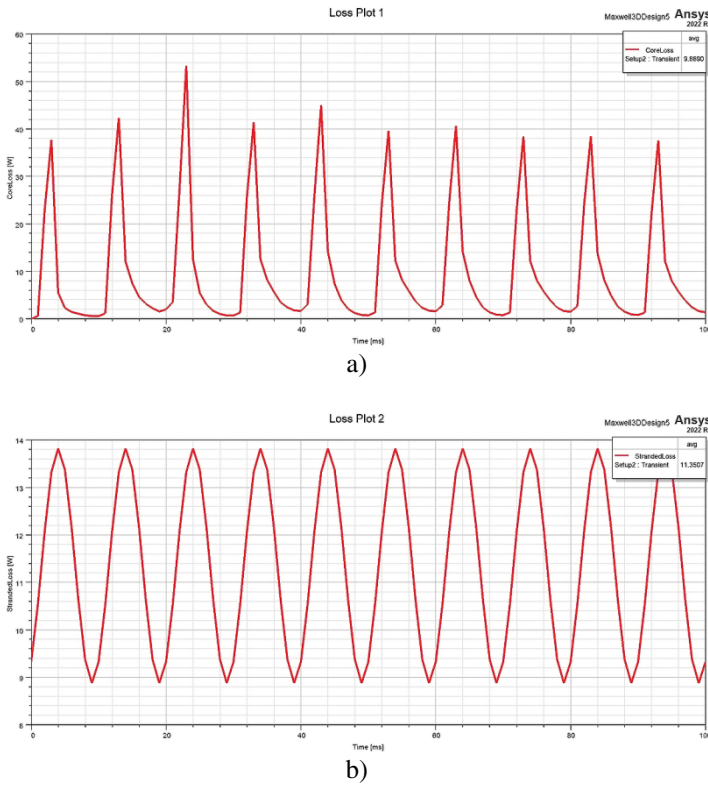

Fig. 10. Losses without harmonics: a) core loss; b) AC loss in windings.

Table 1 compares the losses calculated in the two cases.

Table 1. Calculated losses.

Losses, W		
	With harmonics	Without harmonics
Core	16.75	9.89
Windings	12.15	11.35

From the comparison, it is found that the main difference is in the core losses. In the presence of harmonics, they increase from 10 to 17 W. The reason for this is the increase in hysteresis losses associated with the high frequency of higher harmonics.

Due to the low frequency of the supply voltage - 50 Hz, and accordingly of its higher harmonics, the active resistance of the windings does not increase significantly and this does not change the losses in the windings.

5 Thermal FEA of transformer

To investigate the heating of the rectifier transformer by the high harmonic losses, a coupled electromagnetic and thermal problem must be solved. With it, the losses calculated in the electromagnetic FEA are transferred to the thermal model. The coupled problem was solved using the software Ansys Workbench 2022 R2 [8].

The geometry of the model is meshed on a mesh of 7061 tetrahedra and 17083 nodes.

To correctly define the thermal model, it is necessary to map the losses in the core and windings calculated in the electromagnetic FEA.

As boundary conditions (BC) ambient temperature of 400C and a heat transfer coefficient of 10 W/m²C were used because air-forced cooling for the transformer was used.

For solving the thermal field the Static thermal solver [9] was used. The distribution of the thermal fields is shown in Figure 11.

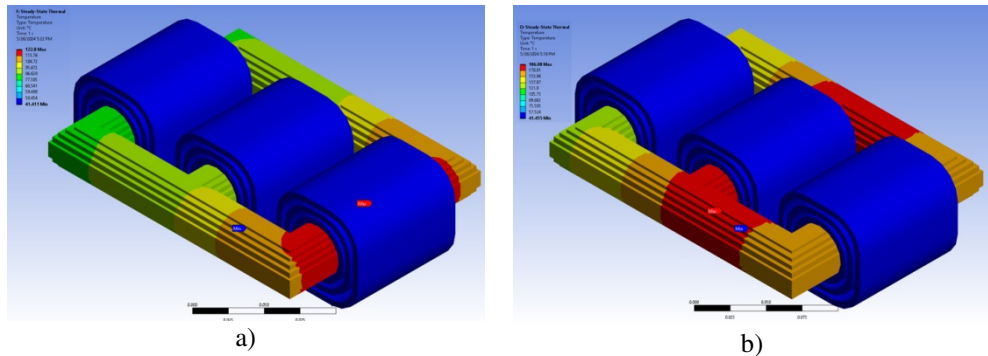

Fig. 11. Thermal field: a) without harmonics; b) with harmonics.

From figures is seen that the presence of harmonics leads to additional heating of the transformer core, supplying this powerful rectifier. This is due to the increase in hysteresis losses due to the influence of higher harmonics. In Table 2, a comparison is made between the maximum temperatures to which the core is heated in the presence of higher harmonics and a sinusoidal power supply without them.

Table 2. Maximum temperature of core, °C

Without harmonics	With harmonics	Increase, %
122.8	186.08	51.53

6 Conclusion

The FEM simulations carried out in the present work prove that powerful three-phase rectifiers generate a lot of harmonics, which through the transformer enter the supply network. The reasons for the generation of these harmonics are the operation of the semiconductor elements in the bridge rectifier circuits and the non-linearity in the magnetic characteristics of the transformer core material. Conventional three-phase rectifiers cause harmonics pollution at the input current side, and therefore bring some hazard to the AC electric network and the other electronic equipment, as shown in Figure 2,b.

The higher harmonics generated by the operation of the semiconductor elements lead to an increase in losses in the transformer feeding the rectifier. As is well known there are two main types of losses in this transformer - in the windings and the ferromagnetic core. As the simulations show, the harmonics mostly lead to an increase in core losses, while the increase in winding losses is insignificant. The reason for this is the higher frequency of the harmonics and the associated increase in frequency-dependent hysteresis losses and eddy currents in the core material.

The losses in the copper of the windings do not increase significantly, since the investigated transformer operates at an industrial frequency, and accordingly, the frequency of harmonics is not so high as to increase the resistance of the wires and, accordingly, the Joule losses, as is the case, for example, with the high-frequency transformers of the modern power electronics.

This is well proven by the calculated temperatures during the analysis of the temperature field - the temperature of the core, but not of the coils, increases significantly.

These conclusions about the influence of higher harmonics on the losses and heating of the rectifier transformer apply in full force to the influence of higher harmonics on transformers in general, operating in various power facilities with industrial frequency and the power transmission network.

The authors of this work express their gratitude to Eng. Mark Christini - Principal Application Engineer - Ansys, Inc., USA, for valuable advice on FEM modeling.

References

1. J. Schlabbach, D. Blume, T. Stephanblome, *Voltage Quality in Electrical Power Systems*, London, UK, (2001)
2. J. Jineeth, K.R.M. Nair, R. Krishnan, M.B. Varrier, *Development of a FEM-based approach for Estimation of Leakage Reactance in Multi-Winding Rectifier Transformers and Experimental Verification*, in Proceedings of the 5th International Conference on Condition Assessment Techniques in Electrical Systems, CATCON, 3-5 Dec. 2021, Kozhikode, India (2021)
3. M. Batni, R. Madhu, B.R. Dinesh, N. Dinesh, *Modeling and analysis of 6 pulse rectifier used in HVDC link*, in Proceedings of the International Conference on Power and Advanced Control Engineering, ICPACE, 12-14 August 2015, Bengaluru, India (2015)
4. T. Hristova, *A model based on current harmonics for controlling the induction motor of a crusher*, in AIP Conf. Proc. 18 August 2022; 2570 (1): 030006, 25–27 November, Ruse, Bulgaria (2021), <https://doi.org/10.1063/5.0099903>
5. P.M. Uzunov, *Transformers and power quality: Part 1. Modeling and researching generation of higher harmonics of small single-phase transformers supplied to domestic and industrial consumers*, J. Transformers magazine, Vol. **3**, Issue **3**, pp. 82-88 (2016)

6. P.M. Uzunov, Transformers and power quality: Part 2. Modeling and research generation of higher harmonics of small three-phase transformers supply industrial consumers, *J. Transformers magazine*, Vol. **4**, pp.112-117 (2016)
7. Ansys EM Suite 2022 R2, Online documentation, Available through: <https://ansyshelp.ansys.com>.
8. Ansys Workbench 2022 R2, Online documentation, Available through: <https://ansyshelp.ansys.com>.
9. J. Li, T. Abdallah, C. R. Sullivan, *Improved calculation of core loss with nonsinusoidal waveforms*, in Conference Record of IEEE Industry Applications Conference. 36th IAS Annual Meeting, 2001, pp. 2203–2210, (2001)