

# Design of a photovoltaic fast-charging station for electric three wheelers vehicles in West Africa

Ababacar Thiam<sup>1,2\*</sup>, Serigne Mourtalla Ndiaye<sup>1</sup>, Mouhamadou Fadilou Ndiaye<sup>2</sup> and Ibrahima Ka<sup>3</sup>

<sup>1</sup> Efficiency and Energetics Systems Research Group, Alioune Diop University, PO:30, Bambey, Diourbel, Senegal

<sup>2</sup>Laboratoire Eau, Energie, Environnement et Procédés Industriels, Ecole Supérieure Polytechnique, BP: 5085, Senegal

<sup>3</sup>Equipe de recherche Energie, Mécanique, Matériaux et Aérospatiale, Ecole Polytechnique de Thiès, Senegal

**Abstract.** Electric tricycles are one of the most promising options for reducing CO<sub>2</sub> emissions in sub-Saharan Africa, with lower energy requirements. They are also suitable for transporting passengers and goods in rural areas of sub-Saharan Africa, where urbanization is rife. The lack of recharging infrastructure is holding back the development of tricycles. This paper proposes a methodology for the design of a photovoltaic (PV)-battery stand-alone fast charging station for electric tricycles in Thienaba, Senegal. An ultra-fast charging station powered by photovoltaic panels was designed, modelled and simulated using the Matlab/Simulink platform. The results of this work gave a photovoltaic array with a peak power equal to 45 kW. At least, eight tricycles can be charged between 11 am and 2 pm. At the same time, the storage system can be charged up to 70% of its total charge.

## 1 Introduction

The market for electric vehicles(EV) is growing worldwide. Sales of EVs have doubled in 2021 compared with 2020, reaching 6.6 million [1]. China, Europe and the United States account for almost two-thirds of sales. EV sales in Africa are low compared with other regions of the world but have increased by 90% in 2021[1]. A clean transition to electric vehicles would eliminate unreliable fuel supplies in sub-Saharan Africa. Many sub-Saharan countries have adopted e-mobility projects, including Ghana, Sierra Leone, Côte d'Ivoire and others. In 2019, Senegal launched a project to replace motorbike taxis with electric tricycles. The ultimate aim of the project is to provide 230,000 drivers with this new type of transport to help create green jobs. Tricycles can be used to transport both passengers and people and remain one of the most widely used means of transport in sub-Saharan Africa. Electric tricycles have the advantage of smaller battery packs and lower energy requirements [2]. Electric tricycles are a suitable means of transport in rural areas of sub-Saharan Africa, which is now undergoing increasing urbanization. At present, one of the main problems associated with the development of tricycles is the lack of recharging infrastructure. The tricycle

---

\* Corresponding author: ababacar.thiam@uadb.edu.sn

batteries are recharged in the homes of the drivers or owners. Charging takes a long time, up to 2 hours. The unavailability of the electricity network is also a limiting factor. Only 50.6% of people in sub-Saharan Africa have access to electricity [3]. Of those without access to the electricity grid, 80% live in rural areas. To remedy this situation, fast-charging stations using renewable energy sources should be considered. Sub-Saharan Africa has significant solar energy potential. Consequently, the most likely source for recharging tricycles is photovoltaic solar energy. The performance of photovoltaic modules is increasing and the price of photovoltaic panels is falling. A great deal of research has been carried out into photovoltaic charging stations. Domínguez-Navarro et al [4] have studied the design of an ultra-fast charging station integrating renewable energy sources and a storage system. The main drawback of ultra-fast charging stations is their high power. The use of renewable energy sources can improve the profitability of a station, and the presence of a storage system can balance out the intermittent nature of the renewable energy source. Mouli et al [5] have developed a three-port, 10 kW bi-directional converter for charging EVs using photovoltaic panels. The 10 kW prototype produced and tested has a peak efficiency of 95.2% for PV-EV. Omran et al [6] proposed a methodology for the optimal sizing of an EV fast-charging station in Cairo, Egypt. The study aims to minimize the total system cost and ensure system reliability by obtaining the optimal number of PV modules and storage units. Ibrahim E. Atawi et al [7] carried out work on the analysis and design of an autonomous photovoltaic powered charging station in Saudi Arabia. The system was modelled and simulated using the Matlab/Simulink platform and a prototype was built to validate the numerical model. Aqib Shafiq et al [8] studied the design of photovoltaic charging for bicycles in the state of Azad Jammu and Kashmir in Pakistan. The energy cost is \$ 0.0962 for the system without storage and \$ 0.191 for the system with storage compared to \$ 0.20 for the existing system. Despite the significant contributions in studies on the design of charging stations based on photovoltaic panels, no work to our knowledge has been carried out in Sub-Saharan Africa. Our study focuses on the design of an ultra-fast charging station for electric tricycles in the rural commune of Thienaba in Senegal. An analysis of the solar resources at the site was carried out. The various components of the charging station were designed. The photovoltaic charging station was modelled and simulated using the Matlab/Simulink platform. A charging station management strategy has been analyzed.

## 2 Methodology

### 2.1 Site selection

Located at latitude 14.45° N and longitude 16.48° W, the commune of Thienaba is in the administrative region of Thies in Senegal (Fig. 1). The commune covers an area of 158 km<sup>2</sup> and has a population of 28,550[9]. The commune has many economic and agricultural activities, including cashew nut cultivation and processing, livestock farming and trade. It also hosts an annual religious event, attended by several thousand people. All these activities contribute to the use of means of transport in the commune. Solar irradiation values for the area were obtained from the PVGIS-Sarah2 database over the period 2011-2021[10]. The average values of monthly solar irradiation are shown in Figure 2. Monthly irradiation is always above 150 kWh/m<sup>2</sup>/month.

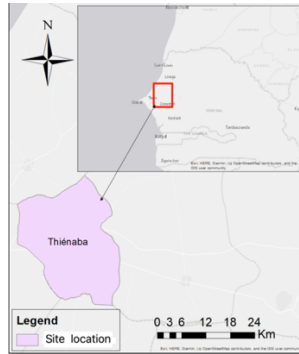

**Fig.1.** Map of the municipality of Thienaba

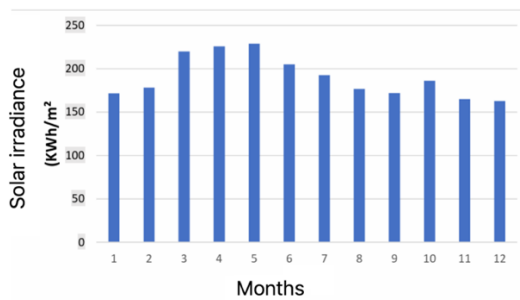
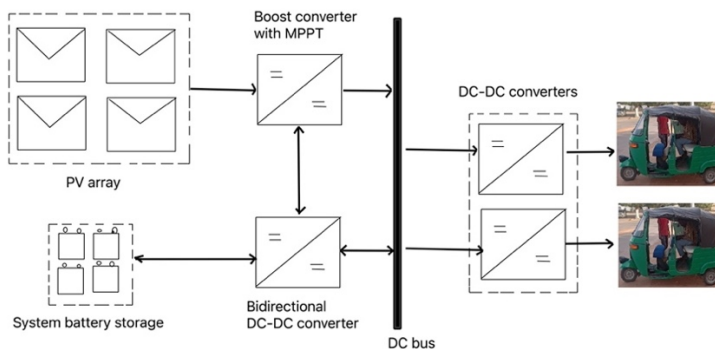

**Fig.2.** Monthly solar irradiance

There are more than 100 electric tricycles in circulation in the municipality. A tricycle has a power of 1 kW and can reach a speed of 25 km/h. The motor is powered by an electrochemical battery with a capacity of 160 Ah and a voltage of 48 V-60 V. The batteries are charged from the mains and take around two hours to charge. Operating a tricycle can earn \$13.17 a day, making it a very important source of income for drivers and tricycle owners. However, the long recharging time is an obstacle to the development of electric mobility in the municipality.

## 2.2 System model

The schematic diagram of the proposed PV-battery autonomous fast charging station for electric tricycles is shown in Figure 3.



**Fig.3.** Photovoltaic ultra-fast charging station

### 2.3 Flowchart

The various stages of this work are summarized in Figure 4. The work begins with an assessment of the site's solar resource. The station loads are evaluated. The capacity of the photovoltaic field and the storage system are also determined, along with the various inverter components. A numerical model of the charging station is implemented in Simulink to determine the electricity production, the load of the tricycles and that of the station's storage batteries.

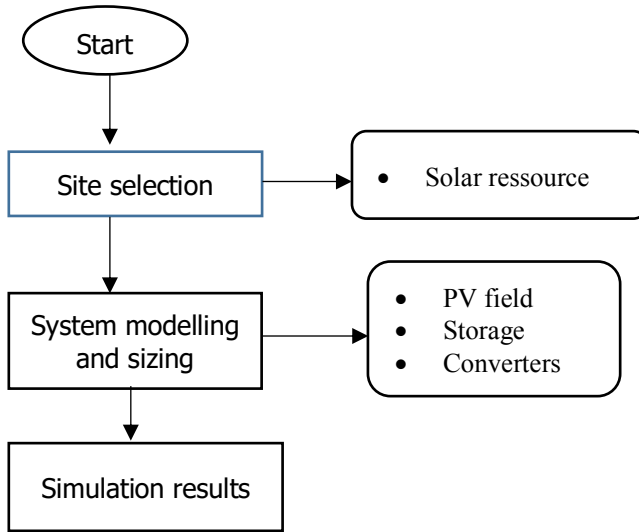

**Fig.4.** Flow Chart for the Design of tricycle Charging Station

## 3 Modelling of PV fast charging station

### 3.1 Photovoltaic field modelling

The electrical power generated by the PV array depends on the amount of solar irradiance and the photovoltaic cells temperature. Many models for estimating the output of a photovoltaic array have been proposed in the literature. In this work, the power produced by the array is modelled by the following equation [11,12]:

$$P_{ph} = N_{pv} P_{max,mod} \frac{G(t)}{G_{ref}} [1 - K_t (T_c - T_{ref})] \quad (1)$$

Where  $N_{pv}$  is the module number,  $P_{max,mod}$  is the maximum power of module,  $G(t)$  is the solar insolation in  $W/m^2$ ,  $G_{ref}$  is the reference solar insolation of  $1000 W/m^2$ ,  $T_c$  denotes the cell temperature in  $^{\circ}C$ ,  $T_{ref}$  is the reference cell temperature of  $25^{\circ}C$ , and  $K_t$  is the temperature coefficient of the utilized PV module.

### 3.2 Storage system modelling

The batteries are used to store excess energy from the PV array for use in the charging station.  
 - When the production of the PV array is greater than the charging demand, the state of charge of the battery can be described by [13] :

$$C(t) = C(t - 1)(1 - \sigma) + \eta_b[E_{pv}(t) - E_L(t)] \tag{2}$$

- When the load demand is greater than the energy generated by the PV array, the batteries are in a state of discharge. The available capacity of the batteries at any time can be expressed as follows :

$$C(t) = C(t - 1)(1 - \sigma) + [E_L(t) - E_{pv}(t)] \tag{3}$$

### 3.3 Total daily load of the station

The average daily power demand of an EV ( $P_{ev}$ ) is the power required to increase the state of charge of the EV battery from an initial value of 20% to a final value of 95% over a daily charging period:

$$P_{ve} = C_{ev} \frac{DOD_{max}}{T_{ch}} \tag{4}$$

Where  $C_{ev}$  is the nominal capacity of the vehicle battery in kWh, DOD is the maximum depth of discharge and  $T_{ch}$  is the estimated charging time of 30 minutes.

The average daily charging energy for tricycles ( $E_{ev}$ ) is calculated as follows:

$$E_{ev} = N_p D(t) P_{ve} \tag{5}$$

$D(t)$  is the daily time-dependent duty cycle of the station.

The station's total daily load demand is:

$$E_L = \frac{E_{ev} + E_b}{\eta_s} \tag{6}$$

$E_b$  : basic station energy (lighting)

$\eta_s$  : overall system performance

The sizing results for a PV charging station for 4 hours of operation are  $P_{ev}=15$  kW;

$E_{ev}=33.7$  kWh and  $E_L=34$  kW.

### 3.4 Fast charger DC-DC

The primary function of the charger is to adapt the bus voltage and the electric vehicle battery so that charging can be carried out efficiently. The charger used is type SAE J1772 2009 with a voltage of 400 V, a maximum power of 240 kW and a maximum current of 400 A [14].

### 3.5 PV array sizing

The characteristics of the chosen PV module are given in table 1. The power of the panels to satisfy such consumption is given by:

$$P_c = \frac{1000 E_j}{k E_i} \tag{7}$$

$k$  : coefficient de correction

$E_j$  : Daily energy consumption

$E_i$  : Average daily irradiance

**Table 1.** PV module characteristics.

Parameters	Value
$P_m(W)$	300
$V_{mp}(V)$	38.17
$V_{oc}(V)$	44.6
$I_{mp}(A)$	7.83

The sizing results give a PV array power  $P_{PVG}=45$  kW and a PV array voltage  $V_{PVG}=320$  V.

### 3.6 Storage system sizing

Battery storage capacity is calculated as follows:

$$C = \frac{N_j E_j}{DOD V_b} \tag{8}$$

$N_j$  : Number of days autonomy

$E_j$  : Daily energy consumption

DOD : Discharge depth

$V_b$  : Battery voltage

The battery characteristics are shown in the table 2.

**Table 2.** Battery characteristics.

Parameters	Value
Rated voltage(V)	12
Rated capacity(Ah)	180

### 3.7 Sizing DC-DC converters

#### 3.7.1 Boost converter

Sizing the Boost converter involves determining  $L$ ,  $C_1$  and  $C_2$  of the following circuit(fig.5):

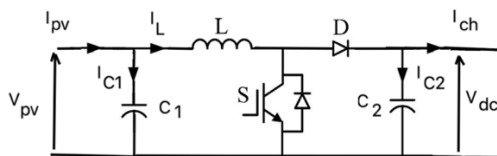

**Fig.5** Boost converter

The values of the ripple rate of the current and voltage are 2% and 5% respectively. The expressions and values of  $L$ ;  $C_1$  and  $C_2$  are given in the following equations:

$$L = \frac{V_{dc}}{4f_h \Delta I_L} = 11 \text{ mH} \tag{9}$$

$$C_1 = \frac{I_L}{4f_h \Delta V_{GPV}} = 0.1 \text{ }\mu\text{F} \tag{10}$$

$$C_2 = \frac{I_{PV}}{4f_h \Delta V_{dc}} = 1.3 \text{ }\mu\text{F} \tag{11}$$

$V_{dc}$  : DC bus voltage.

$f_h$  : Switching frequency

$\Delta I_L$  : Ripple rate of coil current.

$I_L$  : Coil current

$I_{pv}$  : Photovoltaic generator current

### 3.7.2 Buck-boost converter

The sizing of the Buck-Boost converter shown in Figure 6 involves determining the value of the minimum coil inductance  $L_{min}$  and the minimum capacitor capacitance  $C_{min}$ .

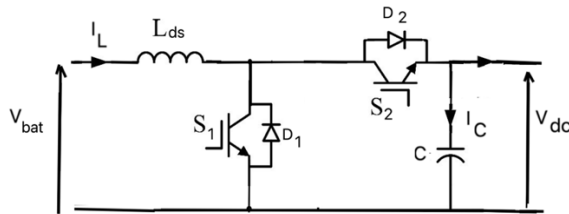

**Fig.6** Buck-Boost converter

The expressions for the minimum coil inductance and the minimum capacitance are given by the equations :

$$L_{min} = \frac{V_{dc}}{4f_h \Delta I_{bat}} = 2.2 \text{ mH} \tag{12}$$

$$C_{min} = \frac{I_{bat}}{4f_h \Delta V_{GPV}} = 26.7 \text{ }\mu\text{F} \tag{13}$$

## 4 Simulation results

The proposed photovoltaic fast-charging station is simulated using Matlab/Simulink software. The Simulink numerical model is shown in Fig.7.

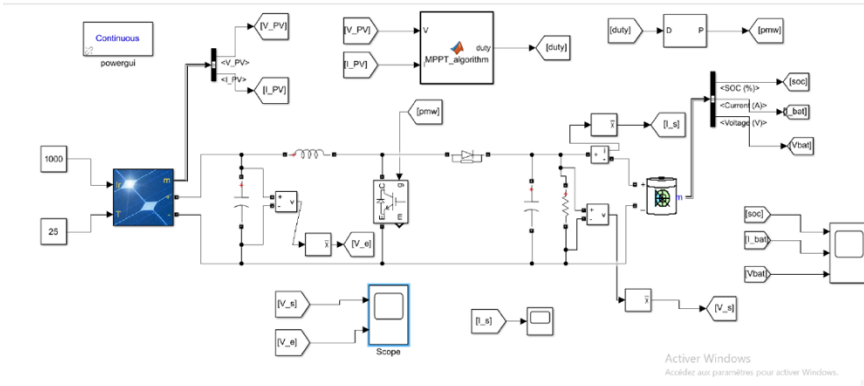

**Fig.7.** Numerical model of the fast-charging station in Simulink platform

A PO-type MPPT control was used. The MPPT control is used to find the optimal operating point of the PV array under variable weather conditions. The results of the simulation of the photovoltaic array with the PO-type MPPT control are shown in Figure 8. This control makes it possible to extract the optimal operating point of the photovoltaic array.

**Array type: Shanghai Topsolar Green Energy TSM72-156M 300V**  
**10 series modules; 15 parallel strings**

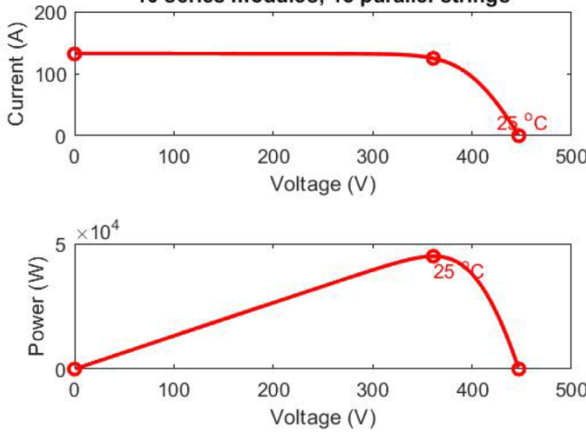

**Fig.8.** Variation of the current and power of the photovoltaic generator

The operation of the boost converter was simulated. The results are shown in Figure 9. The results show that the boost converter raises the PV array voltage to that of the DC bus.

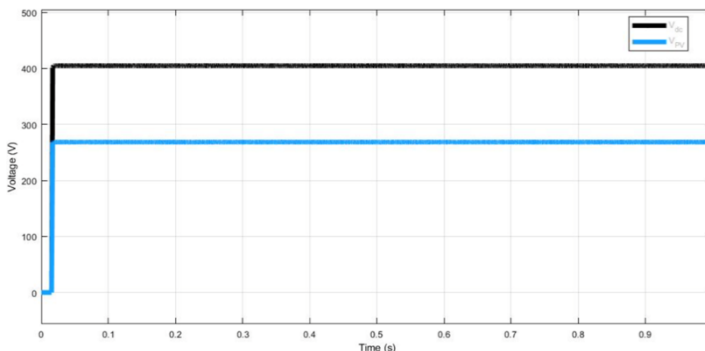

**Fig.9.** Photovoltaic generator voltage and Boost converter output voltage

In addition, a load management strategy has been developed for a typical day with solar irradiance measured as shown in Figure 10.

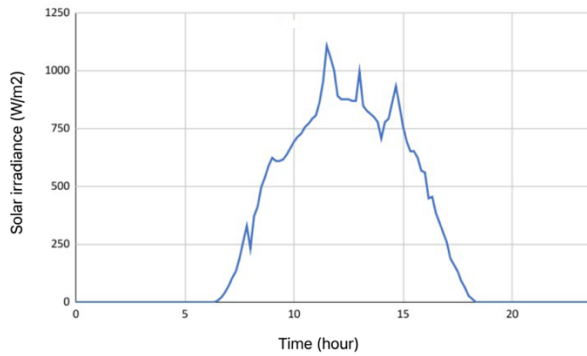

**Fig.10.** Global solar irradiation

The daily output of the PV array is shown in Figure 11

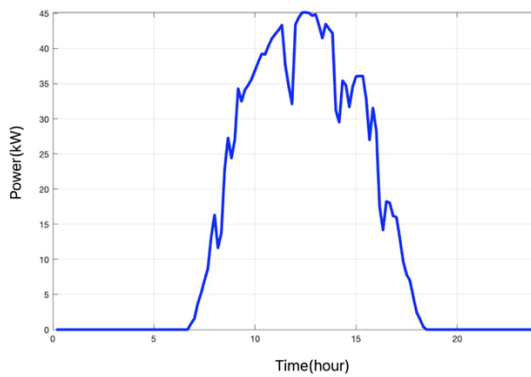

**Fig.11.** Daily production of PV array

A scenario for use of the station in the commune of Thienaba is developed. This scenario is used to construct the energy consumption profile of the tricycles. The charging station usage profile is shown in Figure 12.

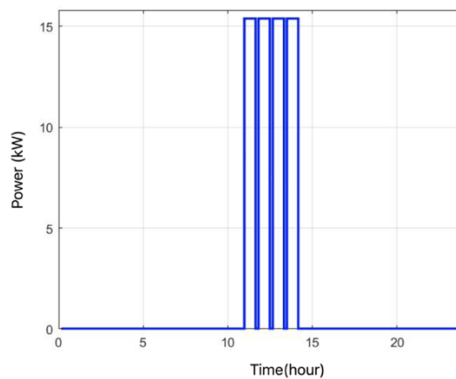

**Fig.12.** Load profile from 11 am to 2pm

The station consists of two charge points, each with a maximum power of 15.360 kW. The tricycles are charged between 11am and 2pm. This period corresponds to the photovoltaic generator's maximum output. A full charge takes 30 minutes. At 11am, the station's two terminals are connected to batteries 1 and 2 respectively of two tricycles. The initial charge level of the batteries is 20%. The final state of charge of 95% was reached at 11.30 am. At 11.40 am, batteries 3 and 4 from tricycles are connected to the station terminals. The final state of charge was reached at 12.10pm. At 12.20 pm, tricycle batteries 5 and 6 are connected to the station terminals. Charging continued until 12.50 pm. Tricycle batteries 7 and 8 are connected to the station terminals between 1pm and 1.30pm. Between 11 am and 2 pm, the station can charge eight (8) tricycles.

At the same time as the tricycle batteries were being charged, the state of charge of the station's storage system battery as analyzed. The simulation results are shown in Figure 13. The results of the charging of the storage system show that a charge rate of 70% can be achieved.

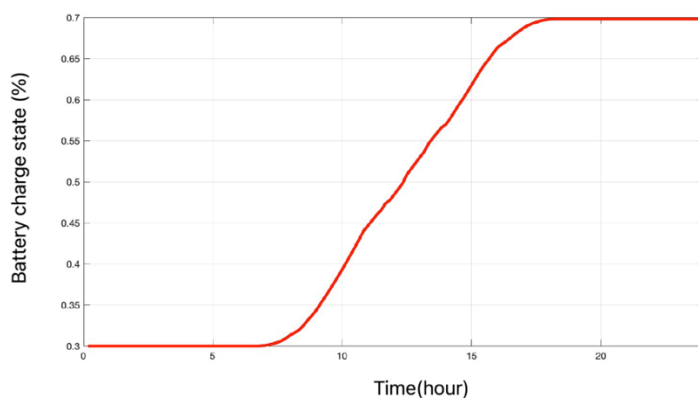

**Fig.13.** Station storage battery charging

## 5 Conclusion

This study focused on the design of a photovoltaic fast-charging station in the rural commune of Thienaba in order to demonstrate its feasibility. The area has significant solar potential that could be used to power tricycle fast-charging stations. The main conclusions of this work are as follows:

- tricycles are suitable for electric mobility in rural communities in sub-Saharan Africa
- the PV-based ultra-fast charging station is capable of recharging eight(08) tricycles between 11 a.m. and 2 p.m.
- The storage batteries are charged to a level of 70%.

As a follow-up to this work, we plan to

- optimize the design of the photovoltaic ultra-fast charging station
- develop a prototype in the commune of Thienaba
- coupling the photovoltaic field with another renewable energy source, such as a wind turbine.

## References

1. Global EV Outlook 2022, Securing supplies for an electric future. International Energy Agency publications, 221.p (2022).
2. Godwin Kafui Ayetor, Innocent Mbonigaba, Joseph Mashele, Feasibility of electric two and three-wheelers in Africa, *Green Energy and Intelligent Transportation* 2, 100106 (2023)
3. Access to electricity (%of population), World Bank, 2021 [cited 2023 21th February]; Available from: <https://data.worldbank.org/indicator/EG.ELC.ACCS.ZS?locations=ZG>
4. M J.A. Domínguez-Navarro, R. Dufo-López, J.M. Yusta-Loyo, J.S. Artal-Sevil, J.L. Bernal-Aguastín. Design of an electric vehicle fast-charging station with integration of renewable energy and storage systems. *Electrical Power and Energy Systems* 105, 46–58 (2019)
5. Mouli, C.G.R.; Schijffelen, J.; Heuvel, M.; Kardolus, M.; Bauer, P. A 10 kW Solar-Powered Bidirectional EV Charger Compatible with Chademo and COMBO. *IEEE Trans. Power Electron.*, 34, 1082–1098 (2019).
6. Abd El-Fattah A. Omran, Abd El-Shafy A. Nafeh, Hosam K. M. Yousef. Optimal Sizing of a PV-Battery Stand-Alone Fast Charging Station for Electric Vehicles Using SO. *International Journal of Renewable Energy Research*, Vol.12, No.4, December (2022).
7. Ibrahem E. Atawi, Essam Hendawi and Sherif A. Zaid. Analysis and Design of a Standalone Electric Vehicle Charging Station Supplied by Photovoltaic Energy. *Energy, Processes* 9, 1246(2021).
8. Aqib Shafiq, Sheeraz Iqbal, Salman Habib, Atiq ur Rehman, Anis ur Rehman, Ali Selim , Emad M. Ahmed and Salah Kamel. Solar PV-Based Electric Vehicle Charging Station for Security Bikes: A Techno-Economic and Environmental Analysis. *Sustainability* 14, 13767(2022).
9. Situation économique et sociale de la région de Thiès. Agence nationale de la statistique et de la démographie, Ministère de l'économie, du plan et de la coopération du Sénégal, (2019).
10. Pvgis [cited 2023 20th February]; Available from: [https://re.jrc.ec.europa.eu/pvg\\_tools/fr/](https://re.jrc.ec.europa.eu/pvg_tools/fr/)
11. A. A. Omran, F. H. Fahmy, A. A. Nafeh, and H. K. Yousef, "Sizing, Modeling and Control of Photovoltaic Traffic Light System," *IOSR J. Electr. Electron. Eng.*, vol. 11, no. 6, pp. 25-36, 2016. Traffic Light System," *IOSR J. Electr. Electron. Eng.*, vol. 11, no. 6, pp. 25-36 (2016).
12. T. M. E. Abou Saltouh, A. A. Nafeh, A. A. Abou El-Ela, F. H. Fahmy, and S. K. Nawar, "Control Strategy for Seamless Transition Between Grid-Connected and Islanding Modes in Microgrid-Based PV Inverters," *Energy Systems*, pp. 1-28, (2022).
13. M. Belhamelb M. Haddadic A. Louche S. Diafa, D. Diafb. "A methodology for optimal sizing of autonomous hybrid PV/wind system". *Energy Policy*, 35 :5708–5718 (2007).
14. Luigi Rubino, Clemente Capasso et Ottorino Veneri. Review on plug-in electric vehicle charging architectures integrated with distributed energy sources for sustainable mobility. *Applied Energy*, vol. 207, pages 438–464, December (2017).