

Adaptive Neuro-Fuzzy Energy Management of Grid-Connected PV Systems with Hybrid Storage for Voltage and Frequency Stability

Ambati Swetha^{1*}, N Bhoopal²

¹Dept. of EEE, B V Raju Institute of Technology, Narsapur, Telangana, India

²Professor, Dept. of EEE, B V Raju Institute of Technology, Narsapur, Telangana, India

Abstract. The paper presents an **Adaptive Neuro-Fuzzy Inference System (ANFIS)**- smart energy management scheme for a grid-connected hybrid power conversion system integrating photovoltaic (PV) generation, battery, and supercapacitor storage. The devised control maintains stability of the DC-side voltage stability, smooths PV power fluctuations, and ensures reliable operation under variable load and irradiance. Synergistic storage system utilizes a battery for long-term energy balancing and a supercapacitor for transient stabilization. The ANFIS controller adaptively manages power sharing between PV, grid, and storage elements, enhancing power quality and reducing Harmonic content ratio. Simulation results Evident that the proposed ANFIS-based Controller sustains THD at 0.24%, outperforming conventional PI and fuzzy controllers in dynamic response, settling time, and voltage regulation.

Keywords— ANFIS controller, Composite energy storage unit, grid-connected PV system, DC-link voltage control, total harmonic distortion (THD), power management scheme.

1 Introduction

Alternative energy sources solar PV, plays a crucial impact on sustainable development. However, its intermittent nature due to varying irradiance and temperature causes instability in grid-connected systems. To address this, hybrid energy systems (HES) combining PV, batteries, and supercapacitors have gained popularity.

Conventional controllers such as Classical PI and Fuzzy-based control frameworks are often used for power management but exhibit limitations under nonlinear and dynamic conditions. In contrast, ANFIS combines neural network learning and fuzzy inference for adaptive decision-making, making it highly suitable for managing nonlinear hybrid systems.

This work proposes an ANFIS-based power management scheme that coordinates PV generation, grid exchange, and hybrid energy storage to maintain voltage and frequency stability. The main novelty lies in integrating ANFIS-based control for DC-link voltage and THD reduction, compared to PI and fuzzy strategies.

2 Proposed System

The proposed grid-connected PV system with hybrid energy storage (battery and supercapacitor) is illustrated in Fig. 1. The PV array connects through a quadratic boost

*Corresponding author: 23211d0701@bvrit.ac.in

converter, while a bidirectional converter manages the battery and supercapacitor. A (VSI) Bridges the DC network bus Coupled to the grid through an LC filter.

The controller is intended to:

1. Stability of the DC-link voltage
2. Administer **energy sharing** among PV, grid, and storage, and
3. Minimize **THD** in grid current.

Power management ensures that during low PV generation, the battery discharges to maintain stability, and during surplus PV generation, both storage elements are charged. The supercapacitor handles transient energy, reducing stress on the battery.

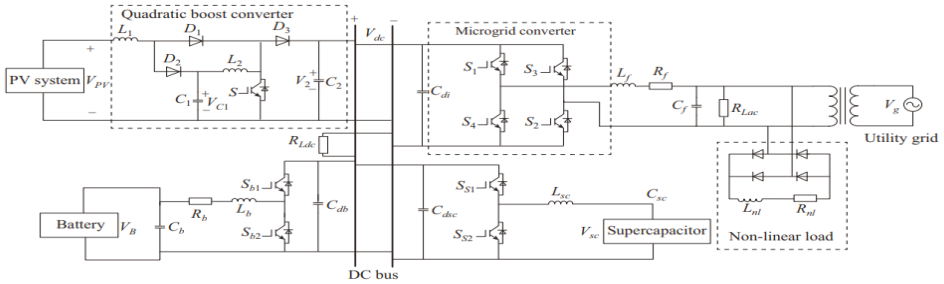

Fig. 1. Proposed system of grid-coupled PV with HESS.

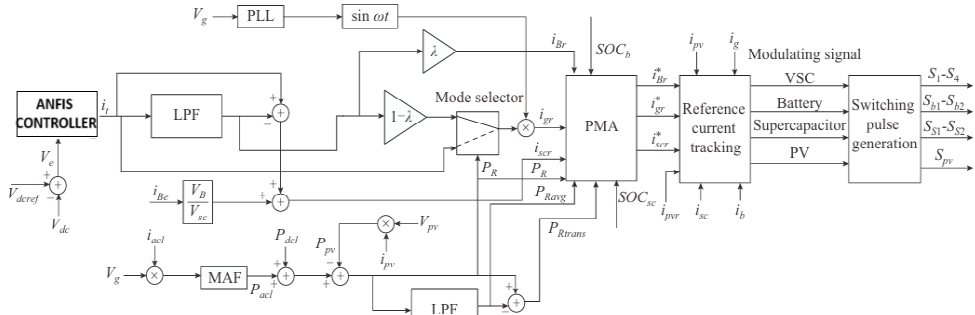

Fig.2. Strategic power allocation configuration for a grid-connected system.

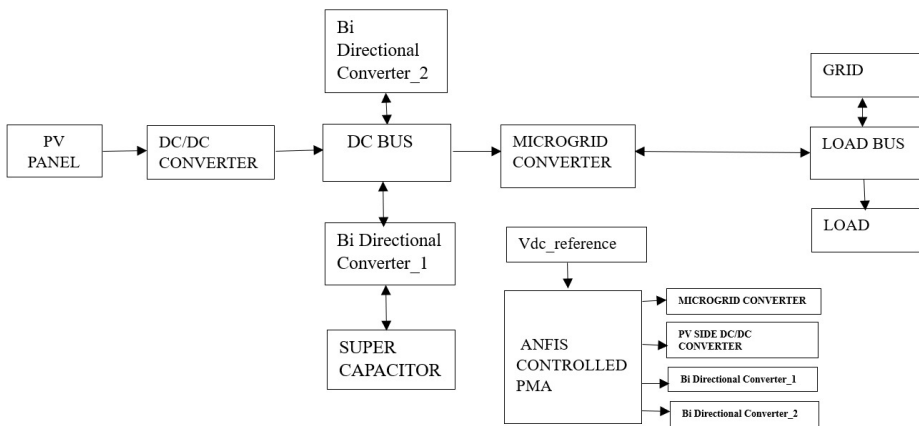

Fig.3. Block diagram.

The block diagram of the proposed (ANFIS)- Hybrid energy-centric management system shown in Fig. 3. The configuration integrates a PV panel, a battery, and a supercapacitor through individual bidirectional converters connected to a Unified DC-side network. The microgrid converter interfaces the bus of DC with the grid and load bus. The ANFIS-controlled power management algorithm (PMA) generates reference signals for each converter to preserve DC-link voltage stability, coordinate power flow, and enhance Complete system response under variable scenarios solar irradiance , load Circumstances.

3 The Suggested Approach to Power Management

The PMA Orchestrates the system's setup operating state Pursuant to the available generated and load power. According to the configuration (8), there are three distinct power modes P_R .

$$P_R = P_L - P_{PV} \quad (1)$$

- In IPM $P_R > 0$
- In SPM $P_R < 0$
- In FPM $P_R = 0$

The four distinct operating modes are defined Guided by the (SOC) of both the battery and the supercapacitor. as illustrated in Figure 3, In this figure, the initial SOC levels of the Multi-technology storage configuration are determined by Device-specific currents, i_b and i_{isc} . These currents also correspond to the nominal capacities of the battery and supercapacitor.

3.1 IPM

Here power mode, the PV system's The output fails to fulfill the required demand. Once the battery's (SOC) is Considering operational limits, the main grid, PV array, and battery together address the average shortfall in power. demand. In Table 2, you can see the IPM functional designs. The symbol * represents the battery reference current that is determined by the power management algorithm Battery-based and supercapacitor SOC limits. Table 3 outlines the power management in IPM, with P_{loss} representing system power losses, i_{loss} representing current losses, P_R representing Cumulative average power demand, P'_R representing The rapid fluctuation component of Capacity.

3.2 SPM

Within this framework operating mode, PV system produces additional energy than the immediate load demands. The surplus Electrical power facilitates the charging of the batteries , supercapacitors Up to their maximum (SOC) limits. Once Both storage elements achieve complete charging, any additional Power is transmitted to back Toward the main Routed to the grid via the (VSC). The functional design of the supercapacitor power management (SPM) and its corresponding power management strategy are detailed in Tables 4 and 5, respectively.

3.3 IPM

Depending on the load requirement, PV power generation either meets or falls short of it in this power mode. Upon full charge of all storage devices, the battery is disabled so that the supercapacitor may continue to provide the transitory power. Table 6 describes the FPM's power management, while Table 5 describes the FPM's functional designs. The three

variables here are the battery's rated power (P_{Br}), energy stored in the supercapacitor (E_{scr}) and the supercapacitor's rated power. The power management infrastructure of FPM.

4 ANFIS Based Control Strategy

The ANFIS controller consists of five layers combining fuzzy and neural network principles. It operates with two inputs: error and change in error (Δe) — and produces one output that regulates converter switching.

Stepwise Algorithm:

1. Measure PV power, grid voltage, and DC-link voltage.
2. Compute voltage error: $e = V_{dc}^* - V_{dc}$.
3. Evaluate change in error: $\Delta e = e(k) - e(k - 1)$.
4. Feed (e , Δe) to ANFIS structure.
5. ANFIS processes data using fuzzy IF–THEN rules.
6. Generate control signal for inverter.
7. Adjust converter duty cycle to maintain stable DC-link voltage.

This intelligent controller adapts in real-time to disturbances, improving system robustness under load and irradiance variations.

5 Extension Results

5.1 Performance With Variable PV Power

The template is designed for, but not limited to, six When the quantity of power produced by PV changes, the intended control methods actively work, as shown in Figures 4 and 5. The PV power production decreases dramatically throughout the 2 s period, as seen in Fig. 4. In spite of variations in PV output, the DC bus voltage Fig.4 demonstrates that it stabilizes within 0.15 s with a 1 V undershoot. If we go by the IEEE standard 929-2000, this is perfectly acceptable. The short surge in power during the switch is handled by the supercapacitor device. The grid and battery units coordinate to change the average component, which keeps the DC connection voltage constant. Reducing the settling period quickly brings the final DC-bus voltage value closer to the required error. Powers and voltages of the DC connection, supercapacitor and battery are shown in Fig.4, and Fig. 5 displays the same information.

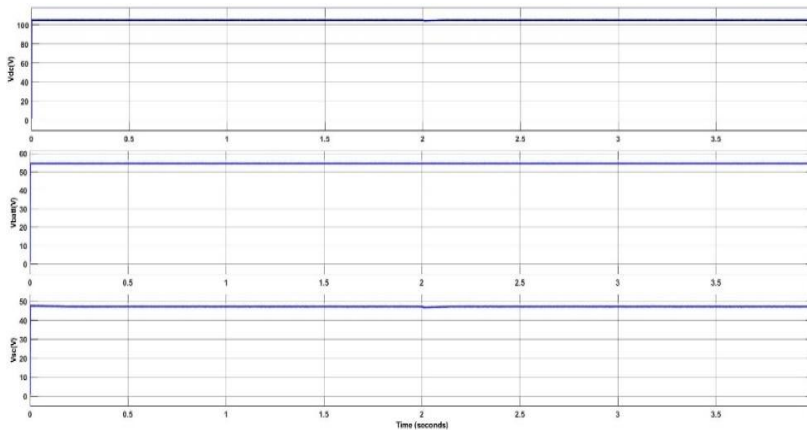

Fig. 4. Electrical potential of DC-link, battery, and supercapacitor under PV output variations

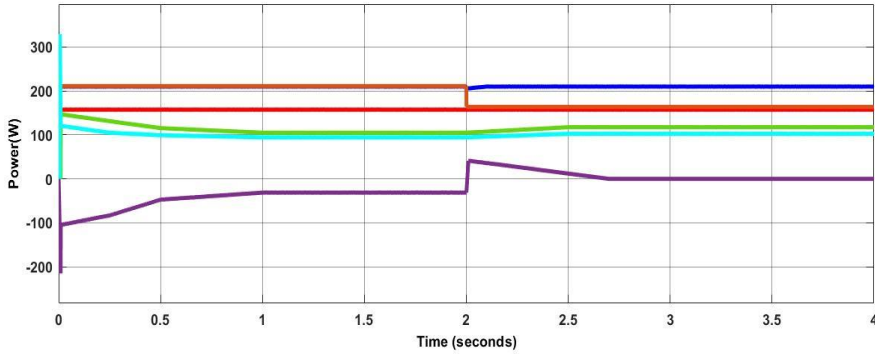

Fig. 5. Power profiles across PV, DC and AC loads, grid, battery, and supercapacitor under PV generation variability.

Fig.6 shows how the Grid-coupled current (THD) interacts with variation in PV power. Figure 7 demonstrates that the utility grid current has a total harmonic distortion (THD) of 0.24%. System harmonics may decrease the lifetime of appliances and lead to higher load losses due to electronics overheating, malfunctioning, and experiencing greater voltage stress and heating in capacitors. Therefore, it is important to adhere to the permitted harmonic range.

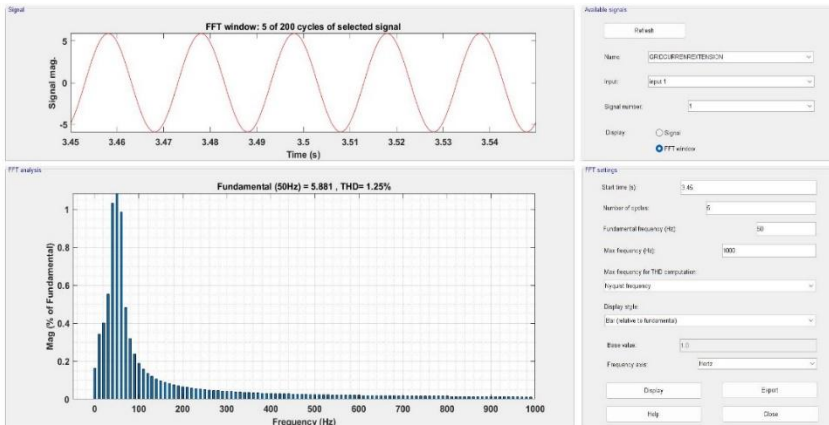

Fig. 6. Variations in grid current harmonic distortion caused by changing PV power.

6 PERFORMANCE WITH IPM

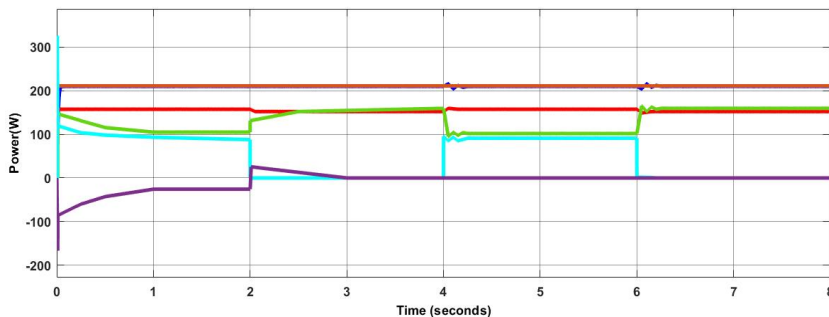

Fig. 7. PV, DC load, AC load, grid, battery, and supercapacitor power under IPM.

Because system's requirements are non-linear, the VSC supplies the harmonic components that are needed. Figure 8 shows that the current I_g on the grid side remains constant and attains a power factor of one during the whole simulation.

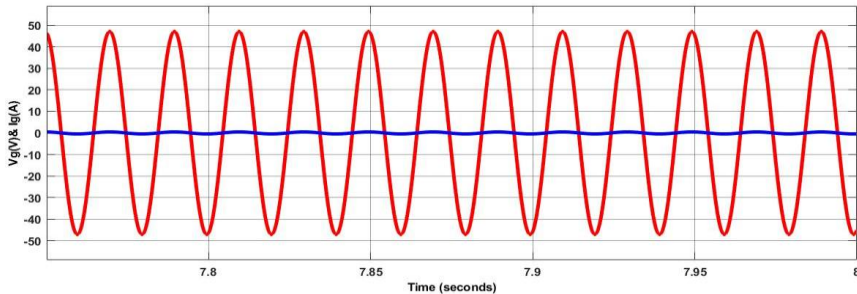

Fig. 8. High-resolution representation of grid voltage and current with IPM

7 Comparison of Controller Performance

Table 3. Comparison of controller performance.

| Parameter | PI Controller | Fuzzy Controller | ANFIS Controller |
|---------------------------|---------------|------------------|------------------|
| DC-Link Settling Time (s) | 0.35 | 0.25 | 0.15 |
| THD (%) | 2.8 | 1.1 | 0.24 |
| Voltage Stability | Moderate | Good | Excellent |

8 Conclusion

An ANFIS-based power The EMS strategy has been deployed developed for a grid-connected hybrid Arrangement integrating PV, Secondary cell, and High-rate chargeThe controller effectively maintains DC-link voltage stability, reduces THD, and enhances system efficiency compared to PI and Fuzzy controllers. Future work includes implementing the proposed control scheme on a hardware-in-the-loop or microgrid prototype to validate real-time performance.

References

- 1.S.K. Kollimalla, M.K. Mishra, "A novel adaptive P&O MPPT algorithm considering sudden changes in the irradiance," *IEEE Trans. Energy Convers.*, **29**, 602–610 (2014). <https://doi.org/10.1109/TEC.2014.2314153>
2. S. Mishra, R.K. Sharma, "Dynamic power management of PV-based islanded microgrid using hybrid energy storage," in *Proc. IEEE 6th Int. Conf. Power Systems (ICPS)*, New Delhi, India (2016), 1–6. <https://doi.org/10.1109/ICPES.2016.7584160>
3. C. Natesan, S. Ajithan, S. Chozhavendhan, "Power management strategies in microgrid: a survey," *Int. J. Renew. Energy Res.*, **5**, 334–340 (2015).

4. Z. Yi, W. Dong, A.H. Etemadi, “A unified control and power management scheme for PV-battery-based hybrid microgrids for both grid-connected and islanded modes,” *IEEE Trans. Smart Grid*, **9**, 5975–5985 (2018). <https://doi.org/10.1109/TSG.2017.2711031>
5. S. Pannala, N. Patari, A.K. Srivastave, “Effective control and management scheme for isolated and grid connected DC microgrid,” *IEEE Trans. Ind. Appl.*, **56**, 1–14 (2020). <https://doi.org/10.1109/TIA.2020.3006547>
6. P. Singh, J.S. Lather, “Variable structure control for dynamic power-sharing and voltage regulation of DC microgrid with a hybrid energy storage system,” *Int. Trans. Electr. Energy Syst.*, **30**, 1–20 (2020). <https://doi.org/10.1002/2050-7038.12526>
7. N.R. Tummuru, U. Manandhar, A. Ukil, “Control strategy for AC–DC microgrid with hybrid energy storage under different operating modes,” *Int. J. Electr. Power Energy Syst.*, **104**, 807–816 (2019). <https://doi.org/10.1016/j.ijepes.2018.07.028>
8. J. Hu, Y. Shan, Y. Xu, “A coordinated control of hybrid AC/DC microgrids with PV–wind–battery under variable generation and load conditions,” *Int. J. Electr. Power Energy Syst.*, **104**, 583–592 (2019). <https://doi.org/10.1016/j.ijepes.2018.07.012>
9. H. Mahmood, D. Michaelson, J. Jiang, “A power management strategy for PV/battery hybrid systems in islanded microgrids,” *IEEE J. Emerg. Sel. Top. Power Electron.*, **2**, 870–882 (2014). <https://doi.org/10.1109/JESTPE.2014.2325832>
10. P. Sanjeev, N.P. Padhy, P. Agarwal, “Peak energy management using renewable integrated DC microgrid,” *IEEE Trans. Smart Grid*, **9**, 4906–4917 (2018). <https://doi.org/10.1109/TSG.2017.2674684>