

AI-based antenna design and optimization using MOZO algorithm

Bilal Jellam^{1*}, Saida Ahyoud¹, and Mustapha El Halaoui¹

¹TIMS, Faculty of Sciences, Abdelmalek Essaadi university. Tétouan, Morocco

Abstract. Wireless communication has revolutionized technology in recent years performance and capacity are affected when new smart devices arrive. the 5G technology comes with high performance antenna solutions that can deliver faster data rates, lower latency, and enhanced reliability. Printed antennas due to their low cost, compact size and ease of fabrication are becoming an essential component in 5G wireless communication systems like (massive MIMO, mm Wave...) [1]. This papers will explores the optimization of printed antennas for 5G application , focusing on the use advanced MOZO [2]technique to enhance performance metrics like bandwidth, gain, efficiency and beamforming capabilities , we will present a comprehensive study of antenna design techniques , which can significantly improve the overall performance, a multi objective optimization approach is implemented to fine tune key parameters while meeting the stringent demands of 5G network, including mm Wave frequency Bands. The simulation validation demonstrates the effectiveness of this optimization technique in achieving optimal antenna performance for 5G communication systems. CST and MATLAB were used to perform and evaluate the antenna performance in terms of return loss and gain.

1 Introduction

Rapid growth in 5G wireless communication calls for antennas with high performance to cater ultra-high data rate, low-latency, and high-reliability demand. Printed antennas are one of the several types of antennas that came into focus as a determining factor in the realization of 5G systems because of their low expense, miniaturized size, ease of manufacture, and integration into future wireless devices. Their geometric simplicity allows them to be mass-produced and integrated into high-end applications like MIMO and mmWave technologies. However, the design and optimization of printed antennas for 5G applications, particularly in the mmWave frequency range, remain challenging.

Under such elevated frequencies, antenna performance must meet stringent requirement such as large gain, broad bandwidth, efficient beamforming, and minimal signal loss. These are challenging to achieve with traditional design methods. Traditionally, antenna optimization has been executed with manual tuning and iterative simulations, which are time and computationally expensive. But with the arrival of artificial intelligence (AI), new intelligent methods have emerged that simplify the optimization process reduce design time, and improve accuracy one such thrilling method is Multi-Objective zebra optimization (MOZO), which can optimize more than a single parameter of an antenna at once, as gain, bandwidth, efficiency and beam direction and determine the best trade off among them.

By using AI optimization, engineers can simply explore enormous design spaces and find the best solutions without the need for trial and error. With this, antennas can be optimized to meet specific 5G system performance This article is aimed at the application of AI-driven MOZO technic for the optimization of printed 5G communications antennas. It takes into consideration how the technic assist in optimizing key performance parameters and also shows the contribution of advanced materials as metamaterials and graphene toward the enhancement of antenna features. Simulation outcomes by MATLAB confirm the superiority of AI-MOZO, showing its capability to offer high-performance antenna solutions suitable for application in future networks. Particularly, microstrip patch antenna (MPAs) are extensively studied for 5G mmWave applications since they are low profile, lightweight and readily integratable in small systems. However, at mmWave frequencies, it is of paramount importance to optimize their gain, impedance matching, and bandwidth to ensure effective radiation and avoid losses, so AI optimization technics are that much more crucial to achieve that.

2 Design and simulation of patch antenna

The proposed design is compact rectangular microstrip patch antenna operating at 28 GHz 5G applications. It uses a center-inset feed with a U-shaped notch at the

* Corresponding author: bilal.jellam@etu.uae.ac.ma

lower edge of the patch to improve impedance matching and bandwidth performance.

2.1 Patch antenna Geometry

The performance of Microstrip patch antenna largely depends on the substrate material, the antenna is fabricated on a Rogers RT5880 substrate with a relative permittivity of 2.2, a loss tangent of 0.0009, and thickness of 0.508 mm, which improves antenna performance.

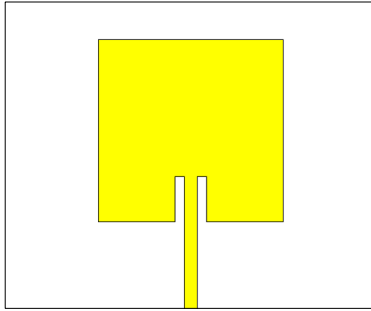

Fig. 1. Microstrip Patch Antenna.

Fig shows the basic rectangular microstrip patch antenna designed to operate at 28 GHz. Th antenna is built on a Rogers RT5880 substrate. Known for this low dielectric loss and stability at high frequencies. This basic patch layout serves as the reference model.it illustrates the simplicity of the structure and sets the baseline for comparison with optimized versions. However, this traditional design may have limited performance in bandwidth and gain at mmWave frequencies, which optimization technics aim to enhance.

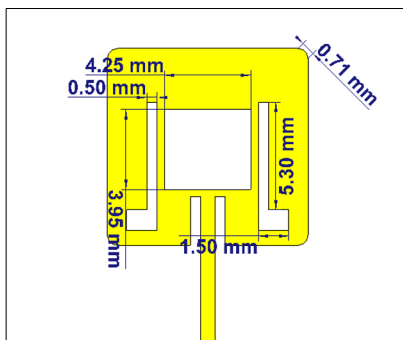

Fig. 2. Microstrip patch Antenna optimized by slots

It shows the same microstrip patch antenna but with introduced slots in the radiating patch. These slots are designed to optimized antenna performance. The slotting technic significantly improves antenna performance by altering current patch, which enhances impedance matching and broadens bandwidth. The optimized version demonstrates the advantage of AI-Based optimization in meeting the high-frequency requirements of 5G systems.

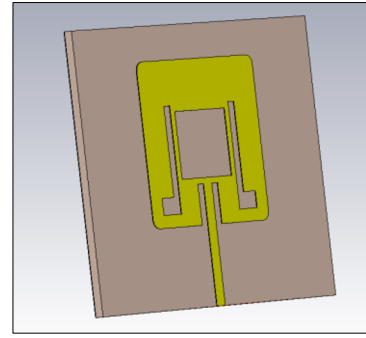

Fig. 3. Overview of Patch antenna

This figure provides a 3D view or layout of the complete patch antenna structure including substrate, patch, ground, and feedline. It shows the full assembly and helps understand the physical relationship among components. This figure provides a clear overview of the antenna structure and supports the design specification summarized in Result table. It confirms the compact nature of the design and the integration of high-performance materials aimed at mm Wave operation.

2.2 Design Equations

The patch designed to operate at 28 GHz which is the the patch width is determined by the standard design relation:

$$W = \frac{c}{2f_r} \sqrt{\frac{2}{\epsilon_r + 1}} \quad (1)$$

and the effective dielectric constant is:

$$\epsilon_{eff} = \frac{\epsilon_r + 1}{2} + \frac{\epsilon_r - 1}{2} \left(\frac{1}{\sqrt{1 + 12h/W}} \right) \quad (2)$$

And effective length of the patch is:

$$L_{eff} = \frac{c}{2f_r \sqrt{\epsilon_{eff}}} \quad (3)$$

To compensate for the fringing effect, the length extension is computed as:

$$\Delta L = 0.412h \cdot \frac{(\epsilon_{eff} + 0.3) \left(\frac{W}{h} + 0.264 \right)}{(\epsilon_{eff} - 0.258) \left(\frac{W}{h} + 0.8 \right)} \quad (4)$$

So, the patch length is obtained from:

$$L = L_{eff} - 2\Delta L \quad (5)$$

The antenna is implemented using a 50-Ω microstrip line. The feed width W_f is obtained from the microstrip transmission line equations. For the case $W_f/h > 1$, the characteristic impedance is approximated as:

$$Z_0 = \frac{120\pi}{\sqrt{\epsilon_{eff}} \left(\frac{W_f}{h} + 1.393 + 0.667 \ln \left(\frac{W_f}{h} + 1.444 \right) \right)} \quad (5)$$

Which is W_f for the chosen substrate. Impedance matching between the patch and the feedline is achieved by an inset fed structure.

2.3 Result Summary

Parameters	Symbol	Value(mm)
width of Patch	W_p	9.9
length of Patch	L_p	9.7
Thickness of Patch	H_p	0.035
width of Ground	W_{gnd}	20
length of ground	L_{gnd}	16.5
Thickness of Ground	H_{gnd}	0.035
width of Substrate	W_s	20
length of Substrate	L_s	16.5
Thickness of Substrate	H_s	0.508
width of feedline	W_f	0.7
length of feedline	L_f	4.75

3 MOZO Optimization Algorithm

3.1 Principle and objective functions

MOZO is powerful AI-driven optimization technic that can significantly improve the design of patch antennas. By optimizing multiple parameters simultaneously, it helps achieve better gain, lower return loss, and wider bandwidth critical 5G applications at 28 GHz.

It is an artificial intelligence optimization algorithm based on zebra herd behaviour. It emulates:

- Herd movements patterns to traverse the search space.
- Leader follower behaviour to improve solutions.
- Exploratory adaptation for trade-off between local global search.

MOZO can handle a group of conflicting targets, which makes it applicable to antenna design, wireless communication, and RF circuit tuning.

3.2 MOZO Flowchart

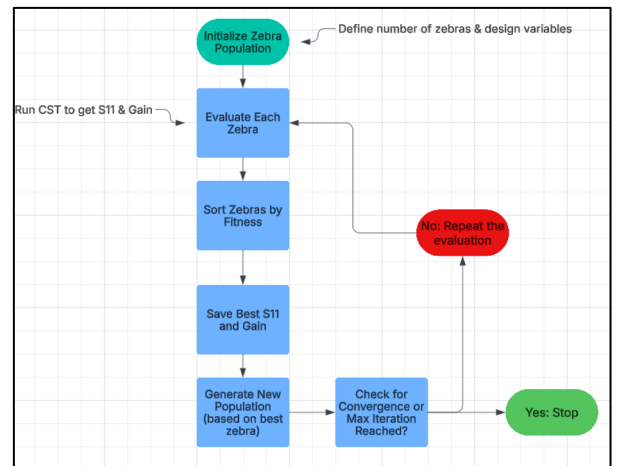

Fig. 4. MOZO Algorithm Organigramme

This figure provides a flowchart of MOZO technique, as below the steps description:

1. Initialize: a random population of zebras (each zebra = one antenna design)
2. Evaluation: each zebra
 - Send the parameters to CST
 - Simulate the antenna
 - Extract S11 and gain
3. Sort: the zebras from best to worst based on the fitness function
4. Record: the best S11 & Fain values at each iteration
5. Generate a new population:
 - Half influenced by the best zebra
 - Half influenced by random good zebras
6. Repeat until:
 - Maximum number of iterations reached
 - Or improvement becomes negligible

3.3 Integration with CST

The integration of MOZO and CST is implemented a closed optimization loop. For each iteration, MOZO generates a set of parameters for the antenna geometry, which are passed to CST. The last one runs a complete electromagnetic simulation with these parameters and provides performance output, here typically S11 and Gain. The output is passed back to MOZO and used as fitness functions to evaluate how good the design under consideration is. according to this evaluation MOZO modifies the parameters and sends a new set to CST. Iteratively, the process goes on with repeated update between CST and MOZO until the algorithm converges and the optimal antenna design is obtained.

4 Results and Discussion

4.1 S11 / Return Loss and Bandwidth

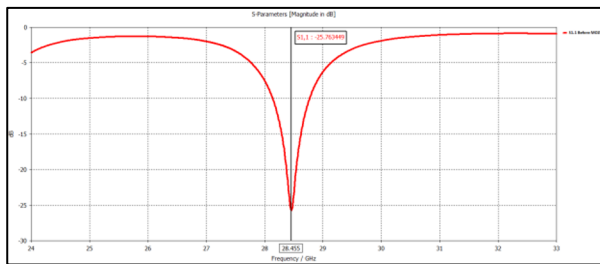

Fig. 5. S1.1 Before MOZO

This graph shows the S11 parameters (return Loss) of the antenna before applying the MOZO optimization technique.

- The curve represents how much power is reflected back from the antenna across the frequency band
- The resonance occurs around 28.5 GHz, where the return Loss reaches approximately -25 dB, indicating good impedance matching at that frequency.
- The -10 dB bandwidth spans from about 28.14 GHz to 28.77 GHz, giving a bandwidth of roughly 0.63 GHz.
- Outside this range, the return loss is higher (closer to 0 dB), that means less efficient matching.

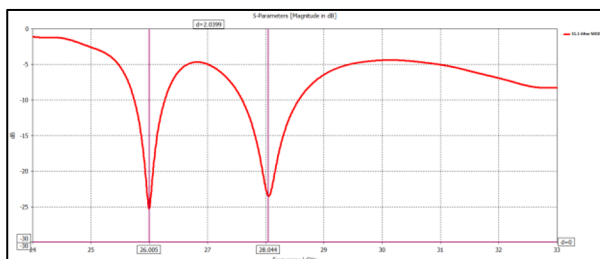

Fig. 6. S1.1 After MOZO

This graph shows the S11 parameter after applying the MOZO optimization technique:

- After optimization, the antenna exhibits multiple resonant frequencies around 26.0 GHz, 26.27 GHz, and 28.04 GHz, with a wider effective bandwidth.
- Importantly, the -10 dB bandwidth has significantly increased to about 2.05 GHz, covering from roughly 26 GHz to 28.57 GHz, compared to approximately 0.63 GHz before MOZO.
- This indicates much broader matching performance, making the antenna more suitable for wideband 5G applications.

4.2 Radiation Pattern

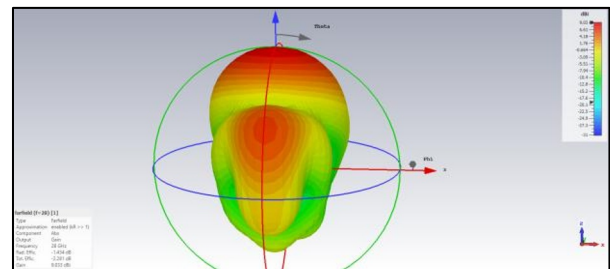

Fig. 6. Farfield before MOZO

This 3D plot shows the antenna's radiation pattern before MOZO optimization. The antenna exhibits a directional radiation profile with a peak of 9.03 dBi at 28 GHz. The main lobe is centered along the positive Z-axis, indicating the direction of maximum radiation. The total efficiency is -2.28 dB, and the radiation efficiency is -1.34 dB, suggesting moderate losses before optimization.

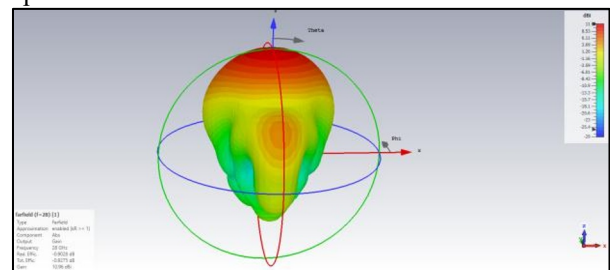

Fig. 7. Farfield After MOZO

After MOZO optimization, the antenna shows an improved directional radiation pattern with a higher peak gain of 10.96 dBi at 28 GHz. The main lobe remains centered along the Z-axis, similar to the pre-optimization case. The total and radiation efficiencies have also improved slightly to -0.93 dB and -0.90 dB, respectively, indicating lower losses and better overall performance.

4.3 Gain before and after MOZO result

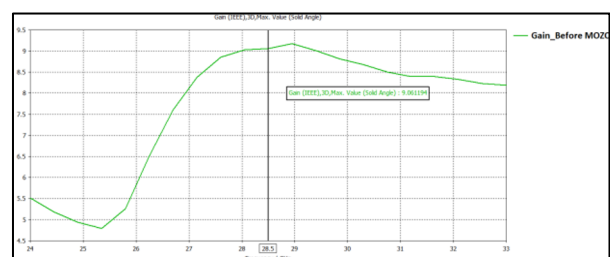

Fig. 8. Gain Before MOZO

The graph provides the antenna gain before applying the MOZO technique. The gain gradually increases with frequency, reaching a peak value of 9.06 dBi at 28.5 GHz. This indicates strong performance at the resonant frequency. But the gain drops at lower and higher frequencies, showing a narrower bandwidth and less stable performance across the range.

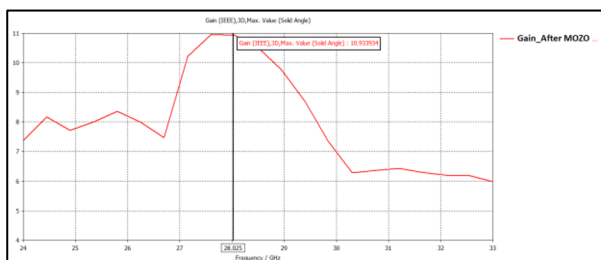

Fig. 9. Gain After MOZO

After MOZO applied the antenna gain increased to 10.93 dBi at 28.03 GHz which is higher than before optimization. The gain remains relatively high across a wider frequency range compared to the pre-optimization case. Showing improved bandwidth and overall performance.

4.4 Comparison Result

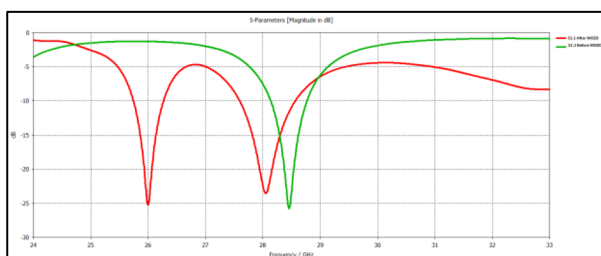

Fig. 10. S1.1 Before Vs After MOZO

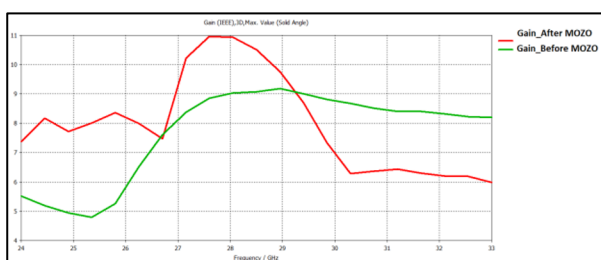

Fig. 11. Gain Before Vs After MOZO

As result comparison, the following MOZO treatment the antenna shows significant improvements the both in gain and impedance matching. The peak gain was raised from 9.06 dBi -Before MOZO- to 10.93 dBi -after MOZO-, showing enhanced radiation performance. the S11 response shows two distinct resonant frequencies, one near 26 GHz and another around 28.57 GHz. Overall, the MOZO technique enhanced the performance and efficiency of the antenna.

5 Conclusion

Throughout this paper, the simple design, optimization and verification of a compact rectangular patch microstrip antenna at 28 GHz for 5G were presented. The initially designed antenna, which was on a Rogers RT5880 substrate, was exhibiting good performance in gain and impedance matching initially. However, with the incorporation of the Multi-Objective Zebra optimization (MOZO) algorithm, the performance of the antenna was improved.

Simulation results confirmed MOZO performance with extreme improvement in impedance bandwidth and

gain. Specifically, the peak gain was heightened from 9.06 to 10.93 dBi. Radiation efficiency and overall efficiency were also improved to ensure the power of MOZO is an effective optimization toll for optimizing broad band, high frequency 5G antenna designs.

References

1. B V, V V, V A. Anovel artificial intelligence-based antenna designing model for optimizing 5G mobile communication. *Internet Technology Letters*. 2024;e586. doi: [10.1002/itl2.586](https://doi.org/10.1002/itl2.586).
2. Hong W, Jiang ZH, Yu C, et al. The role of millimeter-wave technologies in 5G/6G wireless communications. *IEEE J Microw*. 2021;1(1):101-122. Doi: [10.1109/JMW.2020.3035541](https://doi.org/10.1109/JMW.2020.3035541)
3. A. D. Tadesse, O. P. Acharya, and S. Sahu, "A Compact Planar Four-port MIMO Antenna for 28/38 GHz Millimeter-wave 5G Applications," *IEEE Transactions on Antennas and Propagation*, vol. 11, no. 3, August 2022. DOI: [10.1109/TAP.2022.3199243](https://doi.org/10.1109/TAP.2022.3199243)
4. Xingyi He, "A Printed Dipole Antenna for 5G Millimeter Wave Application," *Journal of Physics: Conference Series*, vol. 1802, 2021. DOI: [10.1088/1742-6596/1802/2/022083](https://doi.org/10.1088/1742-6596/1802/2/022083)
5. Al-Khaffaf DAJ, Alshimaysawe IA. Miniaturised tri-band microstrip patch antenna design for radio and millimeter waves of 5G devices. *Indones J Electr Eng Comput Sci*. 2021;21:1594-1601. doi:10.11591/ijeecs.v21.i3.pp1594-1601
6. Ezzulddin SK, Hasan SO, Ameen MM. Microstrip patch antenna design, simulation and fabrication for 5G applications. *Simul Model Pract Theory*. 2022;116:102497.
7. Hossain, M. M., Alam, M. J., & Latif, S. I. (2022). Orthogonal Printed Microstrip Antenna Arrays for 5G Millimeter-Wave Applications. *Micromachines*, 13(1), 53. <https://doi.org/10.3390/mi13010053>
8. Kamal, M. M., Yang, S., Kiani, S. H., Anjum, M. R., Alibakhshikenari, M., Arain, Z. A., Jamali, A. A., Lalbakhsh, A., & Limiti, E. (2021). Donut-Shaped mmWave Printed Antenna Array for 5G Technology. *Electronics*, 10(12), 1415. <https://doi.org/10.3390/electronics10121415>
9. Saraereh OA. A novel broadband antenna design for 5G applications. *Comput Mater Contin*. 2021;67(1):1121-1136. doi:10.32604/cmc.2021.015066